

F I A T D U C A T O



O W N E R H A N D B O O K

This Owner Handbook is intended to show the vehicle's operating conditions.

For the enthusiast user who wants to have insights, curiosities and detailed information about the characteristics and functions of the vehicle, Fiat Professional gives the opportunity to consult a dedicated section which is available in electronic format.

### **ONLINE VEHICLE OWNER HANDBOOK**

The following symbol  is reported within the text of the Owner Handbook, next to the subjects for which details are provided.

Go to the [www.mopar.eu/owner](http://www.mopar.eu/owner) website and access your personal area.

The “Maintenance and care” page includes all the information about your vehicle and the link to access *eLUM*, where you will find all the details of the Owner Handbook.

Alternatively, to access this information, go to the Internet website at <http://aftersales.fiat.com/elum/>.

The *eLUM* website is free and will allow you, among many other things, to easily consult the on-board documents of all the other vehicles of the Group.

Have a nice reading and happy motoring!

## Dear Customer,

We would like to congratulate and thank you for choosing a Fiat Ducato. We have written this handbook to help you get to know all the features of your vehicle and use it in the best possible way. You should read it right through before taking to the road for the first time.

You will find information, tips and important warnings regarding the use of your vehicle to help you get the most from the technological features of your Fiat Ducato. It also provides a description of special features and essential information for the care and maintenance of your vehicle over time as well as for safe driving.

We urge you to read the warnings and indications found throughout the text with care, marked with the following symbols:



personal safety;



vehicle integrity;



environmental protection.

NOTE These symbols, when necessary, are reported at the end of each paragraph and are followed by a number. That number recalls the corresponding warning at the end of the relevant section.

In the enclosed Warranty Booklet you will also find a description of the Dealer Services that the manufacturer offers to its customers, the Warranty Certificate and details of the terms and conditions for the maintenance of the vehicle.

We are confident that these tools will bring you closer to your new vehicle and make you appreciate the assistance provided by the Stellantis team.

Enjoy reading. Happy driving!

**This Owner Handbook describes all Fiat Ducato versions. As a consequence, you should only consider the information which is related to the trim level, engine and version that you have purchased. All data contained in this publication are purely indicative. Stellantis Europe S.p.A. can modify the specifications of the vehicle model described in this publication at any time, for technical or marketing purposes. For further information, contact a Fiat Dealership.**

# READ THIS CAREFULLY



## REFUELLING



Only refuel with automotive diesel conforming to the European specification EN590. The use of other products or mixtures may damage the engine beyond repair and consequently invalidate the warranty, due to the damage caused.

## STARTING THE ENGINE



Make sure that the parking brake is engaged; set the gear lever to neutral; fully depress the clutch pedal without pressing the accelerator, then turn the ignition key to MAR and wait for the warning lights  and  to switch off; turn the ignition key to AVV and release it as soon as the engine has started.

## PARKING ON FLAMMABLE MATERIAL



The catalytic converter develops high temperatures during operation. Do not park on grass, dry leaves, pine needles or other flammable material: fire hazard.

## RESPECTING THE ENVIRONMENT



The vehicle is fitted with a system that allows continuous diagnosis of the emission-related components in order to help protect the environment.

## ELECTRICAL ACCESSORIES



If, after buying the vehicle, you decide to add electrical accessories (with the risk of gradually draining the battery), visit a Fiat Dealership. They can calculate the overall electrical requirement and check that the electrical system of the vehicle can support the required load.



## SCHEDULED SERVICING



Correct maintenance enables the vehicle to perfectly maintain performance and safety characteristics, its environmental friendliness and low running costs over time.

## THE OWNER HANDBOOK CONTAINS...



... important information, advice and warnings for correct use, driving safety and maintenance of your vehicle over time. Particular attention should be paid to information marked with the following symbols:  (personal safety),  (environmental protection),  (vehicle integrity).



**GRAPHICAL INDEX**



**KNOWING YOUR VEHICLE**



**KNOWING THE INSTRUMENT PANEL**



**SAFETY**



**STARTING AND DRIVING**



**IN CASE OF EMERGENCY**



**SERVICING AND MAINTENANCE**



**TECHNICAL SPECIFICATIONS**



**MULTIMEDIA**



**CONTENTS**





# GRAPHICAL INDEX

## 3/4 front

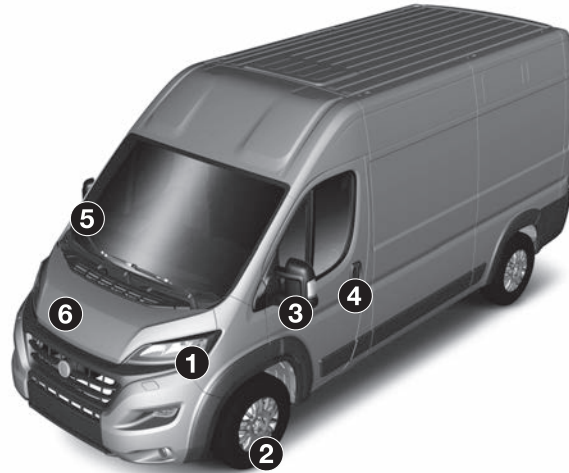

### 1 HEADLIGHTS

- Bulb types . . . . . 229
- Daytime running lights . . . . . 39
- Side lights/dipped headlights . . . . . 39
- High beam headlights . . . . . 39
- Bulb replacement . . . . . 232

### 2 WHEELS

- Rims and wheels . . . . . 285
- Tyre pressure . . . . . 285

- Changing a wheel . . . . . 238
- Tyre repair kit . . . . . 243

### 3 DOOR MIRRORS

- Adjustment . . . . . 36
- Folding . . . . . 36

### 4 DOORS

- Central opening/closing . . . . . 19

### 5 WINDSCREEN WIPER

- Operation . . . . . 44
- Blade replacement . . . . . 264

### 6 ENGINE

- Checking levels . . . . . 258
- Technical specifications . . . . . 277

F1A5000



**3/4 rear**



2

F1A5001

|                              |     |
|------------------------------|-----|
| <b>① REAR LIGHTS</b>         |     |
| □ Bulb types . . . . .       | 229 |
| □ Bulb replacement . . . . . | 232 |
| <b>② LOAD COMPARTMENT</b>    |     |
| □ Opening/closing . . . . .  | 19  |
| <b>③ THIRD BRAKE LIGHT</b>   |     |
| □ Bulb types . . . . .       | 229 |
| □ Bulb replacement . . . . . | 232 |
| <b>④ PARKING SENSORS</b>     |     |
| □ Operation . . . . .        | 178 |

# Dashboard (versions with 7" and 10" Uconnect™ system)

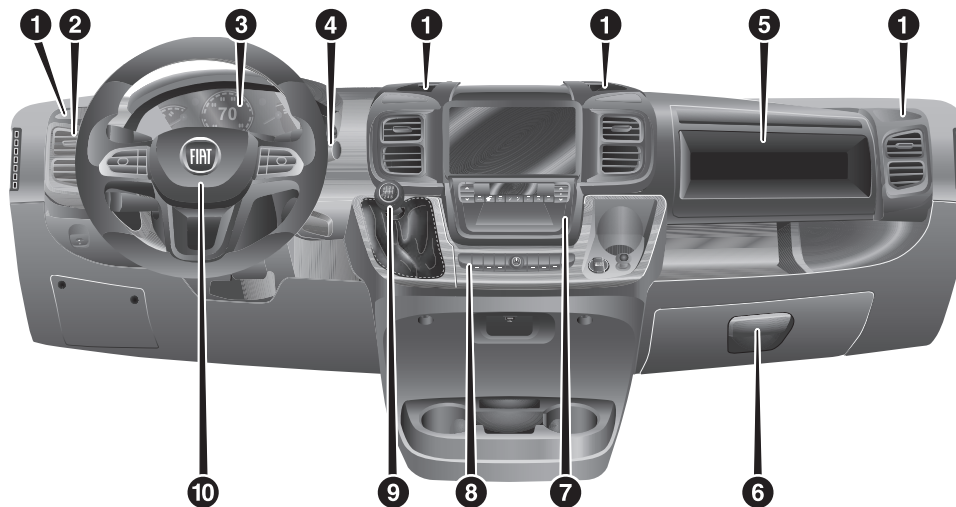

3

F1A0673

|   |    |
|---|----|
| <b>1</b> AIR VENTS                                  |    |
| <input type="checkbox"/> Vents                      | 47 |
| <b>2</b> LEFT STALK                                 |    |
| <input type="checkbox"/> External lights            | 39 |
| <b>3</b> INSTRUMENT PANEL                           |    |
| <input type="checkbox"/> Instrument panel features  | 83 |
| <input type="checkbox"/> Warning lights             | 94 |
| <b>4</b> RIGHT STALK                                |    |
| <input type="checkbox"/> Window washing             | 44 |
| <b>5</b> GLOVE COMPARTMENT / PASSENGER FRONT AIRBAG |    |

|   |     |
|---|-----|
| <input type="checkbox"/> Interior fittings                | 70  |
| <input type="checkbox"/> Front airbag                     | 150 |
| <b>6</b> GLOVE COMPARTMENT                                |     |
| <input type="checkbox"/> Interior fittings                | 70  |
| <b>7</b> HEATER / CLIMATE CONTROL SYSTEM                  |     |
| <input type="checkbox"/> Heating and ventilation          | 48  |
| <input type="checkbox"/> Manual climate control system    | 51  |
| <input type="checkbox"/> Automatic climate control system | 54  |
| <b>8</b> DASHBOARD CONTROLS                               |     |
| <input type="checkbox"/> Parking sensors                  | 182 |

|   |     |
|---|-----|
| <input type="checkbox"/> Heated rear window         | 49  |
| <input type="checkbox"/> Lane Control System        | 129 |
| <input type="checkbox"/> Hazard warning lights      | 223 |
| <input type="checkbox"/> Door locking               | 19  |
| <input type="checkbox"/> Traction Plus              | 119 |
| <input type="checkbox"/> Hill Descend Control       | 116 |
| <b>9</b> GEAR LEVER                                 |     |
| <input type="checkbox"/> Operation                  | 165 |
| <b>10</b> STEERING WHEEL                            |     |
| <input type="checkbox"/> Adjustment                 | 35  |
| <input type="checkbox"/> Driver's side front airbag | 150 |



## Dashboard (versions with Uconnect™ Radio 5" system)

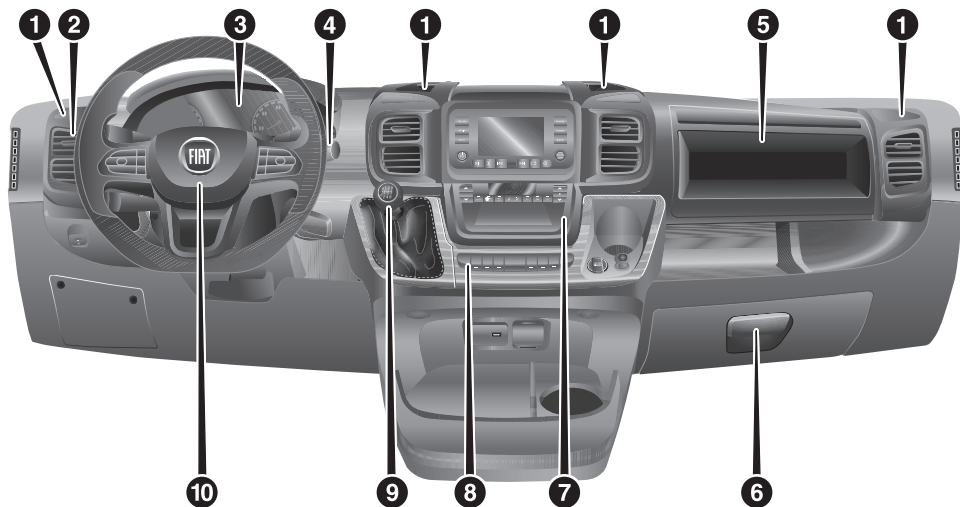

4

F1A0684

**1** AIR VENTS

Vents . . . . . 47

**2** LEFT STALK

External lights . . . . . 39

**3** INSTRUMENT PANEL

Instrument panel features . . . . . 83

Warning lights . . . . . 94

**4** RIGHT STALK

Window washing . . . . . 44

**5** GLOVE COMPARTMENT / PASSENGER FRONT AIRBAG

Interior fittings . . . . . 70

Front airbag . . . . . 150

**6** GLOVE COMPARTMENT

Interior fittings . . . . . 70

**7** HEATER / CLIMATE CONTROL SYSTEM

Heating and ventilation . . . . . 48

Manual climate control system . . . . . 51

Automatic climate control system . . . . . 54

**8** DASHBOARD CONTROLS

Parking sensors . . . . . 182

Heated rear window . . . . . 49

Lane Control System . . . . . 129

Hazard warning lights . . . . . 223

Door locking . . . . . 19

Traction Plus . . . . . 119

Hill Descend Control . . . . . 116

**9** GEAR LEVER

Operation . . . . . 165

**10** STEERING WHEEL

Adjustment . . . . . 35

Driver's side front airbag . . . . . 150

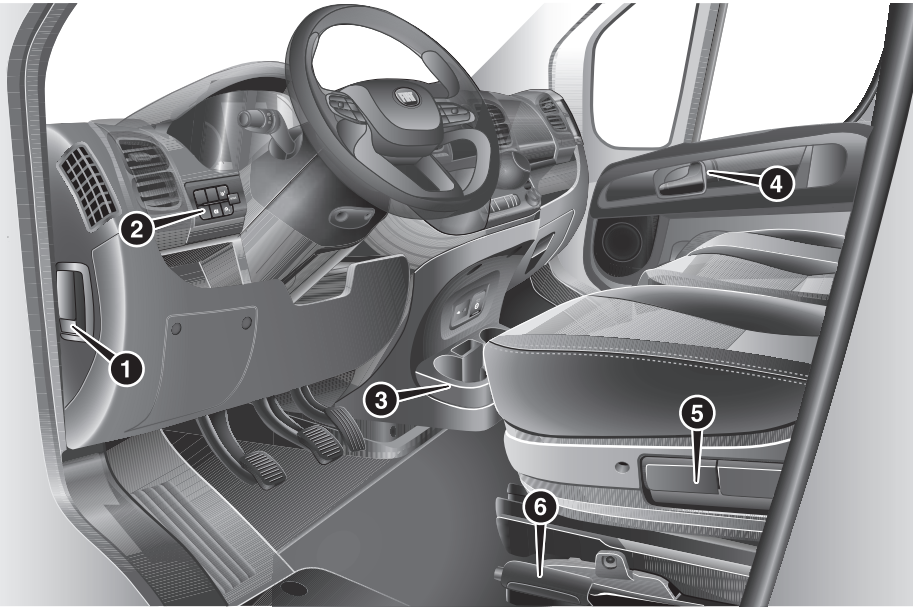

5

F1A0601

|                                    |    |
|------------------------------------|----|
| <b>1</b> BONNET OPENING LEVER      |    |
| □ Opening/closing . . . . .        | 68 |
| <b>2</b> CONTROL PANEL             |    |
| □ Control buttons . . . . .        | 87 |
| <b>3</b> CUP / CAN / BOTTLE HOLDER |    |
| □ Equipment . . . . .              | 70 |
| <b>4</b> DOORS                     |    |
| □ Lock/Unlock . . . . .            | 19 |

|  |     |
|--|-----|
| <b>5</b> SEATS                             |     |
| □ Adjustments . . . . .                    | 27  |
| □ Sprung seat . . . . .                    | 27  |
| □ Seats with adjustable armrests . . . . . | 27  |
| □ Revolving seat . . . . .                 | 27  |
| □ seat . . . . .                           | 27  |
| <b>6</b> PARKING BRAKE                     |     |
| □ Operation . . . . .                      | 160 |



# KNOWING YOUR VEHICLE

*In-depth knowledge of your new vehicle starts here.*

*The handbook that you are reading simply and directly explains how it is made and how it works.*

*That's why we advise you to read it seated comfortably on board, so that you can see what is described here for yourself.*

|  |    |                          |    |
|--|----|--------------------------|----|
| SYMBOLS .....                            | 11 | ELECTRIC WINDOWS .....   | 68 |
| VEHICLE MODIFICATIONS / ALTERATIONS..... | 11 | BONNET .....             | 68 |
| THE FIAT CODE SYSTEM .....               | 11 | HEAD RESTRAINTS .....    | 70 |
| THE KEYS.....                            | 12 | INTERIOR FITTINGS .....  | 70 |
| IGNITION DEVICE .....                    | 16 | TACHOGRAPH.....          | 77 |
| ELECTRONIC ALARM.....                    | 18 | SELF-LEVELLING AIR       |    |
| DOORS .....                              | 19 | SUSPENSION.....          | 77 |
| SEATS.....                               | 27 | ROOF RACK/SKI RACK.....  | 78 |
| STEERING WHEEL.....                      | 35 | ACCESSORIES PURCHASED BY |    |
| REAR-VIEW MIRRORS .....                  | 36 | THE OWNER.....           | 79 |
| EXTERNAL LIGHTS .....                    | 39 | PROTECTING THE           |    |
| CEILING LIGHTS.....                      | 43 | ENVIRONMENT .....        | 80 |
| WINDOW WASHING .....                     | 44 |                          |    |
| VENTS.....                               | 47 |                          |    |
| HEATING AND VENTILATION .....            | 48 |                          |    |
| HEATING AND VENTILATION                  |    |                          |    |
| CONTROLS .....                           | 49 |                          |    |
| MANUAL CLIMATE CONTROL                   |    |                          |    |
| SYSTEM .....                             | 51 |                          |    |
| AUTOMATIC CLIMATE                        |    |                          |    |
| CONTROL SYSTEM .....                     | 54 |                          |    |
| ADDITIONAL HEATER .....                  | 59 |                          |    |
| INDEPENDENT ADDITIONAL                   |    |                          |    |
| HEATER .....                             | 59 |                          |    |
| REAR AIR CLIMATE CONTROL                 |    |                          |    |
| SYSTEM FOR PASSENGER                     |    |                          |    |
| TRANSPORT .....                          | 67 |                          |    |



## SYMBOLS

Some vehicle components have coloured labels whose symbols indicate precautions to be observed when using this component. Under the bonnet there is also a label that summarises all the symbols.

## VEHICLE MODIFICATIONS / ALTERATIONS

**WARNING** Any modification or alteration of the vehicle might seriously affect its safety and road holding, thus causing accidents, in which the occupants could even be fatally injured.

## THE FIAT CODE SYSTEM

### IN BRIEF

*This is an electrical engine locking system which increases protection against attempted theft of the vehicle. Operation is automatic, regardless of the fact that the vehicle doors are locked or unlocked.*

*Each key contains an electronic device which modulates the signal emitted when starting by an aerial built into the ignition device. The signal, which changes each time the engine is started, is the "password", by means of which the control unit recognises the key and enables starting.*



### OPERATION

Each time the vehicle is started turning the ignition device to **MAR**, the Fiat CODE system control unit sends a recognition code to the engine control module to deactivate the immobiliser.

The code is sent only if the Fiat CODE system control unit has recognised the code transmitted from the key.

Each time the ignition device is turned to **STOP**, the Fiat CODE system

deactivates the functions of the engine control module.



### IRREGULAR OPERATION

If the code has not been recognised correctly during starting, the warning light  turns on accompanied by the related message on the instrument panel (see chapter "Warning lights and messages").

In this case, return the ignition device to the **STOP** position and then to **MAR**. If the lock persists try again with the spare set of keys. Contact a Fiat Dealership if you still cannot start the engine.

**WARNING** Each key has its own code which must be stored by the system's control unit. Contact a Fiat Dealership to have new keys (up to 8) stored with a code.

### Activation of icon / warning light while driving



- If the  icon/warning light switches on, this means that the system is running a self-diagnosis (for example due to a voltage drop).
- If the  icon/warning light stays on, contact a Fiat Dealership.



 **WARNING**

**1)** *The electronic components inside the key may be damaged if the key is subjected to strong shocks. In order to ensure complete efficiency of the electronic devices inside the key, it should never be exposed to direct sunlight.*

**THE KEYS**

 1)  2) 3)

**MECHANICAL KEY**

(for versions/markets, where provided)

The metal part (A) fig. 6 of the key is fixed.

- The key operates:
- the ignition device;
  - the door lock;
  - opening and closing of the fuel tank cap;
  - the lock on the dashboard drawer;
  - the battery disconnect switch.

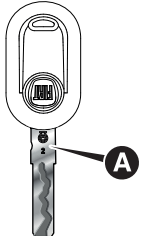

6 F1A0602

**Versions with "Keyless Go" system**

On versions equipped with the "Keyless Go" system, the vehicle is fitted with a mechanical key.

The metal part (A) fig. 7 of the key is fixed.

- The key operates:
- opening and closing of the fuel tank cap;
  - the lock on the dashboard drawer;
  - the battery disconnect switch.

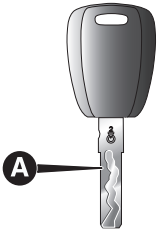

7 F1A0008

**KEY WITH REMOTE CONTROL**

(for versions/markets, where provided)

The metal insert (A) fig. 8, fig. 9 or fig. 10 is retractable and operates:

- the ignition device;
- the door lock;
- opening and closing of the fuel tank cap;

- the lock on the dashboard drawer;
- the battery disconnect switch.

**Version with 3 sensors**

Press button (B) fig. 8 to open/close the metal insert.



8 F1A0616

**Version with 2 sensors**

Press the button (B) fig. 9 or (B) fig. 10 to open/close the metal insert.



9 F1A0616

(Where provided)



10

F1A0844



### Dashboard LED indications

For vehicles not provided with alarm system, when locking the doors, the LED (A) fig. 11 on for about 3 seconds and then starts flashing (deterrence function).

When the doors are locked, if one or more doors are not closed correctly, the LED and direction indicators start flashing quickly.

For vehicles equipped with an alarm system, the LED will flash quickly when the doors are centrally locked for about 3 seconds. The LED will flash more slowly when the alarm is on.

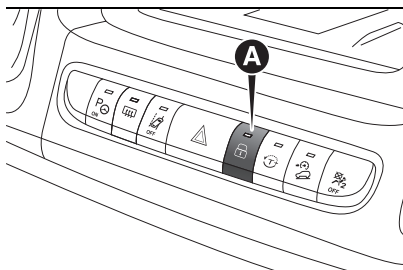

11

F1A0843

### ELECTRONIC KEY

(versions with Keyless Go system)

On versions equipped with "Keyless Go" system, the vehicle has an electronic key fig. 12, of which two copies are provided.

The button configuration may vary depending on the vehicle.





12

F1A0803

### OPERATION

#### Unlocking doors and load compartment

Briefly press the button  /  (where provided): unlocking of the load compartment doors, timed switching-on of internal lights and double flashing of direction indicators (where provided). When the function is available, press and release the unlock button on the remote control once only to unlock the driver's door or twice within 1 second to unlock all doors and the load compartment.

The current setting can be changed using the display Menu or the **Uconnect™** system, for the system to unlock the driver door only or all the doors the first time the button is pressed on the remote control.

For more information, see the "Display" chapter in the "Knowing the instrument panel" section.

The doors can always be unlocked by putting the metal insert inside the driver side door lock.

#### Door lock and load compartment

Briefly press the  "FIAT" /  button: locking of doors and load compartment with ceiling light off and single flash of direction indicators (where provided).



For vehicles with keys with remote control, if one or more doors are open, the doors will not be locked.

This situation is indicated by a rapid flashing of the direction indicators (where provided). The doors will be locked if the load compartment is open instead.

For vehicles with electronic keys, if one or more doors are open, the doors are locked anyway and this is indicated by a rapid flashing of the direction indicators (where provided).

The doors prepare for locking, which is active from the moment they are closed. The doors will unlock again only if the key presence is detected inside the passenger compartment.

### Opening the load compartment

Press the  button once to open the load compartment remotely (where provided).

The direction indicators will flash twice to indicate that the load compartment has been opened.

## REPLACING THE BATTERY IN THE KEY WITH REMOTE CONTROL



To replace the battery, proceed as follows:



13

F1A0617

- apply a small bit screwdriver to the points indicated by the arrows fig. 13 then remove the rear casing (A) fig. 14;

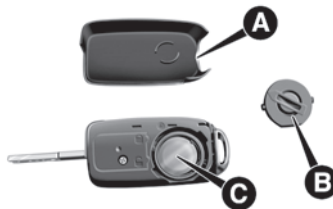

14

F1B0010C

- use a coin to turn inspection flap (B) anticlockwise and remove it;
- replace battery (C) with a new one of the same specifications, respecting its polarity;
- refit flap (B) turning it clockwise, then re-close the rear casing by pressing gently and making sure it is correctly locked.

## REPLACING THE ELECTRONIC KEY BATTERY

To replace the battery, proceed as follows:

- extract the metal insert in the electronic key (see description above);
- gently inserting the flat part of the screwdriver supplied with the vehicle into the seat (A) fig. 15 of the key to open it in two parts;
- remove the battery (B) fig. 16 (CR2032 type);



15

F1A0735



16

F1B0012C

- insert a new battery, making sure that the polarity is correct;
- refit the two parts of the electronic key, ensuring that they are locked correctly;
- reinsert the metal insert in the key.

**WARNING** The battery replacement operation must be carried out with care, in order not to damage the electronic key.

## REQUEST FOR ADDITIONAL KEYS

### Key with remote control

The system can recognise up to 8 keys with remote control.

### Electronic key

To guarantee that the engine starts and the vehicle operates correctly, use only electronic keys specifically coded for the electronics of the vehicle.

If an electronic key is coded for a vehicle, it cannot be used on any other car.

### Duplicating keys

Should a new key with remote control or a new electronic key be necessary, contact a Fiat Dealership, taking an ID document and the vehicle ownership documents.



### IMPORTANT

- 1)** Do not swallow the battery. Danger of chemical burns. The keys contain a small battery. If the battery is swallowed, it can cause severe internal burns in just 2 hours and cause death. Keep new and used batteries out of the reach of children. If the battery compartment does not close securely, discontinue use of the product and keep it out of reach of children. If you believe that batteries may have been swallowed or inserted inside the body, seek medical attention immediately. The emergency key (where provided) must be immediately inserted into the electronic key to prevent easy access to the battery.
- 2)** Button (B) should only be pressed when the key is away from the body, in particular from the eyes and from objects that can be spoiled (e.g. clothes). Do not leave the key unattended to avoid the button being accidentally pressed while it is being handled, e.g. by a child.



### WARNING

- 2)** The electronic components inside the key may be damaged if the key is subjected to strong shocks. In order to ensure complete efficiency of the electronic devices inside the key, it should never be exposed to direct sunlight.
- 3)** Do not place keys near the wireless charger.



### WARNING

- 1)** Used batteries may be harmful to the environment if not disposed of correctly. They must be disposed of as specified by law in the special containers or taken to a Fiat Dealership, which will take care of their disposal.



## IGNITION DEVICE

### Versions with mechanical key

The key can be turned to 3 different positions fig. 17:

- ❑ STOP: engine off, key can be extracted, steering locked. Some electrical devices (e.g. radio, central door locking system, etc.) can operate;
- ❑ MAR: driving position. All electrical devices are enabled;
- ❑ AVV: engine starting (unstable position).

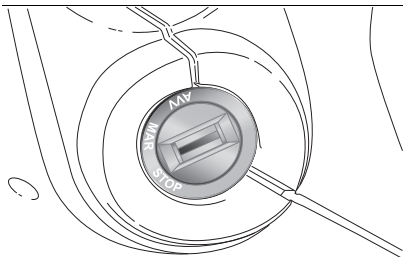

17

F1A0009

The ignition device is fitted with an electronic safety system that requires the ignition key to be turned back to STOP if the engine does not start, before the starting operation can be repeated.

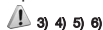

### Versions with electronic key ("Keyless Entry" system)

To activate the ignition device fig. 18 the electronic key must be inside the passenger compartment within the first row of seats fig. 19.



18

F1A0610

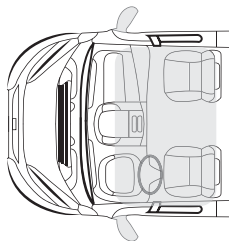

19

F1A0736

The ignition device has the following possible states:

- ❑ STOP: engine off, steering column locked. Some electrical devices (e.g. central door locking system, alarm, etc.) are still available;

- ❑ MAR: driving position. All electrical devices are available. This state can be entered by pressing the ignition device button once, without pressing the brake pedal (versions with automatic transmission/dual clutch automatic transmission) or the clutch pedal (versions with manual transmission);
- ❑ AVV: engine starting.



NOTE With the ignition device at MAR, if 30 minutes pass with the vehicle stationary (versions with manual transmission) or with the gear lever at P (Park) (versions with automatic transmission/dual clutch automatic transmission) and the engine off, the ignition device will automatically move to the STOP position.

NOTE With the engine running, it is possible to go away from the vehicle taking the electronic key with you. The engine will still be running. The vehicle will indicate the absence of the key on board when the door is closed.

NOTE If the device does switch off the vehicle, refer to the "Knowing the instrument panel" section of the "Display" chapter, where provided, and contact the Fiat Dealership as soon as possible. For more information on the engine start-up, see the description in the "Starting and driving" section of the "Starting the engine" chapter.

## STEERING COLUMN LOCK

### Activation

*Versions with mechanical key.* with the device at STOP, remove the key and turn the steering wheel until it locks.

**WARNING** If the ignition key has been moved from the MAR to the STOP position, the steering lock cannot engage until the key is removed from the ignition device.

*Versions with electronic key.* the steering lock engages when the driver door is opened, with the starter switch button at STOP and speed below 3 km/h.

### Deactivation

*Versions with mechanical key.* slightly moving the steering wheel, turn the key to the MAR position.

*Versions with electronic key.* the steering column lock disengages when the ignition device is pressed and the electronic key is recognised.

**WARNING** To release the key smoothly on versions with automatic transmission/dual clutch automatic transmission, it is advisable to put the gear lever in the P position, release the

brake pedal safely and then stop the engine.



### Extracting the ignition key for versions with automatic transmission

If the engine is switched off with the gear lever in position P; move the lever to P within 5 seconds. If the engine is switched off with the gear lever in position P; move the lever to P within 5 seconds. Then it will be possible to remove the ignition key for about 30 seconds. If the described conditions and times are not respected, the ignition key will be automatically locked. To remove the ignition key, turn it to MAR and then to STOP repeating the procedure described above.



### IMPORTANT

- 3)** *If the ignition device has been tampered with (e.g. attempted theft), have it checked over by a Fiat Dealership before driving again.*
- 4)** *Always take the key with you when you leave your vehicle to prevent someone from accidentally operating the controls. Remember to engage the parking brake. Engage first gear if the vehicle is parked uphill or reverse gear if the vehicle is*

*parked downhill. Never leave children unattended in the vehicle.*

**5)** *Never extract the key while the vehicle is moving. The steering wheel will automatically lock as soon as it is turned. This also applies to cases in which the vehicle is towed.*

**6)** *It is absolutely forbidden to carry out any aftermarket operation involving steering system or steering column modifications (e.g. installation of anti-theft device) that could adversely affect performance, invalidate the warranty, cause serious safety problems and also result in the vehicle not meeting type-approval requirements.*

**7)** *Before leaving the vehicle, ALWAYS engage the parking brake. On versions with automatic transmission/dual-clutch automatic transmission, move the gear lever to P (Park) and press the ignition device to set it to STOP. When leaving the vehicle, always lock all the doors by pressing the button on the handle.*

**8)** *For versions equipped with the Keyless Entry system, do not leave the electronic key inside or near the vehicle or in a place accessible to children. Do not leave the vehicle with the ignition device in MAR position. A child could activate the electric window winders, other controls or even start the vehicle.*

**9)** *Never extract the mechanical key while the vehicle is moving. The steering wheel will automatically lock as soon as it is turned. This also applies to cases in which the vehicle is towed.*

**10)** *It is absolutely forbidden to carry out any after-market operation involving steering system or steering column modifications (e.g. installation of anti-theft*





*device) that could adversely affect performance, invalidate the warranty, cause serious safety problems and also result in the car not meeting type-approval requirements.*

## **ELECTRONIC ALARM**

(for versions/markets, where provided)  
The alarm, in addition to all the remote control functions described previously, is controlled by the receiver located under the dashboard near the fusebox.

### **OPERATION**

The alarm intervenes in the following instances:

- wrongful opening of a door or the bonnet (perimeter protection);
- when the ignition system is started up (ignition key turned to MAR-ON);
- cutting of the battery leads.

Depending on the market, activation of the alarm may cause the siren and the direction indicators to activate (for about 26 seconds). Alarm tripping and the number of cycles depend on the sales market.

There is a maximum number of acoustic/visual cycles. When this is reached the system returns to normal operation.

**WARNING** The engine stop function is guaranteed by the Fiat CODE, which

is automatically activated when the ignition key is extracted from the ignition switch.

### **ACTIVATION**

With the doors and bonnet closed and the ignition key either turned to STOP or removed, point the key with the remote control towards the vehicle and press and release the or lock button or locking the vehicle using the Passive Entry/ Keyless Entry system.

Excluding some markets, the system produces an acoustic warning (beep) and enables door locking.

The turning on of the alarm is preceded by a self-diagnosis stage: if a fault is detected, the system produces another acoustic warning.

In this case, turn the alarm off by pressing the "release doors/release load compartment" button or unlock the vehicle using the Passive Entry/Keyless Entry system, check that the doors and bonnet are properly closed and turn the alarm back on by pressing the lock button.

If a door or the bonnet is not properly shut, it will be excluded from the testing by the alarm system.

If the alarm produces an acoustic warning even when the doors and bonnet are correctly closed, a fault

has occurred in the operation of the system. Contact a Fiat Dealership.

**WARNING** The alarm does not come on when the central locking is activated using the metal insert of the key.

**WARNING** The alarm is adapted to meet requirements in various countries.

### **DEACTIVATION**

Press the "unlock door/unlock load compartment" button on the key with remote control or unlock the vehicle using Passive Entry/Keyless Entry system.

The following operations are performed (excluding some markets):

- direction indicators flash twice;
- two brief acoustic signals ("beeps");
- doors are unlocked.

**WARNING** The alarm does not switch off when the central opening is activated using the metal insert of the key.

### **BREAK IN ATTEMPT INDICATION**

In the event of a break-in attempt, the  warning light on the instrument panel turns on (see the "Warning lights and messages" chapter in the



"Knowing the instrument panel" section).

## DISARMING THE ALARM



To permanently disable the alarm (e.g. during a long period of inactivity), simply lock the vehicle by turning the metal insert of the key with remote control in the lock.

**WARNING** If the batteries of the key with remote control run out or in case of a system fault, the alarm can be switched off by placing the key in the ignition device and turning it to MAR.

## DOORS

### DOOR CENTRAL LOCKING/UNLOCKING



#### Locking from the outside

With the doors closed, press the  "FIAT" /  button on the key fig. 20, fig. 21, fig. 22, fig. 23 or insert and turn the metal insert (A) in the driver's door lock clockwise. The doors will only be locked if all doors are shut.



Press button (B) to open/close the metal insert.

If one or more of the doors is open after the  "FIAT" /  button on the remote control is pressed, the direction indicators and the LED in the button (A) fig. 24 will flash quickly for about

3 seconds. With the function on, the button (A) fig. 24 is disabled.

Double-tapping on the  "FIAT" /  button on the remote control activates the dead lock device (see "Dead lock" paragraph).

#### Door unlocking from the outside

Briefly press button  fig. 20, fig. 21 or fig. 23, or  fig. 22 (where provided), according to the version, to remotely unlock the front doors, switch on the ceiling lights or, where provided, in a timed manner and flash the direction indicators.

#### Version with 3 sensors



20

F1A0615

#### Version with 2 sensors



21

F1A0616

(Where provided)



22

F1A0844





23

F1A0603

### Locking/unlocking doors from the inside

Press the button (A) fig. 24 to lock the doors and press it again to unlock them. Locking / unlocking is centralised (front and rear).

When the doors are locked, the LED in button (A) is on and, when the button is pressed again, all the doors are centrally unlocked and the LED is switched off.

When the doors are unlocked, the LED is off and pressing the button again centrally locks all the doors. The doors will be locked only if all the doors are properly shut.

After locking the doors with the key with remote control or by turning the metal insert in the door latch, it will not be possible to unlock them using the button (A) fig. 24 on the dashboard.

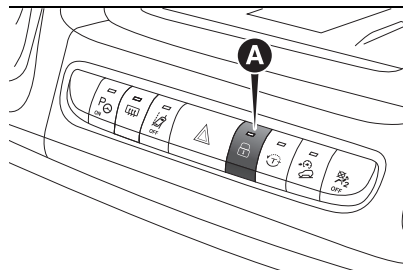

24

F1A0643

**WARNING** For versions with automatic transmission and central locking already engaged, positioning the gear lever in the "P" position and operating the opening lever of one of the two front doors to disengage the central locking system. If central locking function is used with the gear lever already in the "P" position, the doors will not unlock centrally when the door opening lever is operated. For versions with manual transmission and central locking already engaged, with the clutch lever released, acting on the opening lever of one of the two front doors will disengage the central locking system. The doors will not be unlocked centrally if the door opening lever is operated before the clutch lever is released. The Setup Menu can be used to select whether to unlock the front only or the entire vehicle when either front door is opened.

If a power supply is not present (blown fuse, battery disconnected, etc.) it is, however, possible to lock the doors manually.

While travelling, at speeds exceeding 20 km/h, all the doors will be locked automatically if the function was selected in the Setup menu.

### PASSIVE ENTRY/KEYLESS ENTRY

(where provided)



The Passive Entry/Keyless Entry can identify the presence of an electronic key near the doors of the vehicle.

The system allows the doors to be locked/unlocked without pressing any buttons on the electronic key.

If the system identifies the electronic key detected outside the vehicle as a valid one, the key holder can simply press the button (A) fig. 25 on one of the two outer handles to deactivate the alarm and release the door opening mechanism.

Where the function is provided, pressing the button (A) on the driver's door unlocks the driver's side door or all doors depending on the mode set using the display menu or the **Uconnect™** system.

## Door locking / unlocking

To lock/unlock the doors, proceed as follows:

- make sure that you have the electronic key with you and are near the driver or passenger door handle;
- press the door locking/unlocking button (A) fig. 25 on the handle: this will lock/unlock all doors. Locking the doors will also activate the alarm (where provided).

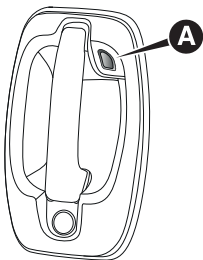

25

F1A0661

**WARNING** After pressing the "door locking" button, you need to wait two seconds before the doors can be unlocked again using the door handle. It is therefore possible to check whether the vehicle is locked correctly by pulling the door handle within 2 seconds. The doors will not be unlocked again.

The vehicle doors can be locked anyway pressing the  button on the electronic key or on the inner panel.

## Driver side door emergency opening

If the electronic key does not work (e.g. because its battery is flat), the emergency metal insert inside the key can anyway be used to operate the lock, unlocking the driver side door. To extract the metal insert, proceed as follows:

- use the device (A) fig. 26 and remove the metal insert (B) pulling it outwards;
- insert the metal insert in the driver side door lock and turn it to unlock the door.

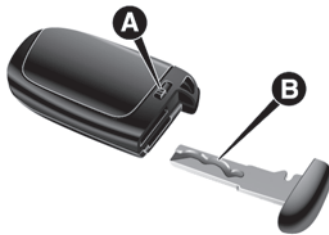

26



F1B0020C

**NOTE** The metal insert of the key has no forced insertion direction and can be inserted indifferently in the lock.

**WARNING** To avoid leaving the electronic key inside the vehicle accidentally, the Passive Entry/Keyless Entry function features an automatic door unlocking function which operates if the ignition device is at OFF.

If one of the vehicle doors is open, and the "door lock"  button (A) fig. 25 located on one of the front door handles is pressed, or the button on the inner panel fig. 24, once all the open doors are closed, the vehicle checks inside and outside the vehicle for the presence of enabled electronic keys.

If one of the electronic keys is detected inside the vehicle and no other active electronic key is detected outside the vehicle, the Passive Entry/Keyless Entry function automatically unlocks all the vehicle doors and operates the direction indicators.

If, on the contrary, one or more electronic keys are inside the passenger compartment, pressing the button  on the remote control the keys inside the passenger compartment are temporarily disabled. To re-activate their correct operation, press the button  on the remote control.

## Notes

The vehicle will **unlock** the doors if one

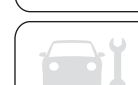

of the following conditions is met:

- the doors were closed by pressing the button  in the inner panel;
- a valid electronic key is detected inside the vehicle and, outside the vehicle, no other electronic key is detected.

The vehicle will **not unlock** the doors if one of the following situations is present:

- if the doors have been locked manually using the door locking knobs (or the metal insert of the key, for the driver's door only);
- an electronic key close to the vehicle has been detected outside.

When the Passive Entry/Keyless Entry function is disabled using the display Menu or the **Uconnect™** system, the devices which provide protection against accidentally leaving the electronic key in the vehicle remain active.

### Access to the load compartment

When approaching the sliding side door or the rear doors of the load compartment with the valid electronic key, press the button to lock/unlock (A) fig. 25 on the handle.

NOTE If an alarm system is present, the latter will be temporarily disabled only for the load compartment area.

After closing the doors of the load compartment, the alarm system will be reactivated again.

WARNING If only the load compartment doors are unlocked and a key is detected inside the load compartment when closing the doors, the doors will remain open and the direction indicators will flash twice.

**WARNING Before driving make sure that the load compartment doors are closed correctly.**

### Load compartment door lock

The doors of the load compartment of the vehicle can be locked by pressing the button  on the electronic key or on the interior panel, or by pressing the button (A) on the handle fig. 25.

NOTE The opening of the load compartment is disabled while the vehicle is moving.

While driving, if the load compartment doors are closed correctly, they will be locked automatically when the speed is faster than 20 km/h together with the doors ("Autoclose" function). This function can also be disabled using the menu on the instrument panel.

### System activation/deactivation

The Passive Entry/Keyless Entry system can be activated/deactivated

through the display Menu or the **Uconnect™** system.

### MECHANICAL LOCK OF PASSENGER SIDE CAB DOOR IN CASE OF EMERGENCY



This is a device which allows the passenger side cab door to be locked mechanically, to prevent it from being opened from the outside, if no power supply is available (battery disconnected).

The device in fig. 27 can be engaged only with the passenger side cab door open.

Proceed as follows:

- insert the key in device (A) and move it upwards as shown in the figure to lock the door fig. 27;
- close the door.

Check that the door has locked by trying the outside handle.

To unlock the device, operate the inside handle of the passenger side cab door or, if battery power has been restored, press button  /  (where provided) on the key.

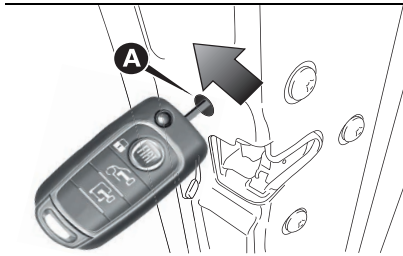

27

F1A0618

## LOCKING/UNLOCKING THE LOAD COMPARTMENT

Lock activation is indicated by the LED in the button (D) fig. 28.

The LED comes on in the following cases:

- after each door lock command generated by the button (D) fig. 28 or by button  in the dashboard;
- when the lock buttons on the key are pressed;
- when the Passive Entry/Keyless Entry system is used;
- when the instrument panel is activated;
- upon opening of one of the front doors;
- when the door is locked at 20 km/h (if activated using the menu).

The lock is turned off when one of the load compartment doors is opened or on a door release request (load

compartment or centralised) or an unlocking request from the remote control/door latch or by using the Passive Entry/Keyless Entry.

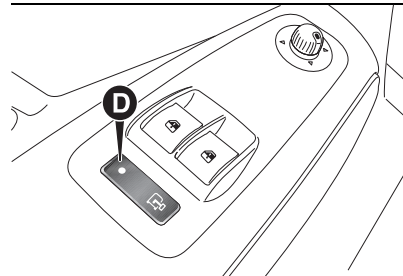

28

F1A0761

## DEAD LOCK DEVICE

(for versions/markets, where provided)

It is a safety device that disables operation of the interior handles. Press the lock/unlock button (A) fig. 24 to prevent opening the doors from inside the passenger compartment in the event of an attempted break-in (e.g. when a window is broken).

The dead lock device therefore offers the best possible protection against break in attempts. We recommend engaging it whenever the vehicle is parked and left unattended.



### Device activation

The dead lock device is automatically activated on every door with two short

presses on the button  on the key with remote control fig. 23.

For vehicles equipped with the Passive Entry/Keyless Entry system, Dead Lock is activated every time the vehicle is locked using the button on the outside handle.

The direction indicators flash 3 times and the LED on the button (A) fig. 24 among the dashboard controls flashes to indicate that the device has been turned on.

If one or more of the doors is not perfectly shut, the dead lock device will not be activated, thus preventing a person getting into the vehicle through the open door and, on shutting, it, remaining stuck inside the passenger compartment.

The device will not engage with the key in the MAR position. The device is only activated with the key in the STOP position.

### Device deactivation

The system is disabled automatically on every door in the following cases:

- if the mechanical key is turned to the opening position in the driver's door;
- by unlocking the doors using the remote control;
- by turning the ignition key to the MAR position.

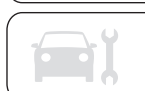

## SLIDING SIDE DOOR

 12) 13)

To open the sliding side door, lift the handle (A) fig. 29 and accompany the door in the opening direction.

The sliding side door is equipped with a stop that prevents it sliding beyond the end of its travel when opening.

To close, operate the exterior handle (A) (or the corresponding interior handle) and push to closed.

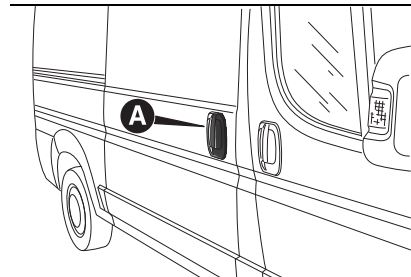

29

F1A0117

In any case, make sure that the door is correctly attached to the device that holds it fully open.

## CHILD SAFETY DEVICE

(for versions/markets, where provided)

This system prevents the sliding side doors being opened from the inside.

The device fig. 30 can be engaged only with the sliding side door open:

- Position (1): Device not engaged (door may be opened from the inside);
- Position (2): Device engaged (door locked).

The device stays on even if the doors are electrically unlocked.

 14)

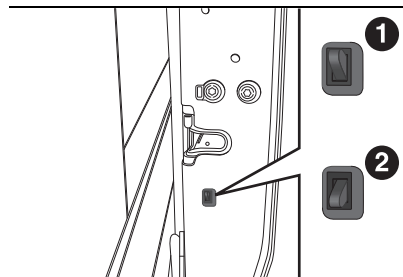

30

F1A0143

## SLIDING SIDE WINDOW

(for versions/markets, where provided)

To open, keep the two handles (B) fig. 31 pressed toward one another and slide the window.

When the two handles are released, the sliding glass may stop in intermediate positions.

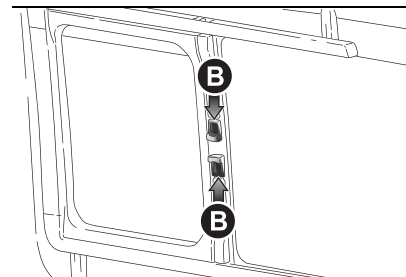



31

F1A0118

## DOUBLE REAR SWING DOOR

 15) 16)

### Manual opening of the first swing door from the outside

Press the  button on the remote control (version with three buttons, fig. 20) or the button  /  (where provided) on the remote control (version with two buttons, fig. 21, fig. 22) and operate the handle (A) fig. 32 in the direction indicated by the arrow.

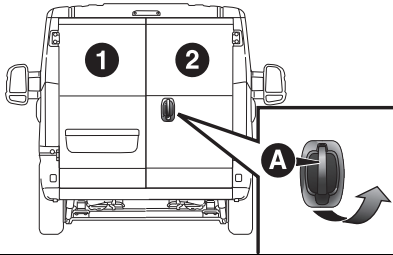

32

F1A0120

### Manual opening of the first swing door from the inside

(for versions/markets, where provided)  
Pull the lever (B) fig. 33 in the direction indicated by the arrow.

### Manual closure of the first swing door from the outside

Press button  on the key with the remote control. Close the left door first, followed by the right door.

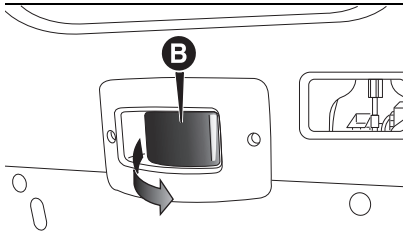

33

F1A0121

### Manual opening of the second swing door

Pull the lever (C) fig. 34 in the direction indicated by the arrow.

The double rear swing doors have two opening positions: the first to an angle of approximately 90° and the second is approximately 180°; on some trim versions/markets 270° opening is also available. To open the swing doors to 180°, or 270° (for versions/markets where provided), proceed as follows:

- reach the 90° door opening position;
- keep pulling the door to press a force to allow them to open to 180° or to 270° (for versions/markets where provided).

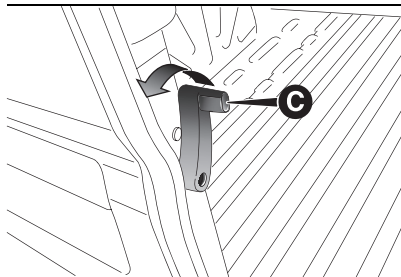

34

F1A0122

### Electric locking from inside

Close the two rear swing doors (first left, then right) and press the button (D) fig. 35 on the electric window control panel.

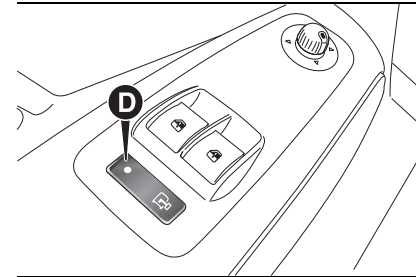

35

F1A0761

### MOVING FOOTBOARD

(for versions/markets, where provided)

When the side door of the passenger compartment or luggage compartment is opened, a footboard emerges from the lower part of the floorpan fig. 36 to make it easier to board the vehicle.

 17) 18) 19) 20) 21)

 5)

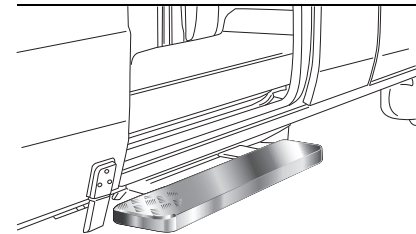

36

F1A0119





**REAR FOOTBOARD**

(for goods carrier van versions)

 17) 18) 19) 20) 21)

 5)

The vehicle can be equipped with a rear retractable footboard (A) fig. 37, which aids climbing into and out of the rear load compartment.

The footboard can slide under the vehicle when not used so as not to increase the vehicle external dimensions.

The footboard slides manually both when opening and closing.

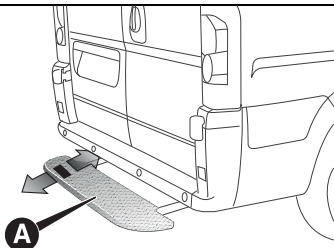

37

F1A0410

**IMPORTANT**

**11)** Once the dead lock device is engaged it is impossible to open the doors from inside the vehicle. Before engaging the system please therefore check that there is no-one left on board. If the remote control battery is flat, the system can be

disengaged only by inserting the key metal insert in either of the door locks as described previously: in this case the device remains active only for the rear doors.

**12)** Before leaving the vehicle parked with sliding doors open, always check that the latch is engaged.

**13)** Do not move the vehicle with side doors open.

**14)** Always use this device when carrying children.

**15)** This spring loaded system has activation forces that were designed for optimum comfort. Accidental knocks or a strong gust of wind may release the springs and let the doors close spontaneously.

**16)** With the doors opened to 180 degrees and 270 degrees, no locking system is effective. Do not use this opening with the vehicle parked on a gradient or when it is windy.

**17)** It is forbidden to drive the vehicle with the footboard open.

**18)** Do not use the retracted footboard for getting up or down the load compartment.

**19)** Make sure that the footboard is suitably locked by the provided retaining systems before, after and during its use. An incomplete opening or closing might cause an improper movement of the footboard with risks arising for the operator and external users.

**20)** Before setting off after parking or before moving the vehicle in any way, ensure the footboard is fully stowed away. As the movement of the platform is linked to that of the sliding side door, the dedicated symbol appears on the

instrument panel display if it is not fully retracted in the same way as if the rear doors are not shut.

**21)** The footboard lightly projects from the vehicle even if retracted; therefore, when rear parking sensors are provided, their operating range is lightly reduced.

**WARNING**

**4)** The operation of the recognition system depends on various factors, such as, for example, any electromagnetic wave interference from external sources (e.g. mobile phones), the state of charge of the battery in the electronic key and the presence of metal objects near the key or the vehicle. In these cases it is still possible to unlock the doors by using the metal insert in the electronic key (see description on the following pages).

**5)** The footboard presence may reduce the ramp approach angles; it is therefore recommended, in case of a very steep ramp, to be very careful in order not to damage the footboard.



## SEATS



### Longitudinal adjustment

Lift lever (A) fig. 38 and push the seat forwards or backwards: in the driving position, you should be able to rest your arms on the steering wheel rim.

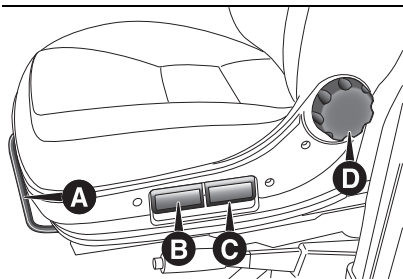

38

F1A0021

### Height adjustment

**To raise the seat:** while seated, move the lever (B) fig. 38 (front part of the seat) or the lever (C) fig. 38 (rear part of the seat) upwards and lift your body weight off the part of the seat that must be raised.

**To lower the seat:** while seated, move the lever (B) (front part of the seat) or the lever (C) (rear part of the seat) upwards and press your body weight off the part of the seat that must be lowered.

### Backrest angle adjustment

Turn knob (D) fig. 38.



### Lumbar adjustment

Operate the knob (E) fig. 39 to adjust.

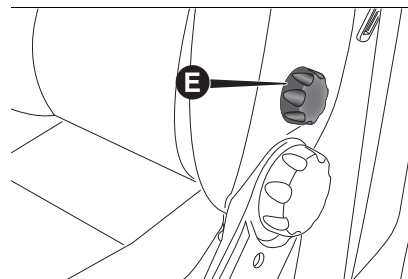

39

F1A0022

### Front heated seats

(where provided)

The heated front seats, where provided, are controlled in ON/OFF mode with the physical button (E) fig. 40 positioned in the lower part of the seat facing outwards.

With the key at MAR, press button (E) to switch the function on/off.

**IMPORTANT** In order to preserve the battery, this feature cannot be activated when the engine is off.

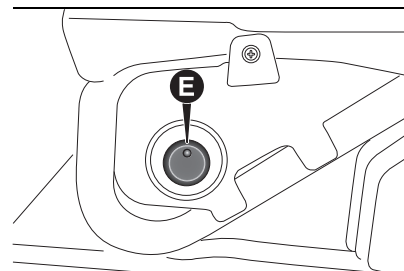

40

F1A0030

### SPRUNG SEAT

The seat is equipped with a mechanical spring system and hydraulic shock absorber to ensure maximum comfort and safety. The system of springs also effectively absorbs impact from uneven road surfaces.

See the description in this chapter for the lengthwise adjustments, height adjustments, backrest adjustment, lumbar adjustment and armrest adjustment.

### Shock absorber weight adjustment

Use the knob (A) fig. 41 to set the desired adjustment according to your body weight, in the range 40 kg to 130 kg.



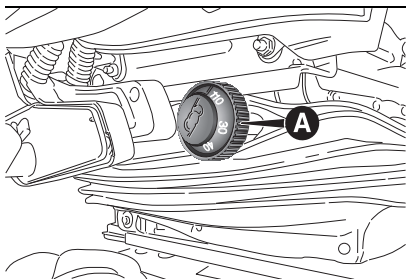

41

F1A0023

### SEATS WITH ADJUSTABLE ARMRESTS

The driver and passenger seats may be equipped with an armrest that can be raised and adjusted for height. Operate the wheel (A) fig. 42 to adjust.

25) 26)

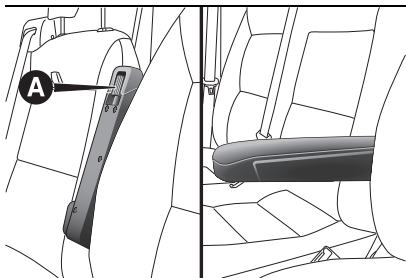

42

F1A0024

### SEAT WITH REVOLVING BASE

(for versions/markets, where provided)  
It may be turned through 180° toward

the seat on the opposite side. Operate the control (A) fig. 43 to turn the seat. Before turning the seat, it must be moved forward and only then adjusted longitudinally fig. 44.

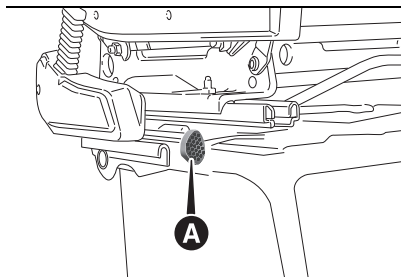

43

F1A0025

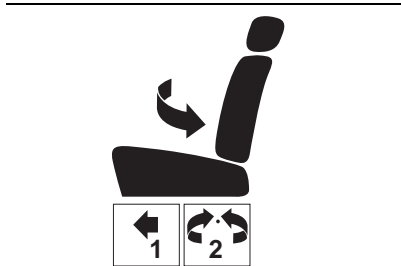

44

F1A0026

### REVOLVING SEAT WITH SEAT BELT

(for versions/markets, where provided)  
It is equipped with a three-point seat belt fig. 45, two adjustable armrests (for

their adjustment, see the "Seats with adjustable armrests" paragraph) and a head restraint with adjustable height (adjusting it, see the "head restraints" paragraph).

27)

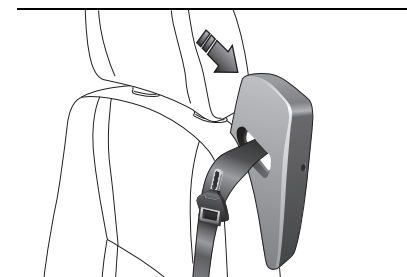

45

F1A0027

### Backrest angle adjustment

Operate the lever (A) fig. 46.

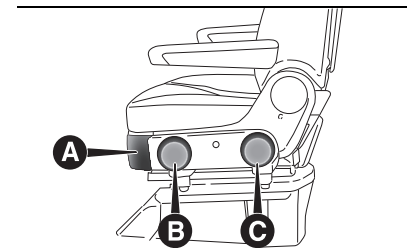

46

F1A0028

## Height adjustment

Operate the controls (B) fig. 46 or (C) fig. 46 to raise or lower the front/rear part of the seat, respectively.

## Seat rotation

It may be turned through 180° toward the seat on the opposite side and approximately 35° toward the door. It may be locked in driving position or at 180°.

Operate the lever (D) fig. 47 (located on the right side of the seat) to turn the seat.

Before turning the seat, it must be moved forward and only then adjusted longitudinally fig. 44.

 28)

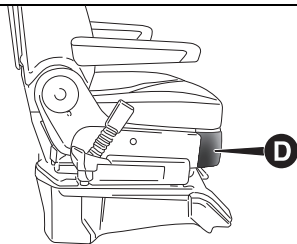

47

F1A0029

## CAPTAIN CHAIR

(for versions/markets, where provided)

The vehicle may be equipped with the Captain Chair fig. 48, which, depending on the version, may have various

adjustments (revolving or fixed, with seat belt, etc.) or heated.

For the various adjustments refer to what is described in the previous paragraph "Revolving seat with seat belt").

## FLAP ON BENCH

(for versions/markets, where provided)

The seat is equipped with a fold-down flap that can be used as a document support surface. To use, pull the tab (A) fig. 49 and lower the flap. The flap is equipped with two cup holder indents and a support surface with a paper holder clip.

 29)



48

F1A0345

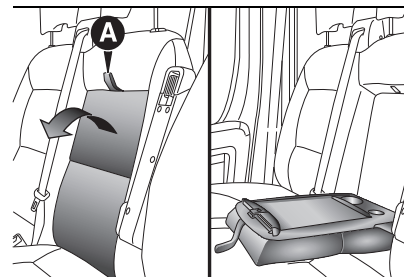

49

F1A0031



## EAT&WORK TABLE

(for versions/markets, where provided)

The seat is equipped with a folding table. To extract the table:

- pull the tab (A) fig. 50;
- accompany the armrest throughout its travel until it is horizontal.

The table has a glass holder, a storage compartment and a shelf that can rotate (3 positions on each side: 20°, 40°, 60° fig. 52).

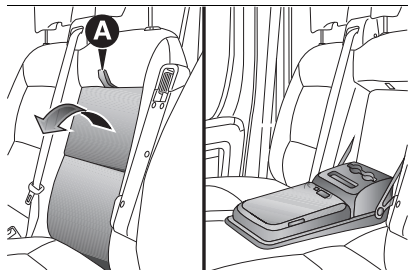

50

F1A0726

### Table rotation to the right (passenger side)

- Press the (A) fig. 51 button;
- push the table with a certain force indicated by the arrow fig. 51;
- the table will rotate to the first of the intermediate positions fig. 52. Continue pushing to reach the second position and then the final position. Each position will be perceived with stops;

- no buttons need to be pressed to return to the closed position. It will be sufficient to push in the area indicated by the arrow fig. 52 to overcome all the intermediate steps.

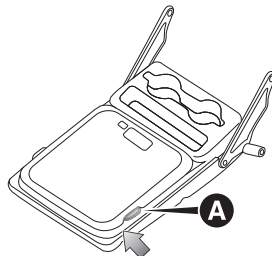

51

F1A0727

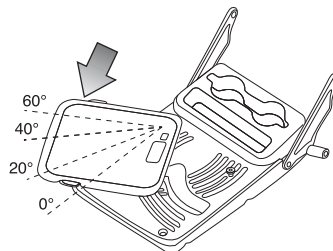

52

F1A0728

**WARNING** Never use the table while the vehicle is moving.

## CARGO SPACE

(For versions/markets, where provided)

Depending on the version, you can request an additional load

compartment fig. 53 located behind the cab.

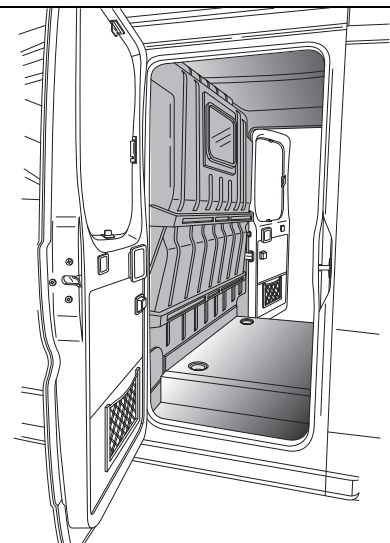

53

F1A0041

## TRAY UNDER THE SEAT

(for versions/markets, where provided)

Under the driver side seat, there is a tray (A) fig. 54, which can be easily removed by sliding it out of the clips on the support base.

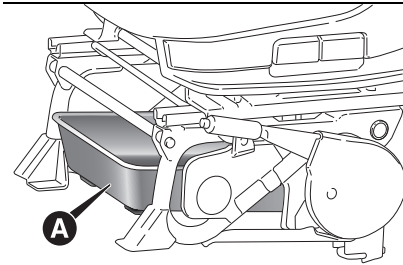

54

F1A0032

## SEAT BASE PLASTIC COVERS

(for versions/markets, where provided)

The front trim (A) fig. 55 can be opened by using the release handle (B) fig. 55 at the top.

This gives access to the tray under the seat (see "Tray under the seat" paragraph).

To make it easier to open the front cover and gain access to the compartment, the seat must be as far back as possible.

To allow removal of the front cover, it must be turned as far forward as possible and withdrawn from the hooks on the lower side by pulling toward the front of the vehicle.

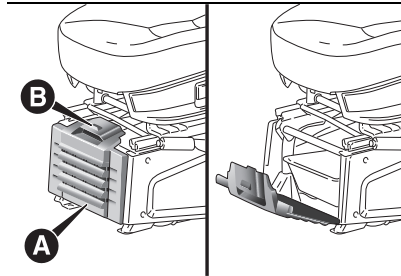

55

F1A0033

## PANORAMA VERSIONS

(for versions/markets, where provided)

### Adjustment of passenger seat reclining backrest

Turn knob (A) fig. 56.

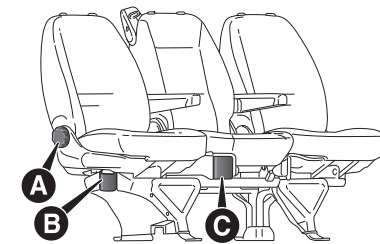

56

F1A0034

### Access to second row seats

To access the second row of seats, operate the lever (B) fig. 56 on the right outside seat in the first row and tilt the backrest forward, accompanying it with your left hand.

When the seat is restored to its normal position, it engages with the retaining device without the need to operate the lever again. On the one-piece Panorama seat in the second row both side seats are fixed.

### Folding middle seat backrest (2<sup>nd</sup> - 3<sup>rd</sup> row)

Lift the lever (C) fig. 56 and tilt the backrest forward.

A hard surface on the back of the middle seat is for use as an armrest and table with cup holders.

Operate the lever to reposition the backrest.

To lower the backrest of the middle seat in the second row, remove the head restraint to make it easier to adjust the backrest of the middle seat in the first row.

## COMBI VERSIONS

(for versions/markets, where provided)

### Easy Entry position

Lift the lever (A) fig. 57 and tilt the backrest forward.



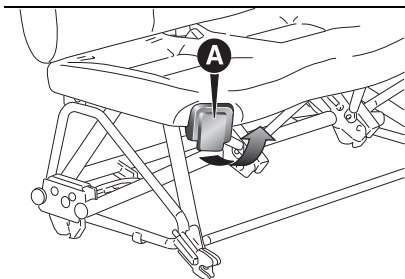

57

F1A0035

### Stacked position

Proceed as follows:

- ❑ remove the head restraints from the Easy Entry position;
- ❑ lift the lever (B) fig. 58, located under the lever (A) fig. 57 with your right hand;
- ❑ turn the backrest by 5° towards the rear area;
- ❑ fold forward the backrest with your left hand.

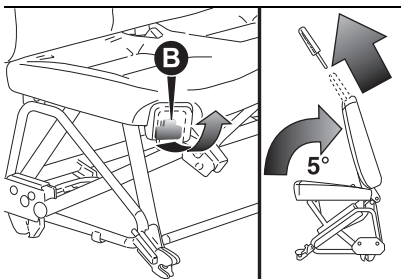

58

F1A0036



### Removing the bench

- ❑ Undo the screws (A) and (B) fig. 59;

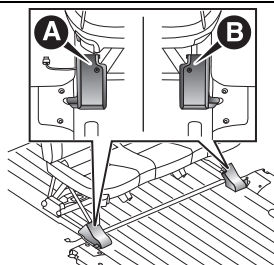

59

F1A0710

- ❑ remove the plastic casing of the benches fig. 60;

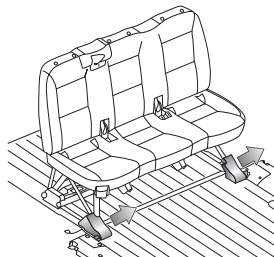

60

F1A0711

- ❑ undo the screws (C) and (D) and remove the heater cover fig. 61;

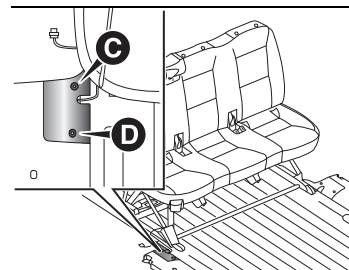

61

F1A0712

- ❑ disconnect the connector fig. 62;

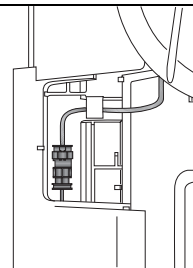

62

F1A0713

- ❑ lift the lever (A), tilt the backrest forward into the Easy Entry position and pull out the head restraints fig. 63;

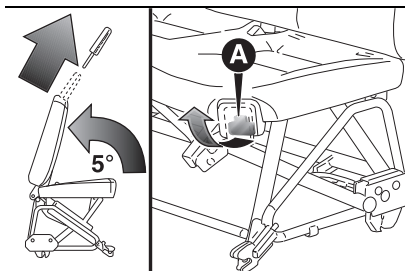

63

F1A0751

□ pull the handle (B) positioned under the cushion and fold down the backrest fig. 64;

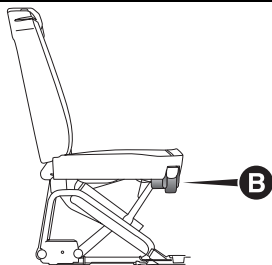

64

F1A0752

□ turn (C) clockwise fig. 65 for rear release;

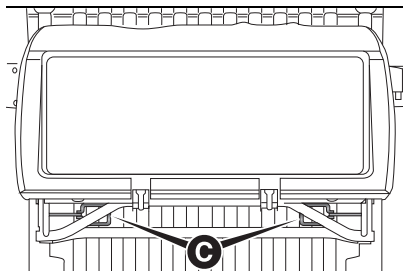

65

F1A0753

□ turn (D) clockwise fig. 66 for front release.

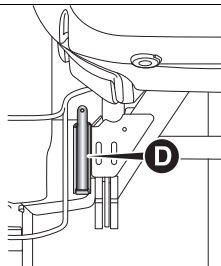

66

F1A0754

### FLEX FLOOR REAR SEAT

(for versions/markets, where provided)  
To release the seat, proceed as follows:

- operate the rear release lever (A) fig. 67 to aid releasing the safety catch underneath it (movement 1);
- pull the black knob (B) fig. 67 (movement 2);

□ lift the lever (A) (movement 3), over the retaining slider (C) fig. 68 (on the side) which holds the system in raised position during the operations.

When the base has been locked, it will be possible to move the seat by accompanying it with both hands to move it forwards or backwards fig. 69.

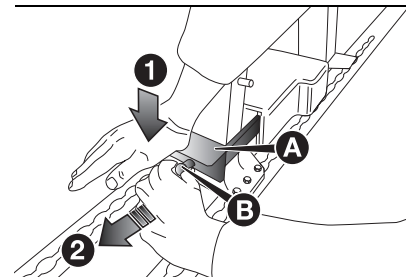

67

F1A0388

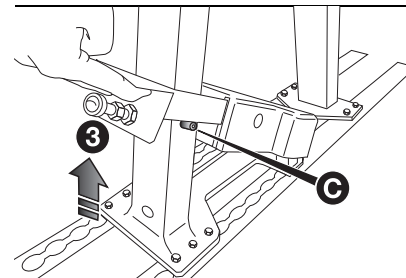

68

F1A0389

It will also be possible to disassemble it by pulling it at the points in which its catches are free with respect to



the holes in the tracks; in that position (easily found by sliding the base a little and simultaneously pulling it out) the seat can easily be removed fig. 70.

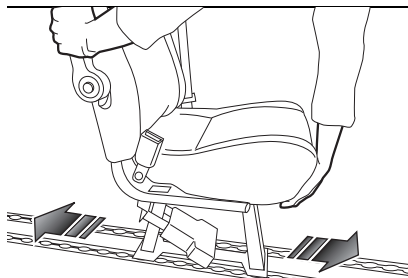

69

F1A0390

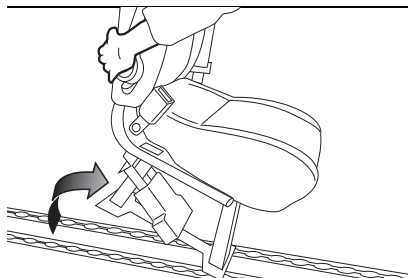

70

F1A0391

After the sliding and removal operations, the seat should be refitted and secured to the rails on the floor before driving, as follows:

- fit the base on the rails;

- push the latch lever downwards fig. 71 with sufficient force, until the system locks.

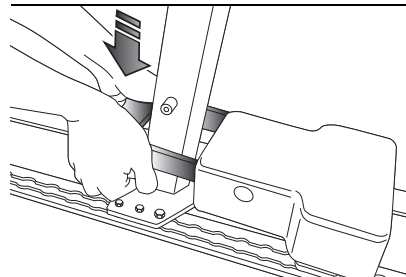

71

F1A0392

**WARNING** The locking system is only secured when the safety clip under the lever locks it horizontally. If this does not happen, check that the seat is in the exact locking position in relation to the rail (moving the seat backwards or forwards a few millimetres until it is properly attached). Once the quick-release base is locked in position, it will be as in the first stage, in other words with the retaining lever perfectly parallel to the floor guaranteeing that the seat is securely fastened in the selected position.

The seat can be turned 180° toward the seat on the opposite side. To turn it, see the "Seat with revolving base" paragraph.

## 4-SEATER BENCH SEAT (Crew Cab Van versions)

(for versions/markets, where provided)  
For specific versions, the vehicle features a 4-seater rear bench seat. The bench has a bottle holder cavity (A) fig. 72.

The seat can be tilted manually to allow access to the load compartment fig. 73.

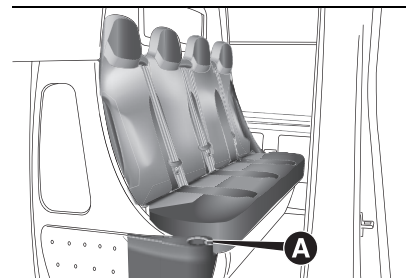

72

F1A0393

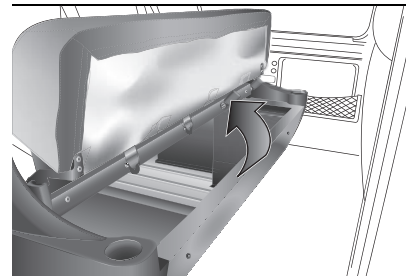

73

F1A0394





## IMPORTANT

- 22)** All adjustments must be made with the vehicle stationary.
- 23)** After releasing the adjustment lever, always check that the seat is locked on the guides by trying to move it back and forth. If it is not locked, the seat may move unexpectedly and make you lose control of the vehicle.
- 24)** For maximum safety, keep the backrest upright, lean back into it and make sure the seat belt fits closely across your chest and pelvis.
- 25)** Before putting on the seat belt, ensure that the armrests are vertical (see the "Seat belts" chapter).
- 26)** Before unfastening the belts and getting out of the vehicle, ensure that the outer armrest (door side) is fully raised.
- 27)** All adjustments must be made with the vehicle stationary. In particular, while turning the seat, take care that it does not interfere with the parking brake lever.
- 28)** Ensure the seat is locked start engine position before starting the engine.
- 29)** Do not place heavy loads on the flap with the vehicle in motion because they could be thrown against the vehicle occupants in the event of sudden braking or impacts, causing severe injury.
- 30)** Do not travel with passengers seated in the 3<sup>rd</sup> row with the 2<sup>nd</sup> row bench folded over. Do not place objects of any type on the backrest of the 2<sup>nd</sup> row bench folded over: in the event of impact or sharp braking they could be thrown against the occupants of the vehicle causing serious injury. For more information, see the

contents of the adhesive plate located under the bench.



## WARNING

- 6)** The fabric upholstery of your vehicle is designed to withstand the normal wear and tear of your vehicle for a long time. You are however recommended to avoid strong and/or continuous scratching with clothing accessories such as metal buckles, studs, Velcro fastenings and the like, as these items cause stress of the cover fabric that could lead to yarn breaking and damage the upholstery.

## STEERING WHEEL

The steering wheel position can be adjusted axially. To carry out the adjustment, proceed as follows:

- release the lever fig. 74 by pulling it towards the steering wheel (position (2));
- adjust the steering wheel;
- release lever by pushing it forwards (position (1)).



31) 32)

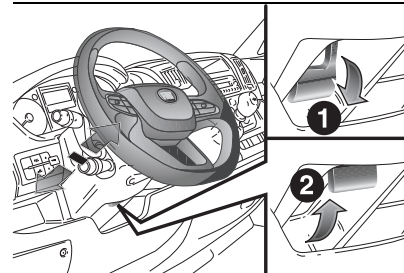

74

F1A0780



## IMPORTANT

- 31)** All adjustments must be carried out only with the vehicle stationary and the engine off.
- 32)** It is absolutely forbidden to carry out any aftermarket operation involving steering system or steering column modifications (e.g. installation of anti-theft device) that could adversely affect performance, invalidate the warranty, cause serious safety problems and also result in the vehicle not meeting type-approval requirements.



## REAR-VIEW MIRRORS

### INTERIOR MIRROR

Lever (A) fig. 75 can be used to move the mirror to two different positions: normal or anti-glare.

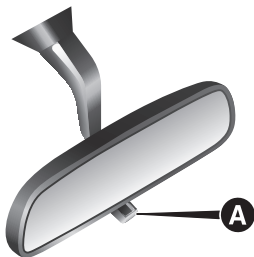

75

F1A0353

### DIGITAL REAR-VIEW MIRROR (DRVM)

(where provided)



The digital rear-view mirror fig. 76 provides a wide, high-definition, unobstructed view of the road behind the vehicle.

To activate the digital rear-view mirror, push the On/Off stalk (A) fig. 76 located at the base of the mirror forwards.

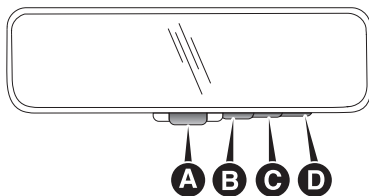

76

F1A0619

- A** On/Off control lever
- B** Menu button
- C** Left scroll button
- D** Right scroll button

Press the button on the side of the lever to access the following options:

- Brightness
- Vertical angle
- Horizontal movement (where provided)

Press the left/right buttons to scroll through the menu options.

When not in use, pull the lever towards yourself to return to the conventional mirror.

The digital rear-view mirror is not functional when travelling under the following conditions:

- driving at night in poor visibility conditions;
- bad weather conditions (e.g. heavy fog, snow).

If the display is difficult to see, clean the camera fig. 77. If snow, ice, mud or other foreign matter obstruct the camera lens, clean it with water and dry it with a soft cloth. Do not cover the camera lens.

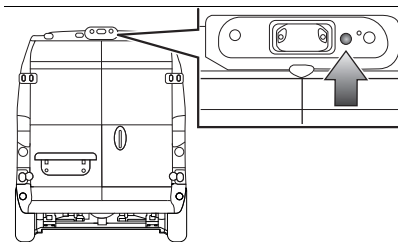

77

F1A0663

### ELECTROCHROMIC REAR-VIEW MIRROR

(where provided)

An automatic electrochromic mirror is fitted on some versions, which automatically modifies its reflecting properties to prevent dazzling the driver fig. 78.

The electrochromic mirror has an ON/OFF button to activate/deactivate the dazzle-prevention electrochromic function.

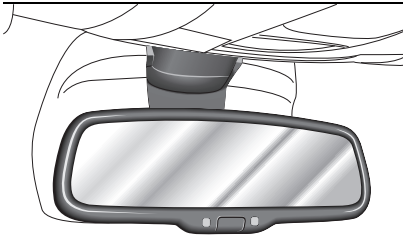

78

JOA0059

When reverse is engaged, the mirror is automatically set for daytime use.

## EXTERIOR MIRRORS

To obtain a better view, adjust the outside mirrors so that they are centred on the adjacent lane with a slight overlap of the view obtained through the inside mirror.

### Mirrors with manual adjustment

To adjust the mirrors, manually operate on each of the two glasses of each mirror.

 34) 35)

### Power Mirrors

The electrical adjustment can only be carried out with the ignition key in the MAR position.

To adjust the mirrors, turn knob (B) fig. 79 to one of the four positions: (1) left mirror, (2) right mirror, (3) left wide angle and (4) right wide angle

(positions (3) and (4) available on short arm external rear-view mirrors, Tempo Libero versions and on all medium and long arm rear-view mirrors).

After rotating the knob (B) on the mirror to be adjusted, move it in the direction shown by the arrows to adjust the selected glass.

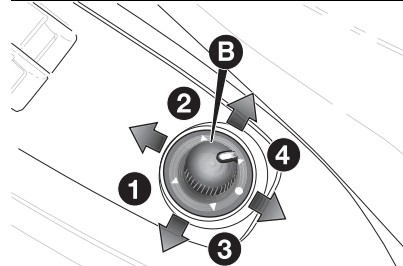

79

F1A0764

### Mirror folding with manual adjustment

When required (for example when the mirror causes difficulty in narrow spaces or during an automatic vehicle wash) it is possible to fold the mirrors manually moving them from position (1) to position (2) fig. 80.

If the mirror has been accidentally rotated forwards (position (3)), for example due to a collision, it must be manually returned to position (1).

The exterior mirrors are hinged and can be folded forwards or backwards

to prevent damage according to these three positions fig. 80:

- 1 Normal
- 2 All backwards
- 3 All forwards

 36)

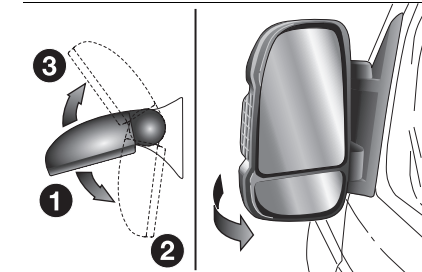

80

F1A0043

### Mirror folding with electrical adjustment

(for versions/markets, where provided)

When required (for example when the mirror causes difficulty in narrow spaces or during an automatic vehicle wash) it is possible to fold the mirrors either electrically or manually moving them from position (1) to position (2) fig. 80.



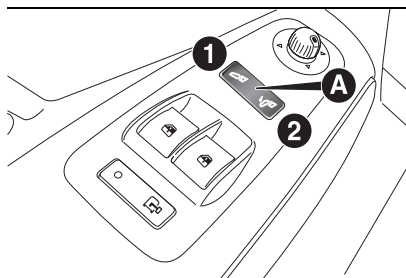

81

F1A0763

### Electric folding

To fold the mirrors electrically, press rocker button (A) fig. 81 in point (2) fig. 81. To bring the mirrors back to open position, press point (1) of the button.

**WARNING** If the mirrors are folded electrically, they should be returned to the open position electrically: do not try to return the mirrors manually to driving position.

### Manual folding

To fold the mirrors manually, move them from position (1) fig. 80 to position (2). If the mirrors have been folded manually, they can be returned to the opening position both manually and electrically.

**WARNING** To take the mirrors electrically to the opening position, press point (2) of the rocker button (A) fig. 81 until you hear an engagement "click", then press again point (1) of the button.

### Folding forwards

The mirrors can be manually folded forwards (position (3) fig. 80) or brought to the opening position (2) again manually if they have been accidentally rotated forwards (for example due to an impact).

If the mirrors have been rotated forwards manually or due to an impact, they can be returned to the opening position both manually and electrically. To take the mirrors electrically to the opening position, press point (2) of the rocker button (A) fig. 81 until you hear an engagement "click", then press again point (1) of the button.

**WARNING** If the mirrors have been manually folded by mistake to position (3) fig. 80, the mirror moves to an intermediate position. In this case, manually rotate the mirror to position (1), then press point (2) of the rocker button (A) fig. 81 to return the mirror to position (2) until a "click" is heard, then

press point (1) of the button to bring it back to position (1).

### Defrosting/demisting

(for versions/markets, where provided) Mirrors are fitted with resistors that will activate when turning the heated rear window on (by pressing button ).

**WARNING** This function is timed and will turn off automatically after several minutes.



### IMPORTANT

**33)** *The digital rear-view mirror provides additional support while driving, improving the view of the road behind. It meets type-approval requirements while driving, but does not provide a full view of the surroundings. It only provides a view of vehicles and objects located at medium and long distances from the vehicle using a camera located at the rear 3rd brake lights. It is recommended not to rely solely on the digital rear-view mirror when performing low-speed manoeuvres (e.g. parking manoeuvres). Only the combination of a digital rear-view mirror and rear camera with dynamic grille (where provided) allows you to have control over what is happening at the back of the vehicle for safer manoeuvres.*

**34)** *As the driver's exterior mirror is curved, it may slightly alter the perception of distance of the reflected image. Further,*

the reflective surface of the lower part of the exterior mirrors is parabolic to increase the field of view. The size of the reflected image is reduced and gives the impression that the reflected object is further away than it is.

**35)** Vehicles and other objects seen through a convex external mirror appear smaller and more distant than they really are. Over-relying on this type of mirror can result in collisions with other vehicles or other objects. It is recommended to use the interior mirror to estimate the size or distance of a vehicle when viewed from a convex side mirror.

**36)** While driving the mirrors must remain in position (1).

## EXTERNAL LIGHTS

The left stalk (A) fig. 82 or fig. 83 or fig. 84 (where provided) controls most external lights.

The external lights turn on also with the ignition key in the MAR position. The instrument panel and the various dashboard controls will come on with the external lights.



82

F1A0851



83

F1A0852



84

F1A0609

## AUTO FUNCTION

### (Dusk sensor)

(where provided)

This is an infrared LED sensor that works in conjunction with the rain sensor and is located on the windscreen. It is able to detect variations in outside lighting based on the light sensitivity set in the display Menu or **Uconnect™** system (where provided).

The higher the sensitivity, the lower the amount of external light needed to automatically switch the external lights on.

### Function activation

Turn the ring of the left stalk to the **AUTO** position fig. 83 or to the  position fig. 84 (where provided).

**WARNING** The function can only be activated with the ignition device at MAR.



### Function deactivation

To deactivate the function, turn the left stalk ring to a position other than **AUTO** or to the  position.

## DIPPED BEAM HEADLIGHTS





With the ignition key in the MAR position, turn the ring (A) fig. 82 or



fig. 83 or fig. 84 (where provided) to position . If the dipped beam headlights are activated, the daytime running lights are switched off and the dipped beam headlights, rear side lights and number plate lights are switched on. The  warning light switches on in the instrument panel.

## DAYTIME RUNNING LIGHTS (DRL) ("Daytime Running Lights")



With the key in the MAR position and the ring turned to  fig. 82 or **AUTO** fig. 83 or  fig. 84 (where provided) the daytime running lights come on automatically; the other lights and interior lighting stays off. If the daytime running lights are deactivated (for versions/market, where provided), no light comes on when the ring is turned to  or **AUTO** or  (where provided). Where provided, if the direction indicators are operated, the daytime running lights switch off automatically. The daytime running lights are temporarily deactivated when the direction indicators are activated. When the direction indicators are deactivated, the daylight running lights are reactivated.

NOTE When the engine is started for the first time with gear in position P (for

versions with automatic transmission) or with the parking brake applied, the daytime running lights stay off. The daylight running lights will come on by removing the parking brake or shifting the gear to a position other than P.

NOTE When the engine is first started, the daylight running lights come on at speeds higher than 10 km/h.

NOTE With the Start&Stop system active, the daylight running lights are always on.

## FOG LIGHTS/REAR FOG LIGHTS







(for versions/markets, where provided)

There are two configurations: the first with fog lights and rear fog, the second with only rear fog. The use of fog lights is governed by the highway code of the country in which you are driving. Comply with legal requirements.

### Cornering lights

The function activates with the main beam headlights switched on with a speed lower than 40 km/h. For wide steering wheel rotation angles or at the switching on the direction indicator, a light will turn on (built in the front fog light) referring to the turning side which will extend the night visibility angle.

To turn on the front/rear fog lights, use button (A) fig. 85 as follows:

-  first press: front fog lights and side lights switch on if the dipped beam headlights are off. Only front fog lights switch on if the dipped beam headlights are on. The  warning light switches on in the instrument panel;
-  second press: turns on the rear fog lights, the  warning light on the instrument panel will turn on;
-  third press: front/rear fog lights and side lights switch off if dipped beam headlights are off. Only front fog lights switch off if the dipped beam headlights are on;
-  fourth press: rear fog lights switch off if dipped beam headlights are on.

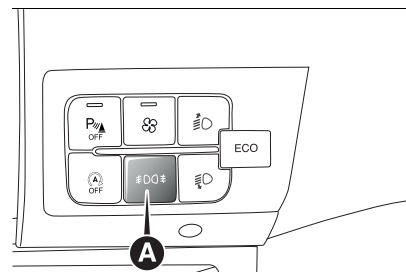



85

F1A0689

## REAR FOG LIGHT

The rear fog light button is located on the left control panel (button (A) fig. 85). With rear fog lights on, the warning light  on the instrument panel will come on at the same time.

## PARKING LIGHTS

These lights can be turned on only with the ignition device at STOP or key extracted by turning the ring on the left stalk first to position  or **AUTO** or  (where provided) and then to positions .

The  warning light switches on in the instrument panel.

Repeat the same operation to switch them off.

An acoustic warning will sound with the parking lights on when the driver's door is opened. The acoustic warning switches off as soon as the driver's door is closed.

## "FOLLOW ME HOME" DEVICE



### Activation

Bring the ignition device to STOP. Within 2 minutes pull the left stalk in main beam headlights flashing mode, each displacement of the stalk will correspond to an increment of 30 seconds of delay on headlights switching off up to a maximum of 210 seconds (equal to 7 flashes).

### Deactivation

Keep the left stalk in main beam headlight flashing mode for a few seconds.

## MAIN BEAM HEADLIGHTS

With ring in position , push the stalk forward toward the dashboard (stable position). The  warning light switches on in the instrument panel. The lights are switched off by pulling the stalk towards the steering wheel.

## AHB (Automatic High Beam) System

(where provided)

The system controls the automatic high beam headlights providing increased forward lighting at night by automating high beam control using of a digital camera mounted on the interior rear-view mirror.

### NOTES

The Auto Dim High Beams control can be turned on or off using the **Uconnect™** system. Refer to the "Settings" paragraph in the "Multimedia" section for further information.

Broken, muddy or obstructed headlights and side lights of vehicles in the field of view of the camera will cause headlights to remain on longer (closer to the vehicle).

To deactivate the automatic function rotate the light switch ring to position .

## Flashing the headlights

To flash, the unstable position is used. Activate by pulling the lever (A) fig. 82 or fig. 83 or fig. 84 (where provided) towards you. With main beam headlights on, the warning light  on the instrument panel will come on at the same time.

## DIRECTION INDICATORS

Move the left stalk fig. 82 or fig. 83 or fig. 84 (where provided) to the (stable) position:

*upwards*: activates the right direction indicator;

*downwards*: activates the left direction indicator.

The  or  warning light respectively will flash on the instrument panel.

The direction indicators switch off automatically when the steering wheel is straightened or when the daytime running lights (DRL) are switched /parking lights are activated.

## "Lane Change" function

To indicate a change of lane with the car moving, move the left lever to the non-stable position for less than half a second.

The direction indicator on the side selected will be activated for 5 flashes and then go out automatically.





## COURTESY LIGHTS

This function, with the ignition device in STOP, allows activating the side lights and the number plate lights for 30, 60 or 90 seconds, whenever the vehicle is unlocked with the key with remote control.

The function can be enabled and the activation time can be set using the display Menu or the **Uconnect™** system.

The function is automatically disabled once the activation time elapses, or when the vehicle doors are locked again, or by turning the ignition device to a position other than STOP.

## LIGHT BEAM DIRECTION

The correct alignment of the headlights is essential for the comfort and safety of the driver and other road users. To ensure the best visibility when travelling with the headlights on, the headlight alignment must be correct. Contact a Fiat Dealership to have the headlights checked and adjusted.

## HEADLIGHT ALIGNMENT CORRECTOR

This device works with the ignition key in the MAR position and the dipped headlights on. The vehicle tilts backwards when it is laden, raising the beam. The beams must therefore be realigned in this case.

## Headlight alignment adjustment

Press the buttons  (A) or  (B) on the control panel fig. 86 to adjust.

The instrument panel display shows the position in relation to the adjustment set.

**WARNING** Check the alignment of the light beams each time the weight of the load transported changes.

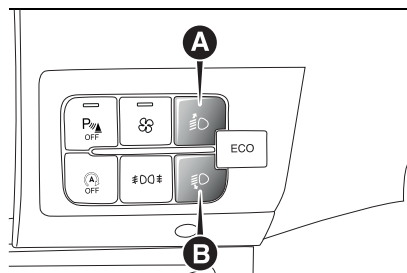

86

F1A0690

## FOG LIGHTS ALIGNMENT

(for versions/markets, where provided)

Contact a Fiat Dealership to have the headlights checked and adjusted.

## ADJUSTING THE HEADLIGHTS WHEN ABROAD

The dipped beam headlights are aligned for operation in the country where the vehicle was originally purchased. When in countries where

you drive on the other side of the road, you need to alter the light beam direction by affixing a specially designed self-adhesive film in order not to dazzle the vehicles travelling in the opposite direction.

This film is provided by Lineaccessori MOPAR and is available at Fiat Dealerships.



## IMPORTANT

**37)** The daytime running lights are an alternative to the dipped headlights while driving during the daytime in countries where it is compulsory to have lights on during the day; where it is not compulsory, the use of daytime running lights is permitted.

**38)** Daytime running lights cannot replace dipped beam headlights while driving at night or through tunnels. The use of daytime running lights is governed by the highway code of the country in which you are driving. Comply with legal requirements.



## CEILING LIGHTS

### COURTESY LIGHTS

The courtesy lights are located between the sun visors, on the upper console.

Each light can be turned on by pressing the corresponding switch fig. 87.

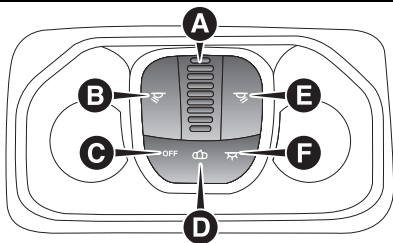

87

F1A0664

**A** Ambient light (where provided)

**B** Left map reading light

**C** OFF/ Left position

**D** Middle position

**E** Right map reading light

**F** ON/ Right position

### Ceiling lights

The interior lights can be set to three positions (OFF/ left position, centre position, ON/ right position). Using the switch (D) on the bottom of the upper console:

□ from the middle position (D) press the switch towards the (F) ON/right position to keep the lights on;

□ from the middle position (D) press the switch towards the (C) OFF/ left position to keep the lights always off.

□ Leaving the switch in the centre position (D) the lights go on or off when the doors are opened or closed.

### Map reading light

The switches on the left and right sides of the upper console control the map reading lights.

Press the right switch (E) to turn the right light on and press again to turn it off.

Press the left switch (B) to turn the left light on and press again to turn it off.

**WARNING** Before getting out of the vehicle, make sure that the switch are in the middle position; when the doors are closed, the lights switch off preventing the battery from running flat.

### Battery save

To extend the life of the vehicle battery, when the engine is turned off and one of the doors is left open for 15 minutes, the interior lights are automatically turned off.

**NOTE** The battery save function will stop when the ignition device is turned to the MAR position.

### LOAD COMPARTMENT REAR COURTESY LIGHT

This is located above the rear door. Press the cover at the point shown in fig. 88 to switch it on.

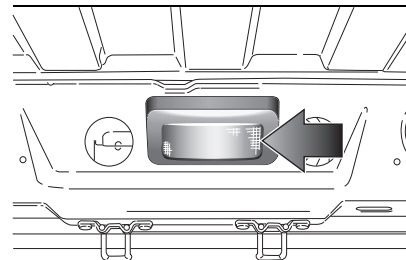

88

F1A0075

### LED CEILING LIGHT IN LOAD COMPARTMENT

It is located on the rood of the load compartment fig. 89.

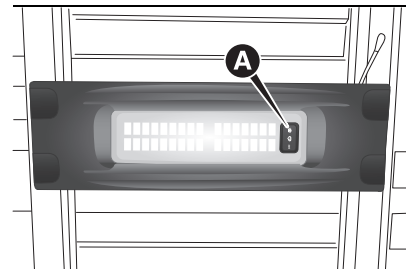



89

F1A0489



The switch (A) can be used to turn it on and off:

□ position : the ceiling light is always on;

□ position : the ceiling light switches on when the front door, side door and rear swing door is opened. It switches off automatically after 30 seconds from when all the doors are closed. It also switches on when the movement of a person is detected in the load compartment, and then switches off automatically after a few seconds from the end of the movement (where provided);

□ OFF position: the ceiling light is always off.

In any case, if the switch is left in on position, the ceiling light switches off automatically 15 minutes after the engine switching off.

After 15 minutes it will not be possible to turn on the ceiling light using the buttons or if any movement is detected.

### LOAD COMPARTMENT SIDE CEILING LIGHT

(for versions/markets, where provided)

Press the cover at the point shown in fig. 90 to switch it on.

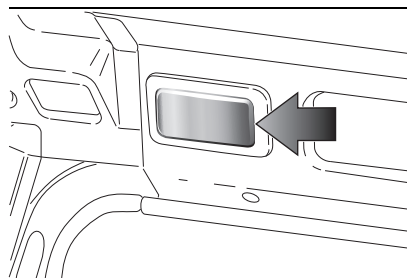

90

F1A0076

### REMOVABLE CEILING LIGHT

(for versions/markets, where provided)

It is used as both a fixed light and a portable electric torch.

When the removable light is connected to its fixed mount fig. 91, the electric torch battery is automatically recharged.

With the vehicle stationary and the ignition key either turned to STOP or removed, the ceiling light is recharged for a maximum of 15 minutes.

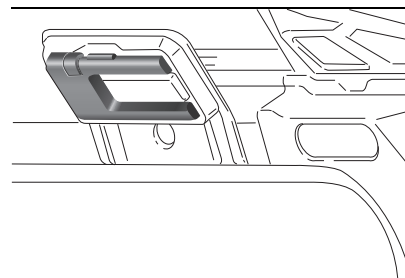

91

F1A0077

### WINDOW WASHING

The right stalk controls screen wiper/washer operation.

This operates only with the ignition device at MAR.

### WINDSCREEN WIPER / WASHER

#### Operation

 39)

 7) 8)

The ring (A) fig. 92 can be set to the following positions:

○ windscreen wiper off

▲ fixed intermittent wipe (slow)

■ speed-dependant intermittent wipe

LO constant slow wipe

HI constant fast wipe

 MIST function



92

F1A0608

### "MIST" function

Move the stalk upwards (unstable position) to activate the MIST function: operation is limited to the time for which the stalk is held in this position. When released, the stalk will return to its default position and the windscreen wiper will be stopped. This function is useful to remove small deposits of dust from the windscreen, or morning dew.

**WARNING** This function does not activate the windscreen washer; windscreen washer fluid will not therefore be sprayed onto the windscreen. To spray windscreen washer fluid onto the windscreen, the washing function must be used. With the ring nut (A) fig. 92 in position O, the windscreen wiper is not activated. In position A, the pause time between the strokes of the windscreen wiper is 10

seconds, independently of the vehicle speed. In position A, the pause time between two strokes is set according to the speed of the vehicle: when the speed increases, the time between two strokes decreases. In position LO or HI, the windscreen wiper moves continuously, i.e. without a pause between two strokes.

### "Smart washing" function

Pull the stalk towards the steering wheel (unstable position) to operate the windscreen washer.

When the stalk is held pulled for longer than half a second, the windscreen wiper is moved with active control. Releasing the stalk will activate three strokes.

Afterwards, if the control is in position O, the washing cycle is concluded by one last stroke after a 6 second pause. If the position is LO or HI, the smart washing function is not carried out.

**WARNING** If the stalk is activated for less than half a second, only the screen washer jet is activated. Do not prolong the activation of the "Smart Washing" function for more than 30 seconds. Do not activate the screen washer control when the reservoir is empty.

## RAIN SENSOR

(where provided)



This device is located behind the interior rear view mirror, in contact with the windscreen glass. It can measure the amount of rain and, consequently, manage the automatic wiping mode of the screen to suit the amount of water on the screen (see the "Automatic Wiping" paragraph).

The sensor will be activated when the ignition device is turned to MAR, and will be deactivated in the STOP position.

The device is able to recognise, and automatically adjust itself in the presence of the following conditions:

- presence of dirt on the surface (e.g. salt, dirt, etc.);
- presence of streaks of water caused by the worn windscreen wiper blades;
- difference between day and night.

**WARNING** Keep the window clean in the sensor area.

## AUTOMATIC WIPING

### Activation



The automatic wiping can be activated by the user by selecting the rain sensor from the display Menu or on the



**Uconnect™** system and rotating the ring nut (A) fig. 92 to position **▲** or **■**.

These will be used to set the rain sensor sensitivity: in position **▲**, the sensor has a lower sensitivity and the wipers will activate when there is a significant amount of water on the screen, while in position **■**, the wipers will be activated when a minimal amount of rain is detected.

The activation of the automatic wiping will be notified by a single stroke. The same stroke will be visible every time the sensor sensitivity is increased, by rotating the ring from position **▲** to position **■**.

The "Smart Washing" function activates the normal washing cycle, after which the automatic wiping function is restored.

If the rain sensor malfunctions, the wiper mode can be modified according to the requirements. In some versions, the failure is indicated by the ! symbol on the instrument panel display. The failure signal remain active during the operation time of the sensor or until the device is reset.

### Inhibition

Moving the ignition device to the STOP position, leaving the ring (A) in fig. 92 in position **▲** or **■**, when the vehicle is next started (ignition device at MAR),

no wiping cycle occurs for system protection reasons.

This temporary inhibition prevents unwanted activation of the wipers when the vehicle is started (i.e. when the windscreen is being washed by hand or the wipers are stuck to the windscreen by ice).

It is possible to reactivate the automatic wiping mode in three ways:

- by turning the ring to the **○** position and then returning it to the **▲** or **■** position;
- by moving the stalk upwards to the MIST  position.
- upon exceeding the 5 km/h speed and the sensor detects rain.

When the windscreen wiper is reactivated using any of the manoeuvres described above, reactivation is indicated by a single stroke of the windscreen wipers, regardless of the condition of the windscreen.

### Deactivation

To deselect automatic wiping, go to the display Menu of the instrument panel or the **Uconnect™** system or by turn the ring (A) of fig. 92 to a position other than flick (**▲** or **■**).

## HEADLIGHT WASHERS

(for versions/markets, where provided)

They are "retractable", i.e. located inside the front bumper of the vehicle. They are activated when the dipped headlights are on and when the windscreen washer is activated is activated for the fifth time.

**WARNING** Check the correct condition and cleanliness of nozzles at regular intervals.



### IMPORTANT

**39)** *If the window needs to be cleaned, make sure the device is turned off or the key is on STOP.*



### WARNING

**7)** *Never use the screen wiper to remove layers of snow or ice from the windscreen glass. In such conditions, the wiper may be subjected to excessive stress and the motor cut-out switch, which prevents operation for a few seconds, may intervene. If operation is not subsequently restored, even after restarting the vehicle, contact a Fiat Dealership.*

**8)** *Do not operate the screen wiper with the blades lifted from the windscreen glass.*

9) Do not activate the rain sensor when washing the vehicle in an automatic car wash.

10) Make sure the device is switched off if there is ice on the windscreen glass.

## VENTS

### ADJUSTABLE SIDE AND CENTRAL VENTS

The vents (A) are not adjustable.

The sliders located on the fins (B) fig. 93 and (C) fig. 94 can be used to adjust the flow and closing the vents, with extra travel to the left.

**A** Fixed vents for side windows.

**B** Adjustable side vents.

**C** Adjustable central vents.

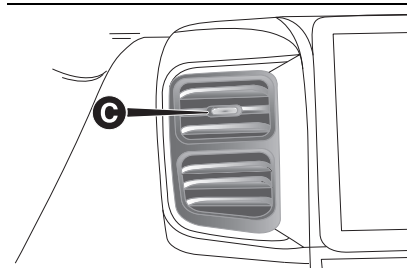
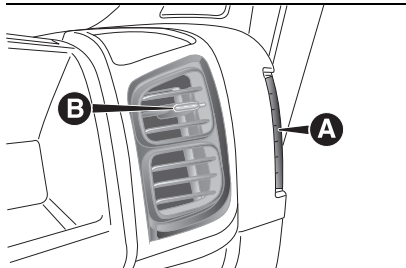

## HEATING AND VENTILATION

---

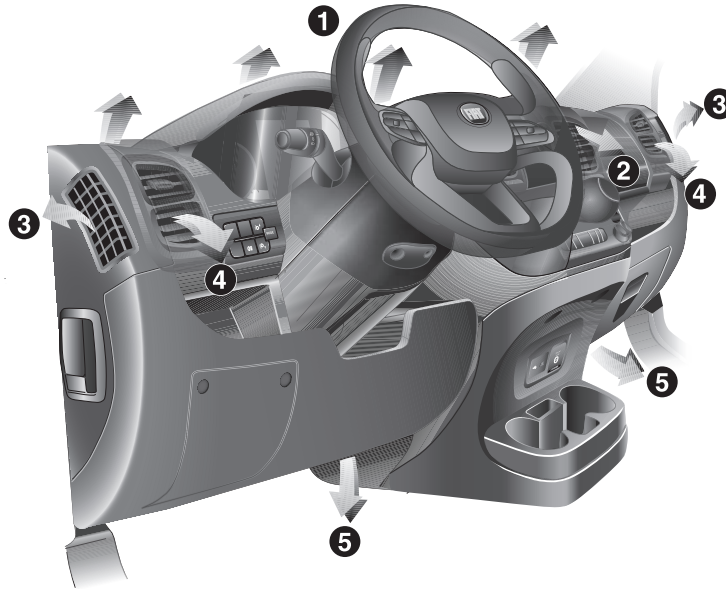

95

F1A0714

1. Upper fixed vent 2. Adjustable central vents 3. Fixed side vents 4. Adjustable side vents 5. Lower diffusers for front seats.

# HEATING AND VENTILATION CONTROLS

(for versions/markets, where provided)

## CONTROLS

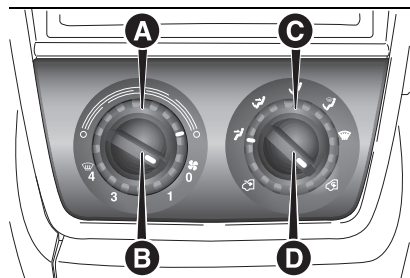

96

F1A0766

### Air temperature adjustment ring A (mixing hot and cold air)

Red section = hot air

Blue section = cold air

### Knob B activates/adjusts the fan

0 = fan off

1-2-3 = fan speed

4  = maximum fan speed

### Air distribution ring C

-  to convey air to the central and side vents;

-  to warm the feet and convey slightly cooler air to the dashboard vents, in intermediate temperature conditions;

-  for heating when the outside temperature is very low: to direct as much air as possible to the feet;

-  to warm the feet and demist the windscreen at the same time;

-  for quick windscreen demisting.



### Air recirculation on/off knob D

Turn the knob (D) to  to activate internal air recirculation.

Turn the knob (D) to  to deactivate internal air recirculation.

## PASSENGER COMPARTMENT VENTILATION

To ventilate the passenger compartment well, proceed as follows:

- turn ring (A) to the blue section;
- turn off internal air recirculation by turning the knob (D) to 
- turn the ring (C) to 
- turn knob (B) to the required speed.

## PASSENGER COMPARTMENT HEATING



Proceed as follows:

- turn ring (A) to the red section;

- turn ring (C) to the required position;
- turn knob (B) to the required speed.

## FAST PASSENGER COMPARTMENT HEATING

For the fast heating of the passenger compartment, proceed as follows:

- turn ring (A) to the red section;
- turn on internal air recirculation by turning the knob (D) to 
- turn the ring (C) to 
- turn knob (B) to 4  (max. fan speed).

Then use the controls to maintain the required comfort conditions and turn the knob (D) to  to turn the air recirculation off and to prevent windows from misting up.



**WARNING** With a cold engine, you have to wait for a few minutes to let the system fluid reach optimum operating temperature.

## FRONT WINDOW FAST DEMISTING/DEFROSTING (WINDSCREEN AND SIDE WINDOWS)

Proceed as follows:

- turn ring (A) to the red section;



- ❑ turn off internal air recirculation by turning the knob (D) to ;
- ❑ turn the ring (C) to ;
- ❑ turn knob (B) to 4  (max. fan speed).

**WARNING** To ensure rapid demisting/defrosting, if there is an additional heater (under the front or rear seat on Panorama and Combi versions) and it is on, turn it off using the button (E) (LED off) located on the control panel fig. 97.

After demisting/defrosting, operate the controls to restore the required comfort conditions.

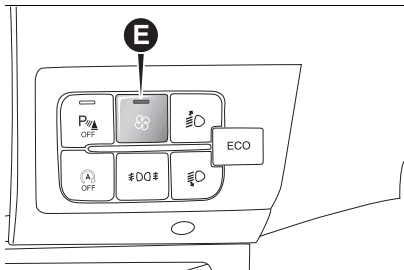



97

F1A0693

### Window demisting

In the event of considerable external moisture and/or rain and/or large differences in temperature inside and outside the passenger compartment,

perform the following preventive window demisting procedure:

- ❑ turn ring (A) to the red section;
- ❑ turn off internal air recirculation by turning the knob (D) to ;
- ❑ turn ring nut (C) to  and consider moving to  if misting does not occur;
- ❑ turn the knob (B) to the 2<sup>nd</sup> speed.

### HEATED REAR WINDOW AND DOOR MIRRORS DEMISTING / DEFROSTING

(for versions/markets, where provided)

Press button (A) fig. 98 to activate this function. The LED on the button will switch on when the function is on.

The function is timed. The key cycle is automatically deactivated for the first time after 10 minutes. At any time after the first activation, the function is deactivated after 5 minutes. Press the (A) button again to turn the function off in advance.

**WARNING** Do not apply stickers on the inside of the heated rear window over the heating filaments to avoid damage.

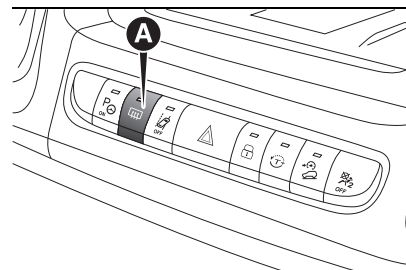

98

F1A0624

### INTERNAL AIR RECIRCULATION ACTIVATION

Turn the knob (D) fig. 96 to .

It is advisable to switch the internal air recirculation on whilst queuing or in tunnels to prevent the introduction of polluted air. Do not use the function for a long time, particularly if there are several passengers on board, to prevent the windows from steaming up.

**WARNING** Internal air recirculation makes it possible to reach the required ("heating" or "cooling") conditions more quickly depending on the mode selected. Do not use the air recirculation function on rainy/cold days as it would considerably increase the possibility of the windows misting inside.



# MANUAL CLIMATE CONTROL SYSTEM

(for versions/markets, where provided)



## CONTROLS

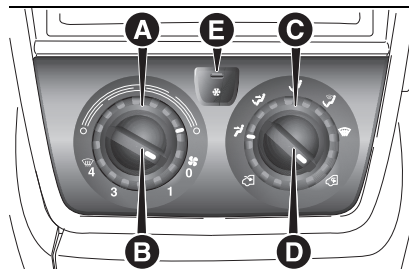

99

F1A0779

### Air temperature adjustment ring A (mixing hot and cold air)

Red section = hot air

Blue section = cold air

### Knob B activates/adjusts the fan

0 = fan off

1-2-3 = fan speed

4 = maximum fan speed

### Air distribution ring C

to convey air to the central and side vents;

to warm the feet and convey slightly cooler air to the dashboard vents, in intermediate temperature conditions;

for heating when the outside temperature is very low: to direct as much air as possible to the feet;

to warm the feet and demist the windscreen at the same time;

for quick windscreen demisting.

### Air recirculation on/off knob D

Turn the knob to to turn internal air recirculation on.

Turn the knob to to turn internal air recirculation off.

### Climate control system on/off button E

Press the button (button LED on) to turn the climate control system on.

Press the button again (button LED off) to turn the climate control system off.

## PASSENGER COMPARTMENT VENTILATION

To ventilate the passenger compartment well, proceed as follows:

turn ring nut A to the blue section;

turn off internal air recirculation by turning the knob (D) to ;

turn the ring (C) to ;

turn knob (B) to the required speed.

## CLIMATE CONTROL SYSTEM (cooling)

For fast cooling of the passenger compartment, proceed as follows:

turn ring (A) to the blue section;

turn on internal air recirculation by turning the knob (D) to ;

turn the ring (C) to ;

press button (E) to turn the climate control system on; the LED on the button (E) will light up;

turn the knob (B) to (4) (fan maximum speed).

### Cooling adjustment

turn the ring (A) to the right to increase the temperature;

turn off internal air recirculation by turning the knob (D) to ;

turn knob (B) to reduce the fan speed.

**WARNING** When air conditioner compressor button (E) is pressed, the function is only activated if at least the first fan speed is selected (knob (B)).

## PASSENGER COMPARTMENT HEATING

Proceed as follows:



turn ring (A) to the red section;



- turn ring (C) to the required position;
- turn knob (B) to the required speed.

### FAST PASSENGER COMPARTMENT HEATING

For the fast heating of the passenger compartment, proceed as follows:

- turn ring (A) to the red section;
- turn on internal air recirculation by turning the knob (D) to ;
- turn the ring (C) to ;
- turn knob (B) to (4)  (fan maximum speed).



Then use the controls to maintain the required comfort conditions and turn the knob (D) to  to turn the air recirculation off and to prevent windows from misting up.

**WARNING** With a cold engine, you have to wait for a few minutes to let the system fluid reach optimum operating temperature.

### FRONT WINDOW FAST DEMISTING/DEFROSTING (WINDSCREEN AND SIDE WINDOWS)

Proceed as follows:

- turn ring (A) to the red section;
- turn knob (B) to (4)  (fan maximum speed).

- turn the ring (C) to ;
- turn off internal air recirculation by turning the knob (D) to ;

**WARNING** To ensure rapid demisting/defrosting, if there is an additional heater/air conditioner (under the front or rear seat on Panorama and Combi versions) and it is on, turn it off using the button (E) fig. 100 (LED off) located on the control panel.

After demisting/defrosting, operate the controls to restore the required comfort conditions.

**WARNING** The climate control system is very useful for speeding up demisting since it dehumidifies the air. Adjust the controls as described above and press button (E) fig. 99 to switch the climate control system on; the LED on the button will light up.

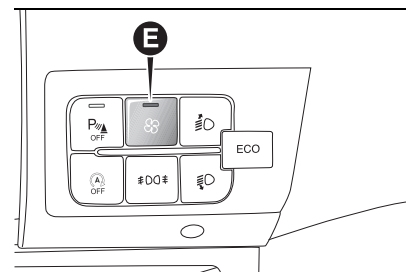



100

F1A0698

### Window demisting

In the event of considerable external moisture and/or rain and/or large differences in temperature inside and outside the passenger compartment, perform the following preventive window demisting procedure:

- turn ring (A) to the red section;
- turn off internal air recirculation by turning the knob (D) to ;
- turn ring nut (C) to  and consider moving to  if misting does not occur;
- turn knob (B) to the 2nd speed.

**WARNING** The climate control system is very useful for preventing the windows from misting up in the presence of high humidity since it dries the air sent into the passenger compartment.

## HEATED REAR WINDOW AND DOOR MIRRORS DEMISTING / DEFROSTING

(for versions/markets, where provided)  
Press button (A) fig. 101 to activate this function: turned on, the LED on the button turns on.

The function is timed. The key cycle is automatically deactivated for the first time after 10 minutes. At any time after the first activation, the function is deactivated after 5 minutes. Press the (A) button again to turn the function off in advance.

**WARNING** Do not apply stickers on the inside of the rear window over the heating filaments to avoid damage.

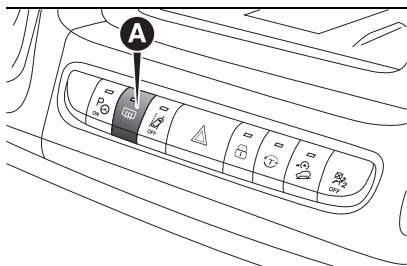

101

F1A0824

## INTERNAL AIR RECIRCULATION ACTIVATION

Turn the knob (D) to .

It is advisable to switch the internal air recirculation on whilst queuing or in tunnels to prevent the introduction of polluted air. Do not use the function for a long time, particularly if there are several passengers on board, to prevent the windows from steaming up.

**WARNING** Internal air recirculation makes it possible to reach the required heating or cooling conditions more quickly depending on the selected operating mode. Do not use the air recirculation function on rainy/cold days as it would considerably increase the possibility of the windows misting inside.

## SYSTEM SERVICING

In winter, the climate control system must be turned on at least once a month for about 10 minutes. Before summer, have the system checked at a Fiat Dealership.



## WARNING

**2)** The air conditioning system uses R134a or R1234yf refrigerant compatible with the regulations in force in the countries where the vehicle is sold. When charging, only use the gas indicated on the dedicated plate in the engine compartment. The use of other coolants affects the efficiency and condition of the system. The lubricant used for the compressor is also strictly linked to the type of cooling gas, please refer to a Fiat Dealership.



## **AUTOMATIC CLIMATE CONTROL SYSTEM**

### CONTROLS ON THE CLIMATE CONTROL FRONT PANEL

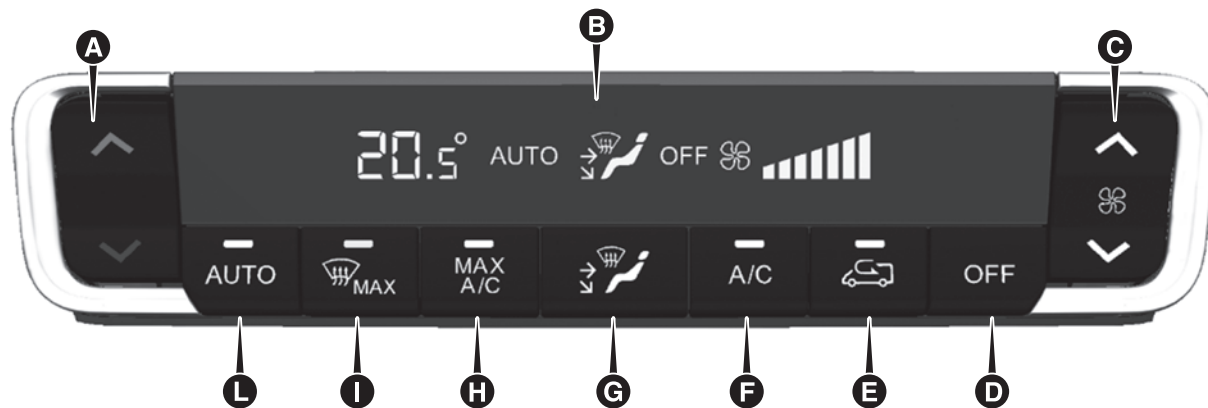

102

F1A0625

A. Required temperature up/down button B. Display C. Ventilation up/down button D. Climate control system off button E. Recirculation button F. Climate control compressor on/off button G. Air supply selection button H. Maximum cooling on/off button I. Windscreen quick defrost button L. Automatic operation on/off button

## CONTROLS ON SYSTEM DISPLAY

(for versions/markets where provided)



103

F1A0573

There are graphic buttons on some **Uconnect™** systems that let you turn on the functions described in this paragraph.

 11)



### WARNING

**11)** To clean the climate control system and the display use a soft, clean, dry, antistatic cloth and make sure that it is switched off during cleaning. Cleaning and polishing products may damage the surface. Do not use alcohol, petrol or their derivatives. Make sure that the cleaning products used contain no alcohol or alcohol derivatives, not even in small quantities.



## Description of the controls

The automatic climate control system maintains comfort inside the passenger compartment and compensates for possible variations in outside weather conditions.

The reference temperature is 22°C for optimal comfort management.

The automatically controlled parameters and functions are:

- air temperature at the driver/front passenger side vents;
- air distribution at the driver/front passenger side vents;
- fan speed (continuous variation of the air flow);
- compressor engagement (for cooling/dehumidifying the air);
- air recirculation.

All these functions can be adjusted manually by operating the system and selecting one or more functions and modifying their parameters.

Manual selections always have higher priority than automatic settings and are stored until the AUTO button is pressed, except for cases in which the system intervenes for safety reasons.

The following operations do not deactivate the AUTO function:

- recirculation on/off;

- compressor on/off, compatibly with environmental conditions;
- variation of set temperature;
- heated rear window on/off (where provided).

The quantity for air introduced into the passenger compartment is independent of the vehicle speed as it is regulated by the electronically controlled fan.

The temperature of the air sent is always automatically controlled according to the temperature set on the display (except for when the system is off or in certain conditions when the compressor is not running).

The system allows the following to be set or adjusted manually:

- air temperature;
- fan speed has 7 positions;
- air distribution;
- compressor enabling;
- rapid defrosting/ demisting function;
- air recirculation;
- heated rear window;
- system deactivation.

## Operating Mode

The climate control system can be activated in different ways: it is advisable to press the AUTO button (L) and press the button (A) fig. 102 to set the desired temperatures.

In this way the system operates completely automatically to adjust the

temperature, quantity and distribution of the air introduced into the passenger compartment. It also manages the air recirculation system and the enabling the air conditioning compressor.

During automatic operation, you can change the set temperatures, activate/deactivate the heated rear window (where provided), activate/deactivate the compressor and the recirculation at any time by using the relevant buttons; the system will automatically change the settings to adjust to the new requirements.

In this way the climate control system will continue to automatically manage all functions except for those that have been manually adjusted. The fan speed is the same in all the zones of the passenger compartment.

## Air temperature adjustment

Press the (A) fig. 102 button:

- press downwards: decrease temperature;
- press upwards: temperature rise.

By repeatedly pressing the (A) button upwards or downwards the HI (maximum air temperature) and LO (minimum air temperature) functions are switched on respectively. To turn these functions off, ask for a numerical air temperature.

## Air distribution selection

Pressing the button (G) fig. 102 on the dashboard or the graphic buttons located on the display of the **Uconnect™** system, you can manually set one of the following air distribution possibilities:

➔ Airflow at central and side dashboard vents to ventilate the chest during the hot season.

➔ Airflow to the front and rear footwell vents. This air distribution setting heats the passenger compartment most quickly, giving a prompt sensation of warmth.

➔ Air flow towards windscreen.



MAX Maximum windscreen defrosting.

You can select the combination of several modes by pressing the buttons in sequence.

In AUTO mode, the climate control system automatically manages the air distribution. The air distribution, when manually set, is displayed on the **Uconnect™** system A/C screen.

## Fan speed adjustment

Press button (C) to increase/decrease the fan speed:

- ▣ press downwards: decrease speed;
- ▣ press upwards: increase speed.

The speed is displayed on the A/C screen of the **Uconnect™** system. A specific fan level can be selected by

pressing the arrows of the dedicated button:

- ▣ **maximum fan speed:** all bars are lit up;
- ▣ **minimum fan speed:** one bar is lit up.

**WARNING** To restore automatic control of the fan speed after a manual adjustment, press the AUTO button.

## AUTO button

When the AUTO button (L) is pressed the climate control system is automatically adjusted in the corresponding zones:

- ▣ quantity and distribution of the air introduced into the passenger compartment;
- ▣ climate control compressor;
- ▣ air recirculation;
- ▣ cancelling any previous manual settings.

If a manual intervention is made on the air distribution or on the fan speed the climate control system is no longer controlling all functions automatically.

To restore automatic system control after one or more manual adjustments, press the AUTO button.

## Air recirculation

The air recirculation can be switched on/off by pressing the button (E) fig. 102.

**WARNING** The engagement of the recirculation system makes it possible to reach the required heating/cooling conditions faster. It is, however, inadvisable to use it on rainy/cold days, or with low external temperatures, as it would considerably increase the possibility of the windows misting up inside rapidly (especially if the climate control system is off).

When the outside temperature is low, recirculation could be switched off (air drawn from the outside) to prevent the windows misting up.

In automatic operation inside air recirculation will be controlled automatically by the system according to outside environmental conditions.

## Climate control compressor

Press button (F) fig. 102 to activate/deactivate the compressor. Switching off the compressor remains stored even after the ignition device has been turned to the STOP position.

To restore automatic control of compressor engagement, press again



button (F) or the AUTO button (L) fig. 102.

**WARNING** With the compressor off, air cannot be introduced to the passenger compartment with a temperature lower than the external temperature. Moreover, under certain environmental conditions, windows could mist up rapidly since the air is not dehumidified.

### Heated rear window demisting/defrosting

Press button (A) fig. 104 to activate heated rear window demisting/defrosting.

Whenever the ignition device switches to the AVV position, the function switches off automatically after approx. 10 minutes the first time it is activated. The following activations have a duration of 5 minutes.

If this function is provided, pressing the button  also activates demisting/defrosting of door mirrors and heated vents (where provided).

**WARNING** Do not apply stickers to the inside of the heated rear window over the heating filaments, to avoid damage that might cause them to stop working properly.

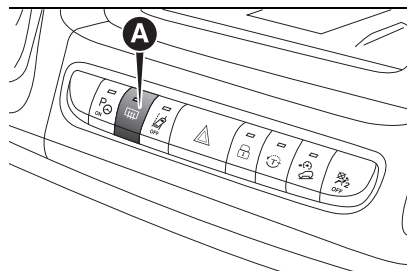

104

F1A0624

### SWITCHING THE CLIMATE CONTROL SYSTEM OFF/BACK ON

#### Switching off the climate control system

Press the OFF button (D) fig. 102.

With climate control system off:

- air recirculation is on, thus isolating the passenger compartment from the outside;
- the compressor is off;
- the fan is off;
- the heated rear window can be activated/deactivated.

The climate control system control unit stores the temperatures set before the system was switched off and restores them when any button of the system is pressed.

### Switching on the climate control system

To switch on the climate control system in fully automatic mode press the AUTO button (L) fig. 102.

### MAX A/C mode

Press and release the Max A/C button (H) fig. 102 to activate the maximum cooling function.

In MAX A/C mode, the fan speed and fan mode can be adjusted according to needs. When other settings are pressed, the MAX A/C switches to the selected setting and is turned off.

### HEATER

The heater activates automatically depending on the environmental conditions and with ignition device in AVV position.

### System maintenance



In winter, the climate control system must be turned on at least once a month for about 10 minutes.

Before summer, have the system checked at a Fiat Dealership.



 **WARNING**

**3)** *The air conditioning system uses R134a or R1234yf refrigerant compatible with the regulations in force in the countries where the vehicle is sold. When charging, only use the gas indicated on the dedicated plate in the engine compartment. The use of other coolants affects the efficiency and condition of the system. The lubricant used for the compressor is also strictly linked to the type of cooling gas, please refer to a Fiat Dealership.*

**ADDITIONAL HEATER**

(for versions/markets, where provided)  
On some versions, an additional heater is also present beneath the driver's seat. The fan for this heater is operated by means of the button (E) located on the control panel fig. 105.

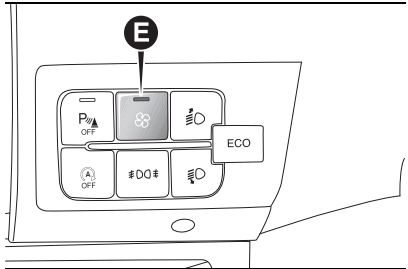

105 F1A0693

**INDEPENDENT ADDITIONAL HEATER**

(for versions/markets, where provided)  
The vehicle is available, on request, with two different independent heaters: one fully automatic, the other which can be programmed.

**AUTOMATIC VERSION**

The additional heater is turned on in automatic mode when the engine is started and the required outside temperature and coolant conditions are present. Deactivation is always automatic.



**WARNING** During periods with low outdoor temperatures when the device cuts in, check that the fuel level is always higher than the reserve level. Otherwise the device could lock and require the assistance of a Fiat Dealership.

**PROGRAMMABLE VERSION**

The additional heater is located on the roof or in the glove compartment of the cab, where provided. It is completely independent of the operation of the engine for:

- heat the passenger compartment with the engine off;
  - defrosting the windows;
  - heat the engine coolant and then the engine itself prior to starting.
- The system consists of:
- a diesel burner for heating the water with an exhaust silencer for the combustion gases;
  - a metering pump connected to the reservoir pipes for supplying the burner;
  - a heat exchanger connected to the engine cooling system pipes;
  - a control unit connected to the passenger compartment heating/ventilation system to allow automatic operation;
  - an electronic control unit for controlling and adjusting the built-in burner;
  - a digital timer fig. 106 for turning the heater on manually or for programming the time it comes on.
- The additional heater (during winter) heats, maintains the temperature of and circulates engine coolant for a set time period in order to ensure optimum engine and passenger compartment conditions at engine start-up.
- The heater can operate automatically when programmed with a digital timer or manually by pressing the 'immediate heating' button on the timer.



After heater activation, whether programmed or manually, the electronic control unit operates the coolant pump and turns on the burner in accordance with pre-set, controlled procedures.

The circulation pump output is also controlled by the electronic control unit in order to minimise the initial heating time.

When the system operates, the control unit turns on the passenger compartment heater unit fan at the second speed.

The thermal power of the boiler is regulated automatically by the electronic control unit depending on the temperature of the engine coolant. The heater can turn off spontaneously due to misfiring after start-up or because the flame goes out during operation. In this case, carry out the turning off procedure and try to turn the heater back on. If it still does not work, consult a Fiat Dealership.

**WARNING** The heater is equipped with a thermal limiter that cuts off combustion in the case of overheating due to insufficient coolant/coolant leaks. In this case, after repairing the fault in the cooling system and/or topping up the fluid, press the program

selection button before turning the heater back on.

### Activation of the heating system

When an automatic climate control system is present, the control unit sets the air temperature and distribution when the heater is turned on from the park position. When a manual heater/climate control is present, to obtain maximum heater efficiency, check that the passenger compartment heating/ventilation temperature adjustment knob is in the 'hot air' position.

To prioritise passenger compartment pre-heating, set the air distribution knob to the  position.

To favour windscreen demisting, set the air distribution knob to the  position.

To obtain both functions, set the air distribution knob to the  position.

### OVERVIEW

Control panel fig. 106 and menu structure:

- (1) Menu item name
- (2) Menu symbol
- (3) Activated preset time
- (4) Time
- (5) Quick start button with status indicator

(6) Control button



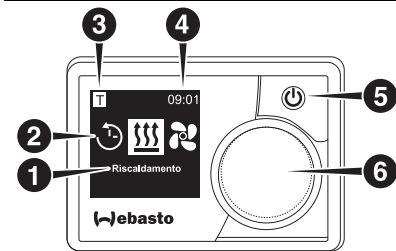

The following menu items are available in the main menu: timer, heating and settings.



106

F1A0667

### Symbols

| Symbol  | Description              |
|---|--------------------------|
|  | Timer menu (preset time) |
|  | Heating menu             |
|  | Update program time      |
|  | Settings Menu            |

| Symbol   | Description |
|--|-------------|
|  | Time on     |

## Buttons and controls

| Button  | Controls and functions                   |
|---|--|
|  | Quick start button with status indicator |
| Control button rotation (knob/button)   | Function selection                       |
| Control button operation (knob/button)  | Confirming the function selected         |

## "Back" function

Exit the selected menu with the "Back" function. The settings are saved and the previous menu level is displayed.

## State indicator

The status of the heater is indicated by the colour of the light on the quick start button.



| Status       | LED lighting |
|--------------|--------------|
| Heating mode | GREEN steady |

| Status  | LED lighting   |
|---|----------------|
| Heater off - control panel on                             | WHITE steady   |
| Error - Heating mode not available                        | RED flashing   |
| Pre-programmed heating mode - Control panel in idle state | GREEN flashing |

The control panel goes into sleep mode (display and LEDs go out) if no actions are made on the control panel for 60 second and the heater is off.

## Passive mode display

If the heater is activated by another Webasto control panel (e.g. Telestart or ThermoCall), the control panel is reactivated from its idle state and the operating mode selected by the other control panel is shown on the display. The display depends on the connected heater. The display depends on the connected heater.

| Display  | Working mode  |
|--|---|
|  | Heating. Press the quick start button  to deactivate passive mode. The heater is switched off. |

## Information display

The following information about the connected heater and the control panel is shown on the start-up display:

- name of the control panel;
- name of the connected heater;
- software version of the connected control panel;
- hardware version of the connected control panel.

The main menu is displayed after 1.5 s.

## HEATING MODE

- Select the "Heating" menu item in the main menu.
- Press the control button. The operating time flashes in the display.
- Turn the control button to select the operating time "Now".

The maximum operating time can be selected and activated by turning the control button clockwise.

- Then press the control button to confirm the selection.

The operating time is set in "Minute" and "Hour".

- Heating mode is started. The "Heating" menu item and the preset remaining time appear in the display. The quick start button lights up green.

## SWITCHING ON THE HEATER WITH THE QUICK START BUTTON

The "Quick start" can be used to activate the heating function by simply



pressing the  button. The operating mode can be changed according to your wishes.

### Quick start of the water heater

The quick start button is programmed for heating.

Press the quick start button .

The heating is started. The "Heating" menu item and the preset remaining time appear in the display. The quick start button lights up green.

### Temperature adjustment during heating operation

- The heater is running.
- Turn the control button, select the required temperature.
- Press the control button within 5 seconds to confirm your selection.

### Adjusting the heating level during operation

- Heater with selectable heating levels.
- The heater is running.
- Press the control button to toggle between temperature selection and heating level selection.
- Press the arrow button to select the required heating level.
- Press the control button within 5 seconds to confirm your selection.

### Remaining time adjustment

A longer operating time must be set is a longer residual time is preferred. No

further changes can be made after a minimum operating time of 10 minutes. An extension is only possible after switching off and on again.

### Remaining time of the water heater

- The heater is running.
- Turn the control button to select the operating time "Minutes".
- Then press the control button to confirm the selection. The heating is started. The "Heating" menu item and the preset remaining time appear in the display. The quick start button lights up green.

### TURNING OFF

- The heater is running.
- Press the quick start button. The lighting of the quick start button changes from green (in heating mode) to white.

### TIMER PROGRAMMING (PRESET TIME)

This function is only available with the MultiControl control panel. Pre-selection times can be scheduled up to 7 days in advance. The heater switches on automatically at the programmed time. You can store up to 3 preset times per day and up to 21 preset times in total. The number of active timers available may vary according to the MultiControl variant used and the type of application (e.g. car, truck,

boat, etc.). A maximum number of 21 active timers can be available.

### Timer: preset time setting

- Current time and day of the week are set.
- The heater is off.
- The "Timer" menu item has been selected in the main menu.
- Press the control button. "Update programmed time" appears in the display (if no timer has been saved yet).
- Press the control button to add a new timer.
- Turn the control button to select the "Day of the week".
- Then press the control button to confirm the selection.
- Turn the control button to select the "Hour" power on time.
- Then press the control button to confirm the selection.
- The "Minute" start time is set as the "Hour" start time.
- Turn the control button to select the "Hour" stop time.
- Then press the control button to confirm the selection.
- The "Minute" stop time is set as the "Hour" stop time.

### Timer: Heating mode setting

All heaters:

- Then press the control button to confirm the selection. The timer is

saved and shown on the display (temperature indicator for air heaters only).

- ❑ Press the button to activate/deactivate the timer. "Activate" appears on the display.
- ❑ Then press the control button to confirm the activation. An activated preset time is marked with a white bar.
- ❑ A "T" symbol appears in the main menu. The quick start button flashes green if a timer is active for the heating function.

### Activating, deactivating, adjusting or deleting the timer

- ❑ Press the control button. Saved timers are shown on the display. The timers are placed in chronological order by day/time. The next active timer is displayed first. (Fan speed indicator for air heaters only).
- ❑ Turn the control button to select the timer.
- ❑ Then press the control button to confirm the selection.
- ❑ Turn the control button to select one of the options ("On", "Off", "Fit", "Delete").

### Clear all timers

- ❑ The "Timer" symbol is selected in the main menu.

- ❑ Press the control button. Saved timers are shown on the display. (Fan speed indicator for air heaters only)
- ❑ Turn the control button anticlockwise until "Clear all" appears in the display.
- ❑ Then press the control button to confirm the selection. "OK" will appear on the display
- ❑ Then press the control button to confirm the selection. All programmed timers have been cleared. The main menu appears on the display.

### Setting the day of the week

The "Settings" menu item has been selected.

- ❑ Turn the control button to select the "Day of the week".
- ❑ Then press the control button to confirm the selection.
- ❑ Turn the control button to select the required "Day of the week".
- ❑ Then press the control button to confirm the selection.

### Set time

The "Settings" menu item has been selected.

- ❑ Turn the control button to select the "Time" menu item.
- ❑ Then press the control button to confirm the selection.
- ❑ Turn the control button to select the desired format (12/24 hours).

- ❑ Then press the control button to confirm the selection. The time flashes on the display.
- ❑ Turn the control button to select "Hour".
- ❑ Then press the control button to confirm the selection. The "Minute" time flashes. The "Minute" time is set as the "Hour" time.

### Language setting

The "Settings" menu item has been selected.

- ❑ Turn the control button to select the "Language" menu item.
- ❑ Then press the control button to confirm the selection.
- ❑ Turn the control button to select the required language (e.g. "Italian").
- ❑ Then press the control button to confirm the selection.

### Setting the temperature unit

The "Settings" menu item has been selected.

- ❑ Turn the control button to select the "Temperature unit" menu item.
- ❑ Press the control button to select the unit. This setting is acquired without confirmation.

### Brightness setting

The brightness of the monitor is adapted via the vehicle signal according to the installation.



The "Settings" menu item has been selected.

- ❑ Turn the control button to select the "Brightness" menu item.
- ❑ Then press the control button to confirm the selection.
- ❑ Turn the control button to select the required value.
- ❑ The set value flashes.
- ❑ Then press the control button to confirm the selection.

### Display deactivation setting

The "Settings" menu item has been selected.

- ❑ Turn the control button to select the "Screen Timeout" menu item.
- ❑ Then press the control button to confirm the selection.
- ❑ Turn the control button to select the required time or "Auto".
- ❑ Then press the control button to confirm the selection.

The display is not deactivated during active heating if the "Auto" option is selected. The display switches off after 10 seconds when set to "Auto" if no heater is active.

### Day/night lighting setting

You can choose between daily and night lighting for the display. If the "Off" option is selected, the general brightness setting is activated without any distinction between day and night.

The "Settings" menu item has been selected.

- ❑ Turn the control button to select the "Day/Night" menu item.
- ❑ Then press the control button to confirm the selection.
- ❑ The "Off" selection is preset.
- ❑ Turn the control button to set the values for Start of Day, End of Day, Brightness (Day), Brightness (Night).
- ❑ The display shows the pre-selected time for Day.
- ❑ Then press the control button to confirm the selection.
- ❑ The display flashes "Time" for "Start of day".
- ❑ Turn the control button to select the required "Time" of "Start of Day".
- ❑ Then press the control button to confirm the selection. The "Minute" time for "Start of day" flashes on the display.
- ❑ "Minute" of "Start of day" is set as "Hour" of "Start of day".
- ❑ Turn the control button to select the required "Time" for "End of Day".
- ❑ Then press the control button to confirm the selection. The "Minute" time for "End of day" flashes on the display.
- ❑ "Minute" of "End of day" is set as "Hour" of "Start of day".
- ❑ The display shows the "Day" brightness level.

- ❑ Turn the control button to select the required "Day" heating level.
- ❑ Then press the control button to confirm the selection. The "Night" brightness level appears on the display.
- ❑ Turn the control button to select the required "Night" brightness level.
- ❑ Then press the control button to confirm the selection.
- ❑ The "Day/night" symbol appears on the display. The selected values have been saved.

### Calling up system information

The system information contains data on the software and hardware version of the control panel as well as the designation of the connected heater. The "Settings" menu item has been selected.

- ❑ Turn the control button to select the "System Information" menu item.
- ❑ Then press the control button to confirm the selection. The name of the heater appears on the display.
- ❑ Turn the control button to toggle between the heater name and the control panel information (control panel name, software and hardware version).

### Recalling saved error message

Error messages (codes) related to the heater and all other connected components in case of malfunctions are saved and displayed here. Current

error messages are also marked with a "!". Error messages must be acknowledged as soon as they appear by pressing the control button. The main menu is only displayed again after confirmation.

The "Settings" menu item has been selected.

- ❑ Turn the control button to select the "Error Message" menu item.
- ❑ Then press the control button to confirm the selection. The error message (or messages) appears on the display. "OK" appears on the display if there is no error message. In case of repeated error messages, all messages can be called up by turning the control button.
- ❑ Press the control button to go back to the menu item.

### Reset

Reset restores all the basic configuration settings (basic settings by the technician) except for the day of the week and the time.

The "Settings" menu item has been selected.

- ❑ Turn the control button to select the "Reset" menu item.
- ❑ Then press the control button to confirm the selection. "OK" will appear on the display

- ❑ Then press the control button to confirm the selection. A reboot is performed. Your personal settings are cleared. This process cannot be retroactive.

### CLEANING

Use only a soft, lint-free cloth to clean the control panel. No moisture may enter the housing. Do not use glass cleaners, household cleaners, sprays, solvents, alcohol-based cleaners or abrasive products for cleaning.

### ERROR MESSAGE

Heater error messages are displayed as "F" or "H" and must be taken from the respective heater description. Error messages on the control panel are displayed with a "T".

An error message appears on the display.

- ❑ Press the control button to confirm the error message.
  - The error message is stored in the error memory.
  - If no confirmation is received, the error message is displayed again (e.g. when restarting or exiting standby mode).

### Error codes

If an error message appears on the display, contact Customer Service.

**WARNING:** Maintenance and repair work on heaters must only be carried out by trained qualified personnel.

### Excerpt of control panel error messages

**T84** - Low voltage (power supply is low). Charge the battery or check the electrical system of the vehicle.

**Te4** - Fault status LED. Contact Support/Customer Service.

**Teb** - Time error. In case of a power failure longer than 8 minutes: re-enter date/time. If the error occurs without voltage interruption: contact the Service/Customer Service department.

**T12** - Faulty W-Bus communication. Wrong heater selected. Follow the procedure in the installation instructions. Contact Support/Customer Service (if necessary).

### SCRAPPING

The control panel must not be disposed of with household waste. Comply with regional regulations regarding the disposal of electronic products.

### ASSISTANCE AND CUSTOMER SERVICE

Do you have technical questions or a problem with your device? Do you have



technical questions or a problem with your device?

## MAINTENANCE

Have the additional heater checked regularly at a Fiat Dealership (and always at the start of every winter). This will guarantee safe and economic operation of the heater as well as a long duration.

## ADDITIONAL REAR HEATING (Panorama and Combi)

(for versions/markets, where provided)

Panorama and Combi versions are equipped with a main heating system plus an additional system (as an option) with a control on the roof lining above the second row of seats fig. 107.

For it to operate, it must be enabled using the button (E) fig. 108 on the control panel.

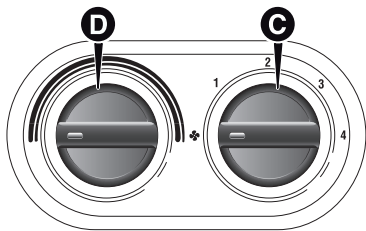

107

F1A0082

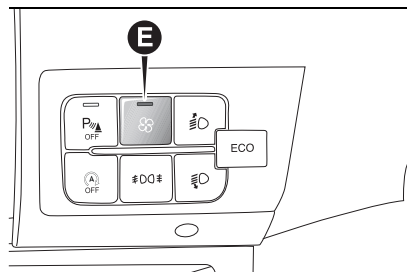

108

F1A0693

Turn the knob (D) to the maximum cold position (knob at blue sector); air at ambient temperature will come out of the rear footwell vents (located under the seats in the 2<sup>nd</sup> - 3<sup>rd</sup> row for Panorama versions and the grille on the left wheel arch side for Combi versions);

Turn the knob (D) to the maximum heating position (knob at red sector); warm air will emerge (with the engine warmed up), from the rear footwell outlets (located under the seats in the 2<sup>nd</sup> - 3<sup>rd</sup> for Panorama versions and the grille on the left wheel arch side for Combi versions).

## ADDITIONAL REAR CLIMATE CONTROL (Panorama and Combi)

(for versions/markets, where provided)

Panorama and Combi versions are equipped with a main heating/air

conditioning system plus an additional system (as an option) with a control on the roof lining above the second row of seats fig. 107. Button (E) fig. 110 on the control panel must be enabled for operation; the air conditioning only works if the main climate control system is on.

□ When the knob (D) is placed in the fully cold position (control in blue sector) cold air comes out the vents in the ceiling.

□ Turn the knob (D) to the maximum heating position (knob at red sector); warm air will emerge (with the engine warmed up), from the rear footwell outlets (located under the seats in the 2<sup>nd</sup> - 3<sup>rd</sup> row for Panorama versions and the grille on the left wheel arch side for Combi versions).

□ If the selector knob (D) is placed in the intermediate positions, the air will be distributed between the vents in the ceiling and the rear footwell vents, varying the temperature.

**WARNING** If the compressor on the main climate control system control is turned on (operation of button (E)), even if the additional climate control system fan is in position (0), the 1<sup>st</sup> speed will automatically be activated to prevent ice formation, with possible damage to the component.





## IMPORTANT

**40)** The heater burns fuel in the same way as the engine, though to a lesser extent. To prevent poisoning and asphyxiation, the supplementary heater must never be turned on, not even for short periods, in closed environments such as a garage or workshops without extraction fans for the exhaust gases.

## REAR AIR CLIMATE CONTROL SYSTEM FOR PASSENGER TRANSPORT

### ADDITIONAL REAR HEATING (Panorama and Combi)

(for versions/markets, where provided) Panorama and Combi versions are equipped with a main heating system plus an additional system (as an option) with a control on the roof lining above the second row of seats fig. 109. For it to operate, it must be enabled using the button (E) fig. 110 on the control panel.

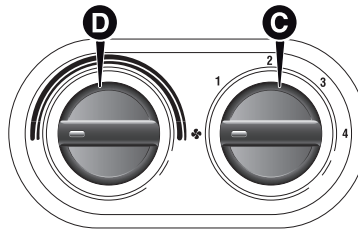

109

F1A0062

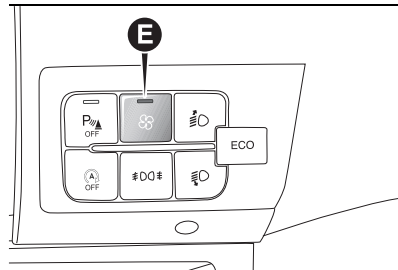

110

F1A0693

Turn the knob (D) to the maximum cold position (knob at blue sector); air at ambient temperature will come out of the rear footwell vents (located under the seats in the 2<sup>nd</sup> -3<sup>rd</sup> row for Panorama versions and the grille on the left wheel arch side for Combi versions);

Turn the knob (D) to the maximum heating position (knob at red sector); warm air will emerge (with the engine warmed up), from the rear footwell

outlets (located under the seat in the 2<sup>nd</sup> and 3<sup>rd</sup> row for Panorama versions and the grille on the left wheel arch side for Combi versions).

### ADDITIONAL REAR CLIMATE CONTROL (Panorama and Combi)

(for versions/markets, where provided) Panorama and Combi versions are equipped with a main heating/air conditioning system plus an additional system (as an option) with a control on the roof lining above the second row of seats fig. 109. Button (E) fig. 110 on the control panel must be enabled for operation; the air conditioning only works if the main climate control system is on.

When the knob (D) is placed in the fully cold position (control in blue sector) cold air comes out the vents in the ceiling.

Turn the knob (D) to the maximum heating position (knob at red sector); warm air will emerge (with the engine warmed up), from the rear footwell outlets (located under the seats in the 2<sup>nd</sup> and 3<sup>rd</sup> row for Panorama versions and the grille on the left wheel arch side for Combi versions).

If the selector knob (D) is placed in the intermediate positions, the air will be distributed between the vents in



the ceiling and the rear footwell vents, varying the temperature.

**WARNING** If the compressor on the main climate control system control is turned on (operation of button E), even if the additional climate control system fan is in position 0, the 1st speed will automatically be activated to prevent ice formation, with possible damage to the component.

## **ELECTRIC WINDOWS**

Switches fig. 111 on the inner armrest of the driver's door control the following with the ignition key in the MAR position:

- (A): left front window opening/closing;
- (B): right front window opening/closing.

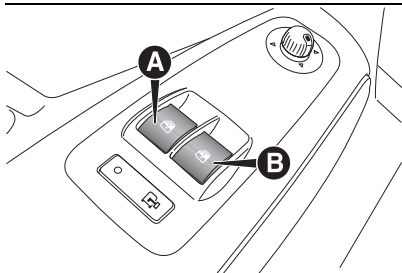

111

F1A0782

## **Continuous automatic operation**

The driver's side front window allows continuous automatic operation in both directions: opening and closing. The passenger-side window only allows continuous automatic operation for opening.

Keep one of the buttons pressed for longer than half a second to operate the automatic continuous window operation function. The window stops when it reaches the end of travel position, or when the button is pressed again.

**WARNING** With the ignition key in the STOP position or extracted, the electric windows remain activated for about 3 minutes and are deactivated immediately when one of the doors is opened.

## **Front passenger side door**

A dedicated switch for operating the window is located on the inner armrest of the passenger side front door.



41)



## **IMPORTANT**

**41)** *Improper use of the electric windows can be dangerous. Before and during operation, always check that nobody is exposed to the risk of being injured either directly by the moving window or through objects getting caught or hit by it. When leaving the vehicle, always remove the key from the ignition switch to avoid the risk of injury to anyone remaining in the vehicle due to accidental operation of the electric windows.*

## **BONNET**

### **OPENING**

Proceed as follows:

- open the driver's door to gain access to the bonnet release;
- pull the lever fig. 112 in the direction indicated by the arrow;
- lift lever (A) fig. 113 as shown in the figure;
- lift the bonnet and, at the same time, release the supporting rod fig. 114 from its locking device (D), then insert the end of the rod (C) fig. 115 into housing (E) in the bonnet.

**WARNING** Before opening the bonnet, check that windscreen wiper arms are not lifted from the windscreen.

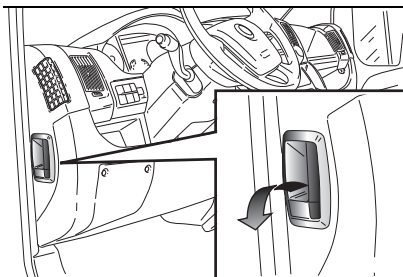

112

F1A0126

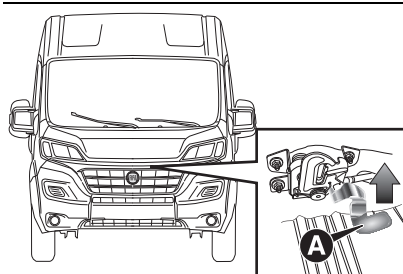

113

F1A0339

## CLOSING

Proceed as follows:

- hold the bonnet up with one hand and with the other remove rod (C) fig. 115 from recess (E) and fit it back into its catch (D) fig. 114;
- lower the bonnet to approximately 20 centimetres from the engine compartment and let it drop. Make sure that the bonnet is completely closed and not only fastened by the

locking device by trying to open it. If it is not perfectly closed, do not try to press the bonnet down but open it and repeat the procedure.

**WARNING** Always check that the bonnet is closed correctly to prevent it from opening while the vehicle is travelling.

 42) 43) 44) 45) 46)

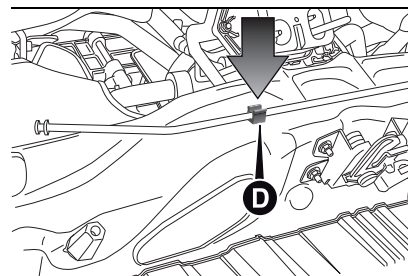

114

F1A0349

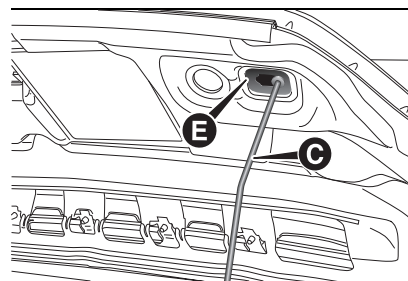

115

F1A0129



## IMPORTANT

**42)** Be very careful not to allow scarves, neck ties and other loose articles of clothing from touching, even accidentally, any moving parts. This may cause the clothing to be pulled into the part, resulting in serious risk to the wearer.

**43)** For safety reasons, the bonnet must always be properly closed while driving. Therefore, make sure that the bonnet is properly closed and that the lock is engaged. If you discover that the bonnet is not perfectly closed while driving, stop immediately and close the bonnet in the correct manner.

**44)** The bonnet may drop suddenly if the supporting rod is not positioned correctly.

**45)** Perform these operations only when the vehicle is stationary.

**46)** Use both hands to lift the bonnet. Before lifting, check that the windscreen wiper arms are not raised from the windscreen, that the vehicle is stationary and that the parking brake is engaged.



## HEAD RESTRAINTS

### FRONT HEAD RESTRAINTS

On certain versions the head restraints are adjustable in height and they lock automatically in the required position.



47

#### Adjustment

**Upwards adjustment:** raise the head restraint until it clicks into place.

**Downward adjustment:** press button (A) fig. 116 and lower the head restraint.

To extract the rear head restraints press buttons (A) and (B) fig. 116 located at the side of the two supports simultaneously and lift them out upwards.

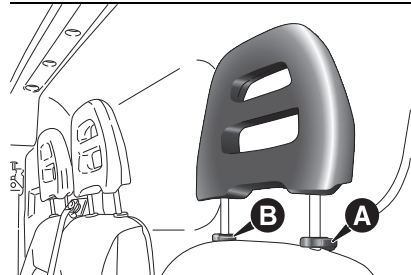

116

F1A0039



### IMPORTANT

**47)** All adjustments must be carried out only with the vehicle stationary and the engine off. Head restraints must be adjusted so that the head, rather than the neck, rests on them. Only in this case they can protect your head correctly. To maximise the protective action provided by the head restraint, adjust the seat backrest so that your trunk is upright and keep your head as close to the head restraint as possible.

## INTERIOR FITTINGS

### UPPER STORAGE COMPARTMENT - REFRIGERATED COMPARTMENT

(for versions/markets, where provided)

To use, lift the inspection flap as shown in fig. 117.

With a climate control system, the compartment, equipped with a bottle holder, may be cooled/heated by means of an outlet connected to the air conditioning system.

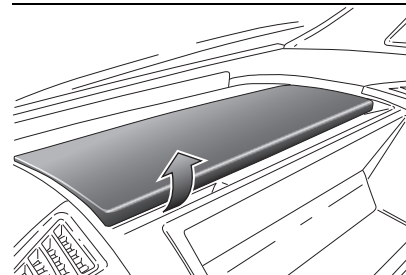

117

F1A0088

### LIGHT UNDER THE DASHBOARD

The lower part of the dashboard has lights that illuminate in the following modes.

**Ignition device in STOP position and engine off:** lights always off.

**Ignition device in MAR position and dipped beam lights off:** lights on permanently with no possibility to adjust their intensity.

**Ignition device in MAR and dipped beam headlights on:** lights on with adjustable intensity.

### GLOVE COMPARTMENT

To open the glove compartment, use the opening handle (A) fig. 118.

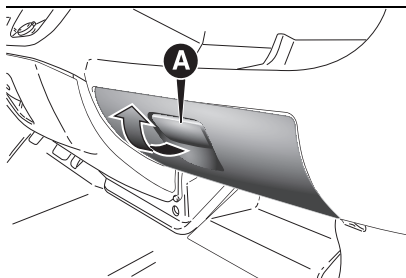

118

F1A0089

## GLOVE COMPARTMENT WITH LOCK

(for versions/markets, where provided)

To lock/unlock the lock, turn the key clockwise/anticlockwise fig. 119.

To open the glove compartment, use the opening handle.

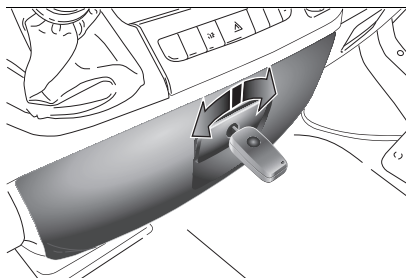

119

F1A0090

## STORAGE COMPARTMENT

(for versions/markets, where provided)

Compartment (A) fig. 120 is located in

the middle of the dashboard. Compartment (B) fig. 121 is located on the right side of the dashboard, above the oddment box.

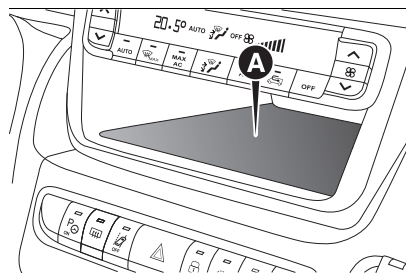

120

F1A0626

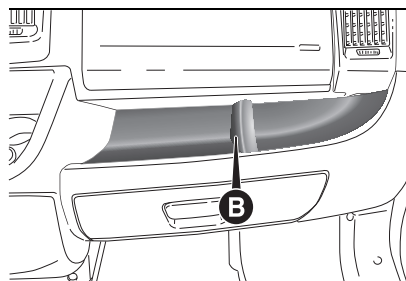

121

F1A0092

## CUP HOLDER - CAN HOLDER - BOTTLE HOLDER ON DASHBOARD

(for versions/markets, where provided)

On a few versions, two cup holders / can holders / bottle holders (0.5 /

0.75 litres) fig. 122 are available on the central dashboard in the place of the storage compartment.

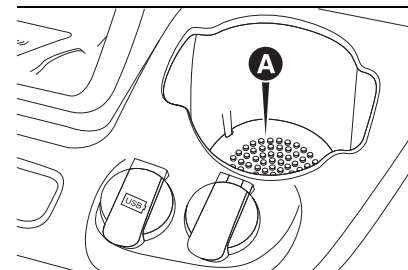

122

F1A0628

## DOOR POCKETS

There are oddment/document pockets fig. 123 located in each of the door panels.

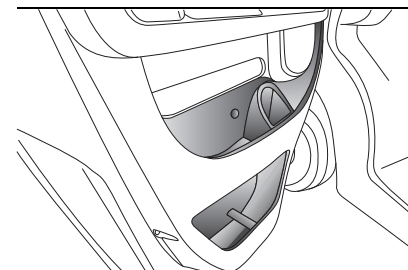

123

F1A0775



## COMPARTMENT BENEATH PASSENGER SIDE FRONT SEAT

Proceed as follows to use the compartment:

- Open the inspection flap (A) fig. 124 and remove it as shown;
- turn the locking knob (B) anticlockwise and remove it to allow the compartment to be removed.

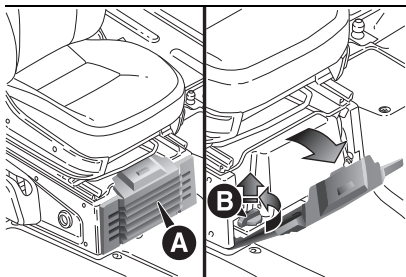

124

F1A0095

## REAR BULKHEAD

The vehicle may be equipped with a solid rear bulkhead or with a sliding glass partition.

To open/close the sliding glass partition, use the knob (A) fig. 125.

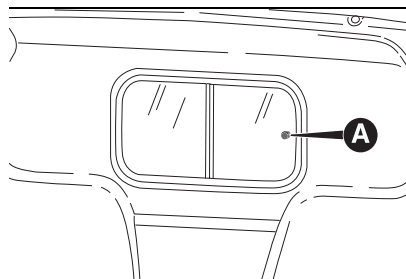

125

F1A0096

Certain outfits are equipped with a protective grille on the window of the partition inside the load compartment.

## WIRELESS CHARGING SYSTEM- WCPM (Wireless Charge Pad Module)

(where provided)

The wireless charging system is activated automatically when a mobile phone is placed in the holder in the glovebox (A) in fig. 126 or in the compartment between the two cup holders at (A) in fig. 127, if the mobile phone is compatible with the Qi® standard.

NOTE The wireless charger device is equipped with an NFC antenna and therefore the "Apple Pay Wallet" function could be activated on iPhone phones: this will not involve any

economic transaction or interruption of charge.

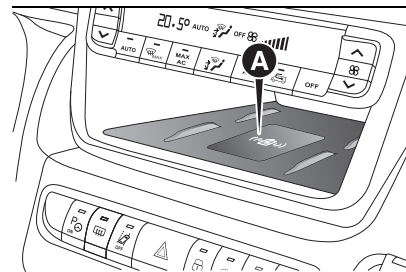

126

F1A0827

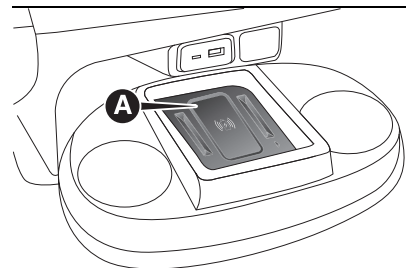

127

F1A0885

If the mobile phone is removed from the housing during the wireless charging phase, this will automatically be interrupted.

The wireless charging system is enabled when the vehicle is in running condition and the vehicle battery is sufficiently charged.

By interacting with the wireless charger system and placing the mobile phone

in the specific housing, the user will be informed by means of a LED indicating the state of the wireless charging system:

- "Your phone is being charged" blue LED: this is displayed when the mobile phone is positioned correctly in the wireless charging compartment and the system is activated correctly;
- "Phone fully charged" green LED: this is displayed when the mobile phone has completed charging its battery (if suitable to transmit the information);
- "Object not allowed" red LED: this is displayed when a phone that is not enabled for wireless charging or an object that is not permitted (e.g. the ignition key) is placed (e.g. ignition key, credit card, a coin);
- "System error" red LED: this appears when there is a malfunction in the wireless charger system;
- "System not active" LED off: there are no objects in the compartment and/or the ignition device of the vehicle in the STOP position and/or the doors are not all closed correctly and the engine is not on.

**WARNING** Do not place contactless cards (RFID), credit cards, metal objects or the vehicle keys in the charging compartment.

**WARNING** Not all mobile phone covers guarantee the correct charging of the phone. Check that charging is in progress after having placed the phone in the charging compartment.

**WARNING** With a compatible smartphone positioned on the charging deck, when you move the ignition device to the STOP position, a warning message will appear on the instrument panel to prevent you from forgetting your smartphone.

**NOTE** The use of multiple wireless functions on the smartphone at the same time (Apple CarPlay/Android Auto and wireless charging), as indicated by the smartphone manufacturers, could cause it to overheat, resulting in a limitation of the active functions or its turning off. In this case, it is recommended to connect the system using the USB socket.

### Correct positioning of the mobile phone

To start wireless charging correctly, make sure the mobile phone is positioned completely inside the glove compartment in fig. 128 or in the housing between the two cup holders in fig. 129 with the display facing up, and

that the device does not cover the alert LED (A).

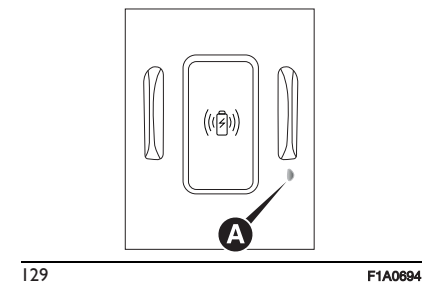
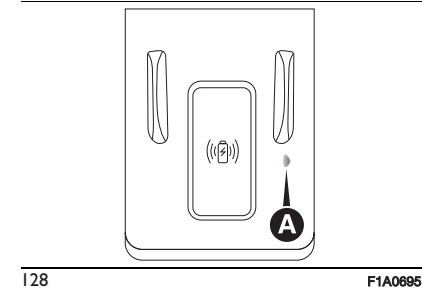

### USB PORTS

(for versions/markets, where provided)

They can be located:

- on the central dashboard (A) fig. 130, for use as a charging source for external equipment;
- on the central tunnel, (B) fig. 131, for connecting USB remote devices





(see explanation in the specific supplements).

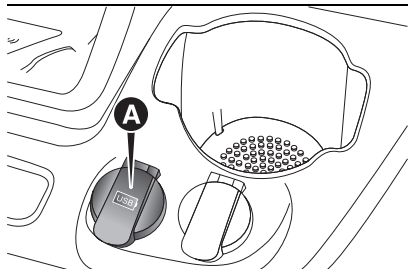

130

F1A0630

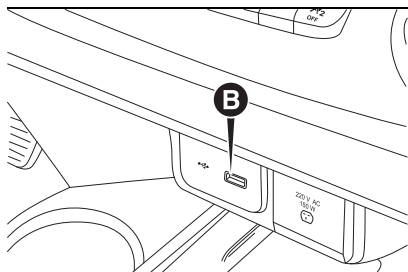

131

F1A0631

### 12V CURRENT SOCKET

(for versions/markets, where provided)  
There may be a power socket located in front of the rear seats ((A) fig. 132).

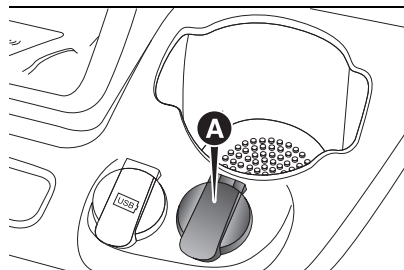

132

F1A0629

**WARNING** The operation of the rear load compartment power socket, where provided, can be switched from "power on ignition only" to "constant battery power". For more information, contact a Fiat Dealership.



### 220V CURRENT SOCKET

(for versions/markets, where provided)

The power socket is located in the centre dashboard. To use it, open the cover (A) fig. 133.

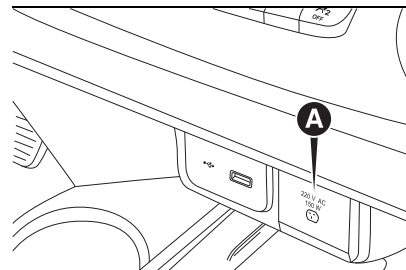

133

F1A0632

### ASHTRAY

The ashtray is a removable plastic container fig. 134 that can be fitted in the cup/can holders in the centre of the dashboard.

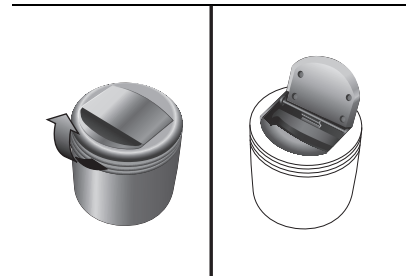

134

F1A0099

**WARNING** Do not use the ashtray also as a waste paper basket: fire hazard.

### SUN VISORS

They are located at the sides of the interior rear-view mirror fig. 135.



They can be adjusted forwards and sideways.

A vanity mirror is fitted on the passenger side sun visor on all versions.

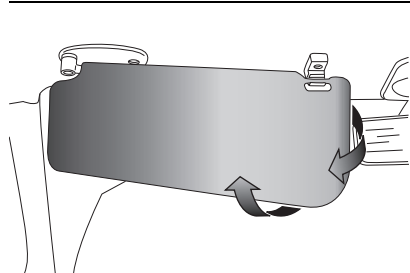

135

F1A0100

**WARNING** On both sides of the passenger side sun visor there is a label advising that it is compulsory to deactivate the airbag if a rear facing child restraint system is fitted. Always comply with the instructions on the sun visor (see the "Front airbag" chapter in the "Safety" section).

### DESK / LECTERN

(for versions/markets, where provided)  
There is a desk (A) fig. 136 in the centre of the dashboard above the radio compartment; on some versions this desk can be used as a book rest by raising the back section and resting it

on the dashboard as illustrated in the figure.

On versions with double passenger side airbag, the desk is fixed.

 49)

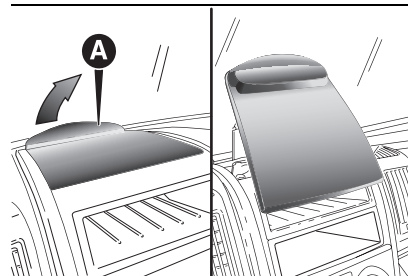

136

F1A0102

### TABLET HOLDER

(for versions/markets, where provided)

It is located in the centre of the dashboard and is designed to anchor a tablet.

Proceed as follows to use fig. 137:

- lower the lever (A) to open the locking devices (B);
- fit the tablet between the locking devices (B);
- lift the lever (A) to ensure that the device is locked.

 50)



137

F1A0342

### SHELF ABOVE THE CAB

(for versions/markets, where provided)

This is located above the driver's cab fig. 138 and is designed to store light objects.

Maximum permitted load:

- localised : 10 kg
- distributed over the entire surface of the shelf: 20 kg

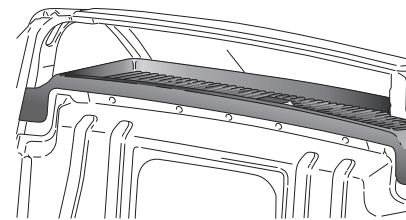

138

F1A0103



### CAB GLOVE COMPARTMENT (CAPUCINE)

(for versions/markets, where provided)  
 The glove compartment is fitted above the sun visors fig. 139 and is designed for the quick storage of light objects (e.g. documents, road maps etc.).

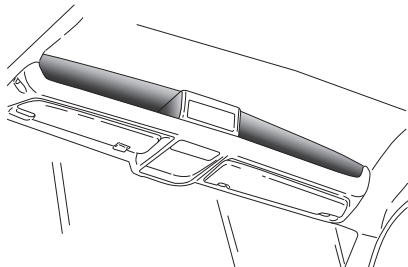

139

F1A0104

### OPEN STORAGE COMPARTMENT

(for versions/markets where provided)  
 On some versions, there is a glove compartment in the middle of the dashboard fig. 140.

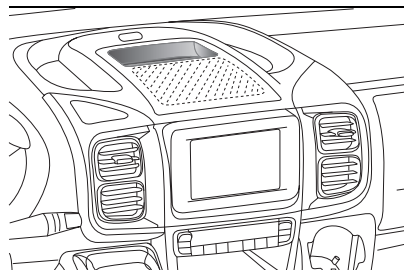

140

F1A0715



51)

### FLAP ON BENCH

(for versions/markets, where provided)  
 To use, pull the tab (A) fig. 141 and lower the flap. The flap is equipped with two cup holder indents and a support surface with a paper holder clip.

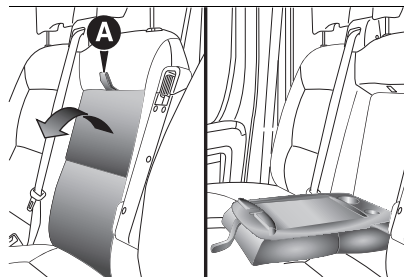

141

F1A0105



### IMPORTANT

- 48)** To prevent serious injury or death: Only devices designed for use in this type of socket should be inserted into any 12 Volt socket. Do not touch the power socket with wet hands. Close the lid when not in use and while driving the vehicle. If this socket is mishandled it may cause an electric shock and failure.
- 49)** Do not use the desk in vertical position with the vehicle in motion.
- 50)** To prevent dangerous situations, moving the tablet holder and using the device are prohibited while driving.
- 51)** Never place potentially dangerous items in the open compartment on the dashboard; in the event of a collision, they may be flung into the passenger compartment and injure the occupants.



### WARNING

- 12)** Accessories connected to the vehicle's power sockets draw current from the battery even when not in use (e.g. mobile phones, etc.). These devices, if left connected too much time with engine off, may cause the battery to drain with following reduction of its life and/or failure to start the engine.
- 13)** Accessories that draw higher power (i.e., coolers, vacuum cleaners, lights, etc.), will degrade the battery even more quickly. Only use these intermittently and with great caution.
- 14)** After the use of high power draw accessories, or long periods of the vehicle

*not being started (with accessories still plugged in), the vehicle must be driven a sufficient length of time to allow the alternator to recharge the battery.*

**15)** *Power sockets are designed for accessory plugs only. Do not insert any other object in the power sockets as this will damage the socket or blow the fuse. Improper use of the power socket can cause damage not covered by your limited warranty of the vehicle.*

## TACHOGRAPH

(for versions/markets, where provided)  
For tachograph operation and use, consult the owner handbook supplied by the device manufacturer. The tachograph must be installed on the vehicle when the vehicle weight (with or without trailer) exceeds 3.5 tons.

**WARNING** Anyone making changes to the monitoring device or signal transmission system that affects recording by the monitoring instrument, particularly if this is done for purposes of fraud, may be in breach of criminal or administrative state regulations.

**WARNING** If a tachograph is fitted, if the vehicle is parked for more than 5 days, it is advisable to disconnect the negative battery terminal to maintain its charge.

## WARNINGS

Do not use abrasive detergents or solvents to clean the device.

To clean the device externally, use a damp cloth or special products for the care of synthetic materials.

The tachograph is installed and sealed by authorised personnel: do not try and access the device or the supply and recording leads in any way. It is the responsibility of the owner of the vehicle on which the tachograph is installed to check the device regularly. The check must be carried out at least every two years and a test must be carried out to ensure it is operating properly. Ensure that the data label is renewed after every check that the label contains the specified data.

## SELF-LEVELLING AIR SUSPENSION

### GENERAL INFORMATION

The system only acts on the rear wheels.

The system maintains the rear ride setting for the vehicle constant in any loading condition, while ensuring a greater driving comfort.

In addition, the system allows the height of the vehicle to be adjusted with the vehicle stationary, by selecting from 7 different positions to facilitate access to the rear compartment.

### HEIGHT ADJUSTMENT

There are 7 pre-defined levels for the free height from the ground: from "ride -3" to "ride 0" till "ride +3".

The ride information is displayed on the instrument panel.

### Automatic adjustment

Whilst driving the system automatically restores the vehicle to "position 0" and keeps it constant.

While adjusting, the LED located on the button ((A) or (B) fig. 142) corresponding to the direction of travel, flashes.



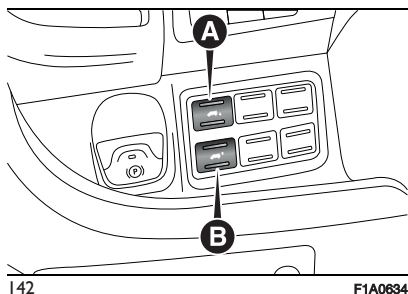

### Manual adjustment



With the vehicle stationary and the engine on or off, the desired height level can be set.

Manual adjustment is only available for a limited number of times with the engine switched off.

Pressing button (A), for less than 1 second, selects the next level up.

Keeping button (A) pressed for more than 1 second directly selects the maximum level: "position +3".

Pressing button (B), for less than 1 second, selects the next level down.

Keeping button (B) pressed for more than 1 second directly selects the minimum level: "position -3".

While adjusting, the LED located on the button ((A) or (B) ) corresponding to the direction of travel, flashes.

### Adjustment not available

If, after selecting a button, the LED remains lit up (for about 5 seconds) rather than flashing, this means that the adjustment is temporarily unavailable.

Possible causes may be as follows:

- ❑ insufficient air reserve: the function is restored by starting the engine;
- ❑ the system has reached a threshold working temperature: wait a few minutes to let it cool down before operating the buttons again.

The level selected with the vehicle stationary is maintained up to a speed of about 20 km/h; when this speed is exceeded, the system will automatically restore the normal level: "position 0".



### WARNING

**16)** Before manually adjusting with doors open, make sure there is enough space around the vehicle for this kind of operation.

## ROOF RACK/SKI RACK

To fit the roof/ski rack, with provision for versions H1 and H2, use the pins (A) on the edges of the roof fig. 143.

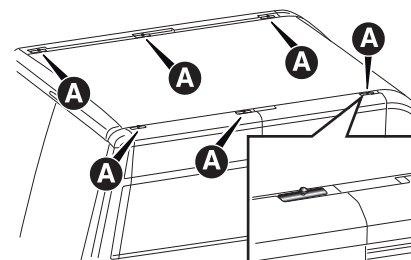

Long wheelbase vehicles are equipped with 8 pins; short or medium wheelbase vehicles are equipped with 6 pins; vehicles with extra-long wheelbases are equipped with 10 pins.



52) 53)



17) 18)

**WARNING** Follow the instructions contained in the assembly kit carefully. Assembly must be performed by qualified personnel.



## IMPORTANT

**52)** After travelling for a few kilometres, check to ensure that the fixing screws for the attachments are well tightened.

**53)** Distribute the load evenly and pay attention to side winds when driving.



## WARNING

**17)** Fully comply with the regulations in force concerning maximum clearance.

**18)** Never exceed the maximum permitted loads (see "Technical Specifications" section).

## ACCESSORIES PURCHASED BY THE OWNER

If after buying the vehicle, you decide to install electrical accessories that require a permanent electric supply (alarm, satellite anti-theft system, etc.) or accessories that in any case burden the electric supply, contact a Fiat Dealership, whose qualified personnel, besides suggesting the most suitable devices from Lineaccessori MOPAR, will also evaluate the overall electric consumption, checking whether the electrical system of the vehicle can withstand the load required, or whether

it needs to be integrated with a more powerful battery.



## INSTALLING ELECTRICAL/ELECTRONIC DEVICES

Electrical and electronic devices installed after buying the vehicle and available as after-sales must carry the following label fig. 144.



144

E-CE

The Manufacturer authorises the fitting of transceivers provided that installation is carried out at a specialised centre, in a workmanlike fashion and in compliance with manufacturer's specifications.

**WARNING** Traffic authorities may not allow the vehicle on the road if devices are fitted that involve modifications to the features of the vehicle. This may also cause lapse of the warranty in relation to faults caused by the change or either directly or indirectly related to it.

The Manufacturer shall not be liable for damage caused by the fitting of accessories either not supplied or recommended by the Manufacturer and/or not installed in compliance with the provided instructions.

## RADIO TRANSMITTERS AND MOBILE PHONES

Radio transmitters (car phones, CB radios etc.) cannot be used inside the vehicle unless a separate aerial is mounted externally.

**WARNING** The use of such devices inside the passenger compartment (without an external aerial) may, in addition to potential damage to the health of the passengers, cause malfunctions in the vehicle electronic systems, compromising the safety of the vehicle. In addition, the transmission and reception of these devices may be affected by the shielding effect of the vehicle body. As far as the use of EC-approved mobile phones is concerned (GSM, GPRS, UMTS), follow the usage instructions provided by the mobile phone manufacturer.



## SETUP FOR FITTING TELEPASS ON REFLECTIVE WINDSCREEN

(for versions/markets, where provided)

If the vehicle is equipped with a reflective windscreen, install the Telepass in the appropriate area shown in fig. 145 - fig. 146.

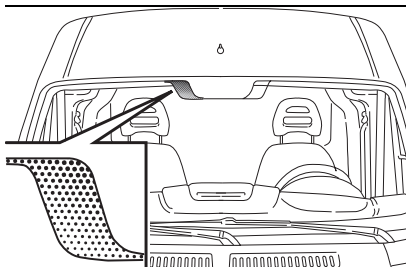

145

F1A0310

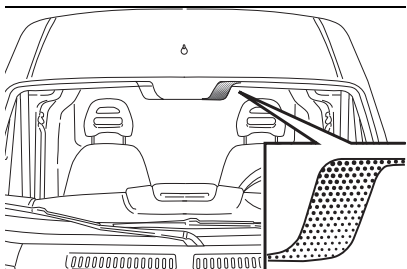

146

F1A0311



### IMPORTANT

**54)** *Take care when fitting additional spoilers, alloy wheels or non-standard wheel hubs: they could reduce the ventilation of the brakes and affect efficiency under sharp, repeated braking or on long descents. Make sure that nothing obstructs the pedal stroke (mats, etc.).*

## PROTECTING THE ENVIRONMENT

The following devices are used for reducing diesel fuel engine emissions:

- oxidising catalytic converter;
- exhaust gas recirculation system (EGR);
- particulate filter (DPF) (for versions/markets, where provided).



55)

### DIESEL PARTICULATE FILTER (DPF)

The Diesel Particulate Filter is a mechanical filter, integral to the exhaust system, that physically traps carbon particles present in the exhaust gases of diesel engines.

The diesel particulate filter has been adopted to eliminate almost all particulates in compliance with current / future legal regulations.

During normal use of the vehicle, the Powertrain Control Module records a

set of data (travel time, type of route, temperatures reached etc.) and calculates how much particulate has been trapped by the filter.

Since this filter physically traps particulate, it should be regenerated (cleaned) at regular intervals by burning carbon particles.

The regeneration procedure is controlled automatically by the Powertrain Control Module according to the filter conditions and vehicle usage conditions.

During regeneration, the following may occur: a limited increase in the engine speed, activation of the fan, a limited increase in fumes and high temperatures at the exhaust.

These are not faults; they do not impair vehicle performance or damage the environment. If the dedicated message is displayed, refer to the "Warning lights and messages" section.



### IMPORTANT

**55)** *The Diesel particulate filter (DPF) reaches high temperatures during normal operation. Do not park the vehicle on flammable material (grass, dry leaves, pine needles etc.): fire hazard.*

# KNOWING THE INSTRUMENT PANEL

*This section of the handbook provides all information that is useful for getting to know, interpreting, and using the instrument panel correctly.*

|                                      |    |
|--------------------------------------|----|
| EOBD SYSTEM .....                    | 82 |
| INSTRUMENT PANEL<br>FEATURES.....    | 83 |
| DISPLAY .....                        | 87 |
| WARNING LIGHTS AND<br>MESSAGES ..... | 94 |



## **EOBD SYSTEM**

The EOBD system (European On Board Diagnosis) allows continuous diagnosis of emission-related components on the vehicle to be made.

It also alerts the driver, by switching on the  warning light on the instrument panel, when these components are no longer in peak condition (see “Warning lights and messages” chapter).

The aim of the system is to:

- monitor system efficiency;
- indicate an increase in emissions due to vehicle malfunction;
- indicate the need to replace components which have deteriorated.

The system also has a connector that can be interfaced with appropriate equipment, which makes it possible to read the error codes stored in the control unit together with a series of specific parameters for engine operation and diagnosis. This check can also be carried out by traffic control authorities.

**WARNING** After eliminating the failure, to check the system completely, Fiat Dealerships run a bench test and, if necessary, road tests which may also call for a long journey.



# INSTRUMENT PANEL FEATURES

## 3.5" DISPLAY HEAVY DUTY VERSION

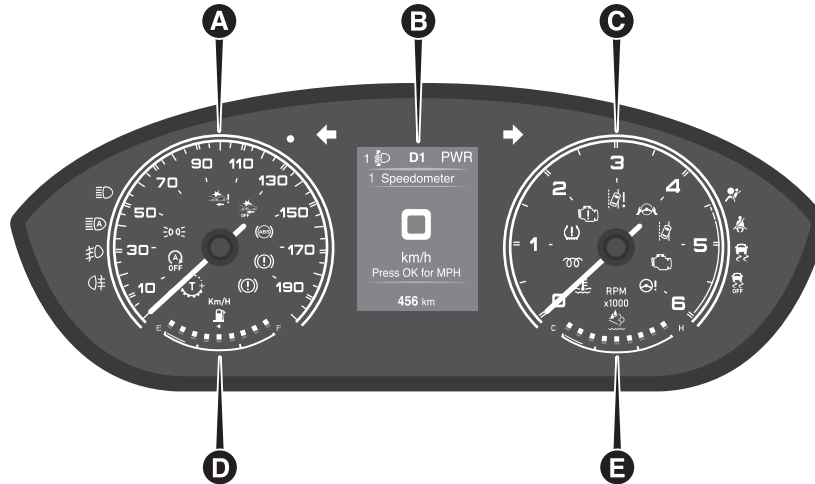

147

F1A0890

A. Speedometer B. Multifunction display C. Tachometer D. Fuel level gauge E. AdBlue<sup>®</sup> diesel emissions additive level gauge

WARNING The illumination of the instrument panel graphics may vary according to version.



3.5" DISPLAY LIGHT DUTY VERSION

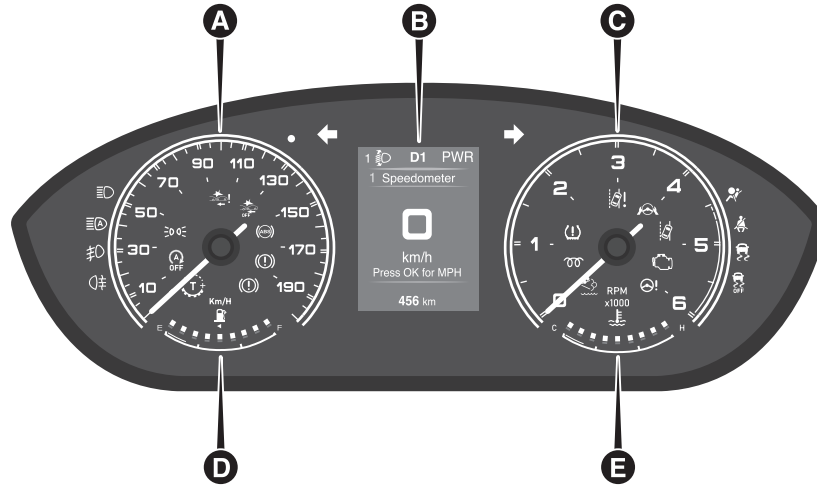

148

F1A0891

A. Speedometer B. Multifunction display C. Tachometer D. Fuel level gauge E. Engine coolant temperature gauge

WARNING The illumination of the instrument panel graphics may vary according to version.

## 7" DISPLAY

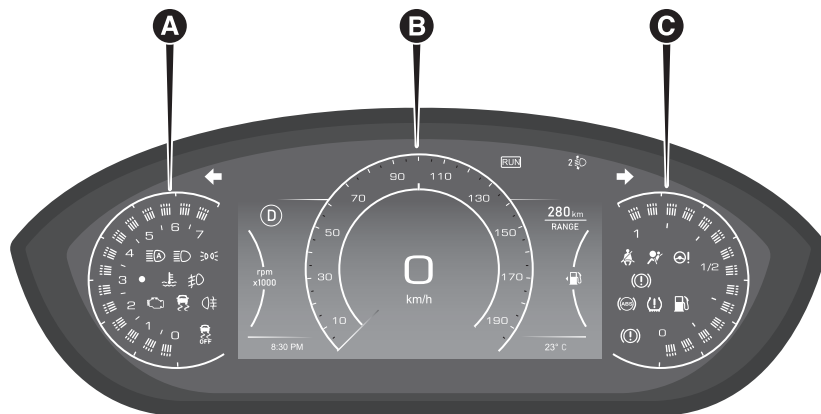

149

A. Tachometer B. Speedometer and multifunction display C. Fuel level gauge

WARNING The illumination of the instrument panel graphics may vary according to version.

F1A0686



**SPEEDOMETER (speed indicator)**

Indicator (A) shows the speed of the vehicle.

**TACHOMETER**

Indicator (C) shows the engine revs.

**WARNING** The electronic injection control system gradually shuts off the flow of fuel when the engine is over-revving, resulting in a gradual loss of engine power.

When the engine is idling, the rev counter may indicate a gradual or sudden increase of the speed.

This is normal and does not indicate a fault. It may be caused, for example, by the activation of the climate control system or fan. In these cases, a slow change in revs is used to protect the battery charge.

**FUEL LEVEL GAUGE**

The digital indicator (D) shows the amount of fuel left in the fuel tank.

(E) - Tank empty.

(F) - Tank full (see the description in paragraph "Vehicle refuelling" chapter in the "Starting and driving").

The warning light on the indicator switches on when there are about 10-12 litres of fuel (for versions with

tank capacity 75-90 litres) or 9 litres (for versions with tank capacity 60 litres) remaining in the tank.

Do not travel with the tank nearly empty to prevent damaging the catalytic converter.

**WARNING** The hand will point to (E) and the warning light will flash to indicate a fault in the system. If this is the case, go to a Fiat Dealership to have the system checked.

**WARNING** It is not advisable to activate the additional Webasto heater in reserve conditions.

**ENGINE COOLANT TEMPERATURE INDICATOR**

The digital gauge (E) fig. 148 indicates the temperature of the of engine coolant and starts giving indications when the coolant temperature exceeds approximately 50°C. In normal use of the vehicle, the indicator will show the various positions on the scale according to the conditions of use of the vehicle.

(C) - Low engine coolant temperature.

(H) - High engine coolant temperature.

The warning light on the indicator indicates that the temperature of

the engine coolant has increased excessively. In this case, stop the engine and contact a Fiat Dealership.

**AdBlue® DIESEL EMISSIONS ADDITIVE LEVEL GAUGE**

The digital gauge (E) fig. 147 indicates the level of AdBlue® diesel emissions additive. In normal use of the vehicle, the indicator will show the various positions on the scale according to the conditions of use of the vehicle.

(E) - Tank empty.

(F) - Tank full (see the description in paragraph "Vehicle refuelling" chapter in the "Starting and driving").

**WARNING**

**19)** *If the indicator for the engine coolant temperature reaches the red area, stop the engine immediately and contact a Fiat Dealership.*

## DISPLAY

### DESCRIPTION

The vehicle is equipped with a display (B) fig. 147 and fig. 148 that can show useful information to the driver while driving.

With the ignition device in the STOP position and the key removed, the display lights up and shows the time and total odometer reading (in km or miles) for a few seconds when a door is opened/closed.

### GEAR SHIFT INDICATOR

The Gear Shift Indicator (GSI) system gives an indication in a specific indication in area (A) fig. 150 for versions with 3.5" display or (A) fig. 151 on 7" display of the instrument panel to advise the driver when to shift gear.

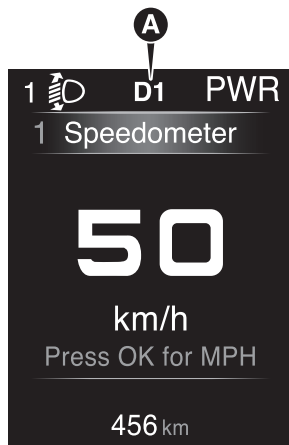

150

F1A0892



151

F1A0655

Through the GSI, the driver is informed that the gear change will allow a reduction in fuel consumption.

When the ▲ / ► symbol appears on the display, the GSI is advising the driver to shift up, while the ▼ / ◀ symbol advises the driver to shift down. The indication in the display remains until a gear is shifted or the driving conditions go back to a situation where gearshifting is not required to improve consumption.

On some versions, the engaged gear and the recommended one are displayed next to the ▲ / ► or ▼ / ◀ symbol.

Icons ▲ / ► or ▼ / ◀ may appear when the GSI recommends shifting to a gear two steps higher than the currently engaged one. On these versions, the system only displays the engaged gear when the driving conditions do not make it necessary to change gear to optimise fuel consumption.

The indications of the engaged gear and the recommended gear shift temporarily disappear from the display during a gear shift and reappear as soon as the gear shift is finished.

### CONTROL BUTTONS

They are located on the steering wheel fig. 152 and allow the driver to select and interact with the items in the Main



menu of the display (see the "Display screens" paragraph).

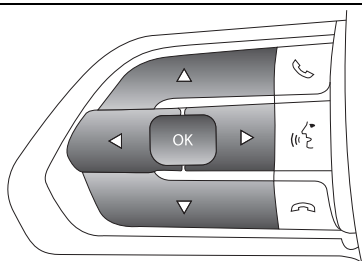

152

F1A0637

□  $\Delta$  /  $\nabla$ : press and release the buttons to access the Main menu and to scroll the menu and the submenus upwards or downwards.

□  $\triangleleft$  /  $\triangleright$ : press and release the buttons to access the information screens or the submenus of an item of the Main menu.

□ **OK**: press this button to access/select the info displays or the submenus of an item of the Main menu. Hold the button pressed for 1 second to reset the displayed/selected functions.

### 3.5" DISPLAY

The display fig. 153 will show the following information:

- A** Headlight alignment position
- B** Gear Shift Indicator, Start&Stop

**C** Drive Mode, rear Seat Belt Reminder (where provided)

**D** Navigation indications, menu title identification number

**E** Reconfigurable zone. Title menu, Seat Belt Reminder (where provided)

**F** Main area

**G** Odometer, Cruise Control, Traffic Sign Recognition, Hill Descent Control

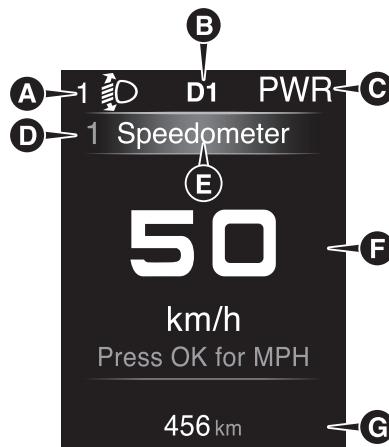

153

F1A0889

### 7" DISPLAY

The following information appears on the display fig. 154 (Heavy Duty

version) and fig. 155 (Light Duty version).

**A** Driving assistance device indications

**B** Multi-function dial indicator: speedometer and driver assistance system indication

**C** Seat belt status indication

**D** Yellow symbols

**E** GSI indications - reconfigurable area

**F** Speedometer and driving assistance device indications

**G** Red symbols

### Heavy Duty Version

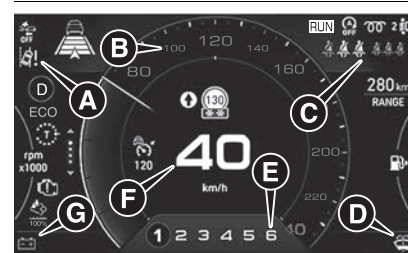

154

F1A0854

## Light Duty Version



155

F1A0657

## DISPLAY SCREENS

You can navigate through the following main and detail screens using the controls on the steering wheel.

The menus are indicative and may vary for versions and markets.

### Screenshot list

#### 7" DISPLAY

##### Main screen

By pressing and releasing  $\Delta/\nabla$  the user can choose to display:

the multifunction dial indicator showing the speed of the vehicle

or:

- $\triangleleft/\triangleright$   the multifunction dial indicator showing the speed of the vehicle, plus the indicator recommending the gear to engage

Home

- Speedometer  
 Speedometer + GSI

Trip

Press and release  $\Delta/\nabla$ :

- Trip A  
 Trip B

Driver assist

- Adaptive Cruise Control  
 Lane Departure Warning  
 Traffic Sign Recognition  
 Intelligent Speed Assist

Vehicle info

Press and release  $\Delta/\nabla$ :



- Tyre pressure  
 Coolant temp  
 Oil level  
 Oil temperature  
 Oil life  
 Battery charge  
 Suspension level  
 AdBlue (\*)  
 Service (scheduled servicing)

Audio

Phone

Navigation

Alerts

Settings

- Display  
 Units  
 Date and Time  
 Safety  
 Brakes  
 Safety / Assistance  
 Mirrors and windscreen wipers  
 Lights  
 Doors & Locks  
 Idle preset  
 Engine switch off procedure

#### 3.5" DISPLAY

Trip



- Instant information  
 Trip A  
 Trip B  
 Speedometer

GSI (Gear Shift Indicator) (only for manual transmission versions)

Vehicle info

- Tyre pressure  
 Coolant temp  
 Oil level  
 Oil temperature  
 Oil life  
 Battery charge  
 Suspension level  
 AdBlue (\*)  
 Service (scheduled servicing)



Driver Assist

- Adaptive Cruise Control
- Lane Departure Warning
- Traffic Sign Recognition
- Intelligent Speed Assist

Audio

Telephone relay (where provided)

Navigation relay (where provided)

Messages

Settings



- Display
- Units
- Date and Time
- Safety
- Brakes
- Safety / Assistance
- Mirrors and windscreen wipers
- Lights
- Doors & Locks
- Idle preset

In the case of multiple screens, indicates the presence of screens to the right and/or left of those displayed. Scrolling between pages is possible using the arrows / .

(\*) Light Duty versions only

**Trip computer**

The "Trip computer" screen (fig. 156) can be used to view several

parameters relating to the operational status of the vehicle. This function has two separate memories, "Trip A" and "Trip B", where the data for the "complete journeys" (trips) of the vehicle is recorded independently from each other.

Press the or button to switch from "Trip A" to "Trip B" and vice versa.



156 F1A0787

The screen can be used to show the following items: "Current consumption", "Average consumption", "Distance", "Average speed", "Travel time".

The sizes are displayed in "km"/"mi" and "km/h"/"mph" depending on the display settings.

Both values can be reset: press and hold down the OK button on the steering wheel.

NOTE The total consumption cannot be reset.

**Driver assist**

This screen in area (A) fig. 157 (for the 3.5" display) or (A) fig. 158 (for the 7" display) shows messages and visual indications of the following driving assistance systems:

- CC (Cruise Control)
- ACC (Adaptive Cruise Control);
- TSR (Traffic Sign Recognition) / TSI (Traffic Sign Information);
- ISA (Intelligent Speed Assist).

As more recent notifications are shown, previous notifications are overwritten.

NOTE After a few seconds, the title of the selected function may change to show what was previously set ((E) fig. 153).





157

F1A0886

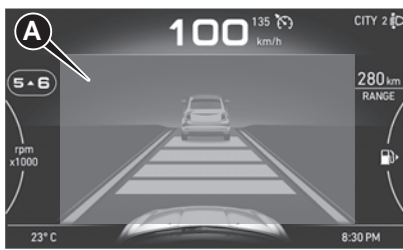

158

F1A0639

For some driving assistance devices, pop-up warnings are marked in yellow

or red at the bottom of the screen according to the type of warning. Refer to the "Starting and Driving" section for more information about driving assistance systems.

### Vehicle info

The screen shows the following information:

- Tyre pressure
- Coolant temp
- Oil level
- Oil temperature
- Oil life
- Battery charge
- Suspension level
- AdBlue (Light Duty versions only)
- Service (scheduled servicing)

Press the  $\Delta$  or  $\nabla$  button to switch between the "Tyre pressure" screen and the "Service" screen.

### Oil level

The indicator fig. 159 or fig. 160 (depending on the version) graphically displays the oil level in the engine.

To see the oil level, turn the key to MAR; the oil level will appear on the display by lighting a six-notch indicator bar. Two additional notches indicate underfilling and overfilling.



159

F1A0880



160

F1A0760

If the oil level is lower than the minimum required value, the display shows a dedicated message indicating minimum engine oil level and the need for a top-up.

After a few seconds, the symbol display indicating the amount of engine oil disappears and:

- if the next scheduled servicing intervention is approaching, the time to the next service is displayed and the symbol  lights up on the display.



When the service interval has expired a dedicated alert will be shown on the display;

later on, if the time for changing the engine oil is getting close, the distance until the next oil change will appear on the display. When the service interval has expired a dedicated alert will be shown on the display.

### Audio

(where provided)

This screen repeats the audio playback information shown on the **Uconnect™** system (where provided):

- FM/DAB radio;
- Media (USB, **Bluetooth®**);
- Android Auto, Apple CarPlay, Baidu Carlife.

Refer to the "Multimedia" section for more information.

### Phone

(where provided)

This screen repeats the information displayed on the **Uconnect™** system while interacting with a paired phone. The following information is shown:

- Call status;
- Connected phone status (battery state of charge, network reception, incoming/outgoing call notification, received text messages notification);

### Recent call list.

The system stores the last 10 received messages marked "read" or "unread". The user can select the desired message using the steering wheel controls  $\Delta$ / $\nabla$  and open it by pressing the OK button on the steering wheel.

Refer to the "Multimedia" section for more information.

### Navigation

(where provided)

This screen repeats the instructions provided by the **Uconnect™** system navigator. The display can be pictogram or map (the latter for the 7" version).

Refer to the "Multimedia" section for more information.

### Alerts

This display displays the recorded messages and pop-ups previously displayed by the user.

### Settings (Change vehicle settings)

This screen allows you to customise the displays and notifications on the display and the various functions of the vehicle.

NOTE The tachograph components are illustrated below. The menus may vary depending on the equipment of the vehicle.

NOTE Some settings may be managed using the **Uconnect™** system (see "Settings" in the "Vehicle mode" paragraph in the "Multimedia" section).

NOTE The lists of menu items are indicative.

In particular, this function allows you to change the settings for:

### Display

Selecting this item accesses the following settings (where provided):

- Language: this sets the display language.
- Screen brightness: on 8 levels.
- Automatic Trip B reset.
- Phone Repeat: enable/disable.
- Navigation repeat: enable/disable (map and pictograms also available for 7" version).

### Units

Selecting the item you can choose the unit of measurement to be used for displaying the various values:

- US/ metric (where provided).
- Metric/ Imperial (where provided).
- Customisable parameters: speed, distance, consumption, pressure, temperature (where provided).

### Date and Time

Select this item to make the following adjustments (where provided):

- Time setting.
- Format setting: 12 hours/24 hours.
- Date setting.

#### Safety

Select this item to make the following adjustments (where provided):

- Passenger airbag: enable/disable.
- Seat Belt Reminder: enable/disable.
- Speed alarm: enable/disable.
- Hill Start Assist warning: enable/disable.

#### Brakes

Select this item to make the following adjustments (where provided):

- Brake service.
- Auto Park Brake: enable/disable electric parking brake automatic engagement.

#### Safety / Assistance

Select this item to make the following adjustments (where provided):

- Buzzer volume: off, low level, medium level, high level.
- Lane Sense warning: early, medium, delayed.
- Lane Sense strength: low, medium, high.
- Intelligent Speed Assist: confirmation, automatic.

- Traffic Sign Assist: enable, disable.
- Traffic Sign Assist alert: off, visual, visual and acoustic.
- New speed detection: off, visual, audible.
- Forward Collision Warning: on/off.
- Forward Collision Warning sensitivity: near, medium, far.
- Warning Side Distance: enable, disable.
- Park Sense: acoustic, acoustic and visual.
- Rear Park Sense volume: near, medium, far.
- Front Park Sense volume: near, medium, far.
- Attention Assist warning: enable, disable.
- Blind Spot warning: visual/visual and acoustic/off.
- Trailer length for Blind Spot Alert: automatic, max.

#### Mirrors and windscreen wipers

Select this item to make the following adjustments (where provided):

- Rain sensor: enable, disable.

#### Lights

Select this item to make the following adjustments (where provided):

- Dipped beam sensitivity: 1 to 3.

- Courtesy lights: 0, 30, 60, 90 seconds.
- Automatic main beam: enable, disable.
- Cornering lights: enable, disable.

#### Doors & Locks

Select this item to make the following adjustments (where provided):

- Automatic door lock: enable, disable.
- Door unlock on exit: enable, disable.
- Flash dipped beam headlights when closing: enable/disable.
- Horn on door lock: enable, disable.
- Passive Entry: enable, disable.

#### Idle Preset

This allows the following adjustments to be made to the "Engine Idle Preset" function (where provided):

- Idle Preset activation: enable, disable.
- Idle speed selection: from 900 rpm to 2200 rpm.

#### Engine stopping procedure

Select this item to switch off the engine in the event of a fault in the Keyless Enter-N-Go system, following the procedure described on the display (where provided).















## WARNING LIGHTS AND MESSAGES

The warning light can switch on together with (where the instrument panel permits) a specific message and/or acoustic warning. These indications are indicative and precautionary and as such must not be considered as exhaustive and/or alternative to the information contained in the Owner Handbook, which you are advised to read carefully in all cases. Always refer to the information in this section in the event of a failure indication.



**WARNING** The failure indicators appearing on the display are divided into two categories: very serious and less serious failures. Serious faults are indicated by a repeated and prolonged warning "cycle". Less serious faults are indicated by a warning "cycle" with a shorter duration. The display cycle of both categories can be interrupted. The instrument panel warning light will stay on until the cause of the malfunction is eliminated.

### Warning lights on panel

|  | What it means   |
|--|---|
| <br>red | <p><b>INSUFFICIENT BRAKE FLUID / PARKING BRAKE ON</b><br/>The warning light switches on when the key is turned to MAR-ON, but it should switch off after a few seconds.</p> <hr/> <p><b>Low brake fluid level</b><br/>The warning light turns on when the level of the brake fluid in the reservoir falls below the minimum level, possibly due to a leak in the circuit.<br/>Restore the brake fluid level, then check that the warning light has switched off.<br/>If the warning light switches on while driving, stop immediately and contact a Fiat Dealership.</p> <hr/> <p><b>Parking brake on</b><br/>The warning light switches on when the parking brake is engaged.<br/>Release the parking brake, then check that the warning light has switched off.<br/>If the warning light stays on, contact a Fiat Dealership.</p> |
| <br>red | <p><b>EBD FAILURE</b><br/>The simultaneous switching on of the  (red),  (amber) and  (amber) warning lights (for versions/markets, where provided), with the engine on, indicates either a fault of the EBD system or that the system is not available. In this case, the rear wheels may suddenly lock and the vehicle may swerve when braking sharply. Drive very carefully to the nearest Fiat Dealership to have the system inspected immediately.</p>   |

|   | What it means   |
|---|---|
| <br>yellow amber | <b>EBD FAILURE</b><br>The simultaneous switching on of the  (red),  (amber) and  (amber) warning lights (for versions/markets, where provided), with the engine on, indicates either a fault of the EBD system or that the system is not available. In this case, the rear wheels may suddenly lock and the vehicle may swerve when braking sharply. Drive very carefully to the nearest Fiat Dealership to have the system inspected immediately. |
| <br>yellow amber |   |
| <br>red          | <b>AIRBAG FAILURE</b><br>The warning light switches on when the ignition key is turned to MAR, but it should switch off after a few seconds.<br>The warning light stays on constantly if there is a fault in the airbag system.<br> <b>56) 57)</b>   |
| <br>red          | <b>SEAT BELTS REMINDER</b><br>(for versions/markets, where provided)<br>The warning light switches on constantly with the vehicle stationary and the driver's seat belt not fastened. The warning light flashes and an acoustic warning will sound if the vehicle is in motion and the driver's seat belt is not correctly fastened.<br>For permanent deactivation of the acoustic signal (buzzer) of the SBR (Seat Belt Reminder) system contact a Fiat Dealership. With the multifunction display, you can also reactivate the system through the Setup menu.   |



|  | What it means   |
|--|---|
|  <p data-bbox="293 356 325 371">red</p> | <p data-bbox="453 114 900 132"><b>ENGINE COOLANT TEMPERATURE TOO HIGH</b></p> <p data-bbox="453 138 1426 183">The warning light switches on when the ignition key is turned to MAR, but it should switch off after a few seconds. The warning light turns on when the engine is overheated.</p> <p data-bbox="453 190 1497 235"><b>NOTE</b> The screen-printed icon indicating excessive engine coolant temperature is only provided on versions with reconfigurable multifunction display.</p> <p data-bbox="453 241 1500 362">In normal driving conditions: stop the vehicle, switch off the engine and check that the water level in the reservoir is not below the MIN mark. In this case, wait for the engine to cool down, then slowly and carefully open the cap, top up with coolant and check that the level is between the MIN and MAX marks on the reservoir itself. Also check visually for any fluid leaks. If, when restarting, the warning light switches on again, contact a Fiat Dealership.</p> <p data-bbox="453 369 1497 465">If the vehicle is used under demanding conditions (e.g. in high-performance driving): slow down and, if the warning light stays on, stop the vehicle. Stop for two or three minutes with the engine running and slightly accelerated to facilitate better coolant circulation, then turn the engine off. Check that the coolant level is correct as described above.</p> <p data-bbox="453 472 1481 517"><b>WARNING</b> Over demanding routes, it is advisable to keep the engine running and slightly accelerated for a few minutes before turning it off.</p>   |
|  <p data-bbox="293 799 325 815">red</p> | <p data-bbox="453 545 833 563"><b>ELECTRIC POWER STEERING FAILURE</b></p> <p data-bbox="453 570 1477 614">The warning light switches on when the ignition device is brought to the MAR position, but it should switch off after a few seconds.</p> <p data-bbox="453 621 1500 691">If the warning light remains on, you could not have power steering and the effort required to operate the steering wheel could increase considerably, however it is still possible to steer the vehicle. In this case, contact a Fiat Dealership.</p> <p data-bbox="453 697 1506 767">If the warning light comes on while driving you may not have steering assistance. Although it will still be possible to steer the vehicle, the effort needed to operate the steering wheel could be increased: contact a Fiat Dealership as soon as possible.</p> <p data-bbox="453 773 1503 870"><b>IMPORTANT</b> In some circumstances, factors independent of the electric power steering could cause the warning light on the instrument panel to switch on. In this case, stop the vehicle immediately (if you are moving), stop the engine for about 20 seconds (taking the ignition device to the STOP position) and then restart the engine. If the warning light stays on, contact a Fiat Dealership.</p> <p data-bbox="453 876 1493 946"><b>IMPORTANT</b> The steering must be initialised after disconnecting the 12V battery. The warning light turns on to indicate this. To carry out this procedure, slowly turn the steering wheel all the way from one end to the other or drive in a straight line for about a hundred metres.</p> <p data-bbox="453 953 695 971">Contact a Fiat Dealership.</p> |

What it means



red

ANTI-INTRUSION WARNING

(for versions/markets, where provided)

The warning light flashes to indicate that the anti-intrusion system has intervened.



red

HANDS NOT DETECTED ON STEERING WHEEL

(for versions/markets, where provided)

The warning light, or the symbol in the display, is shown when the driver's hands are not detected on the steering wheel for an extended period of time.



yellow amber

HANDS NOT DETECTED ON STEERING WHEEL

(for versions/markets, where provided)

The warning light, or the symbol in the display, is shown when the driver's hands are not detected on the steering wheel for a few seconds.



yellow amber

EOBD/INJECTION SYSTEM FAILURE

In normal conditions, when the ignition key is turned to MAR the warning light switches on, but it should switch off as soon as the engine is started.

The operation of the  warning light may be checked by the traffic police using specific devices. Comply with the laws and regulations of the country where you are driving.



yellow amber





If the warning light or symbol on the display stays on or switches on when driving, it means that the injection system is not working properly; in particular, if the warning light or symbol comes on constantly, this indicates a malfunction in the supply/ignition system that could cause excessive exhaust emissions, a possible loss of performance, poor driveability and high fuel consumption.

The warning light or symbol on the display switches off if the malfunction disappears, but is still stored by the system.

Under these conditions, the vehicle can continue travelling at moderate speed without demanding excessive effort from the engine. Prolonged use of the vehicle with the warning light on may cause damage.

Contact a Fiat Dealership as soon as possible.



|   | What it means  |
|---|--|
|  <p>yellow amber</p> | <p><b>AdBlue® (UREA) INJECTION SYSTEM FAILURE</b></p> <p>The warning light comes on, together with a dedicated message on the panel (for versions/markets, where provided) if a liquid not conforming with the nominal characteristics is injected, if an average consumption of AdBlue® (UREA) greater than or less than 50% is detected or in the event of failures that could compromise the correct operation of the AdBlue® injection system.</p> <p>Contact a Fiat Dealership as soon as possible.</p> <p>If the fault is not solved, a dedicated message will appear on the instrument panel display whenever a certain threshold is reached until it will no longer be possible to start the engine.</p> <p>When 200 km are left before you will no longer be able to restart the engine, a continuous dedicated message will appear on the display (for versions/markets, where provided) accompanied by an acoustic warning sound.</p> |
|  <p>yellow amber</p> | <p><b>ABS FAILURE</b></p> <p>The warning light switches on when the ignition key is turned to MAR, but it should switch off after a few seconds.</p> <p>The warning light switches on to indicate a system fault. In this case the braking system maintains its efficiency unaltered but without the advantage of the ABS system.</p> <p>Drive carefully and contact a Fiat Dealership as soon as possible.</p>  |
|  <p>yellow amber</p> | <p><b>FUEL RESERVE</b></p> <p>The warning light switches on when the ignition key is turned to MAR, but it should switch off after a few seconds. The warning light switches on when there are about 10/12 litres of fuel (for versions with tank capacity 75/90 litres) or 9 litres (for versions with tank capacity 60 litres) remaining in the tank.</p> <p>On some versions, the triangle on the right side of the warning light indicates the side of the vehicle with the fuel filler.</p> <p>The warning light will blink to indicate a system fault. If this is the case, go to a Fiat Dealership to have the system checked.</p>  |
|  <p>yellow amber</p> | <p><b>GLOW PLUG PREHEATING / GLOW PLUG PREHEATING FAILURE</b></p> <p><b>Glow plugs</b></p> <p>This warning light or symbol on the display switches on when the key is turned to MAR. It will switch off as soon as the glow plugs have reached a preset temperature.</p> <p><b>WARNING</b> When it is particularly warm outside, the warning light stays on for an extremely short time.</p> <p>Start the engine as soon as the warning light switches off.</p>  |



What it means



yellow amber

**Glow plug preheating failure**

The warning light or symbol on the display flashes if there is a fault in the glow plug preheating system. Contact a Fiat Dealership as soon as possible.



yellow amber

**LOW AdBlue® (UREA) DIESEL EMISSIONS ADDITIVE LEVEL WARNING**  
(for versions/markets, where provided)

The warning light or the symbol in the display will come on if the vehicle has a low level of AdBlue® (UREA). Fill the AdBlue® (UREA) tank.



yellow amber

**REAR FOG LAMPS**

The warning light comes on when the rear fog lights are turned on.



yellow amber

**ESC-ASR SYSTEM / TRACTION PLUS FAILURE**

Flashing of the warning light while driving indicates the intervention of the ESC system. If the warning light does not go out or remains on whilst driving, go to a Fiat Dealership.

**CROSS WIND ASSIST SYSTEM INTERVENTION**

Flashing of the warning light while driving indicates the intervention of the Cross Wind Assist system. If the warning light does not go out or remains on whilst driving, go to a Fiat Dealership.

**HILL HOLDER SYSTEM FAILURE**

The warning light will turn on when the Hill Holder system is faulty. In this case, contact a Fiat Dealership as soon as possible.













yellow amber

**ESC-ASR / TRACTION PLUS SYSTEM DEACTIVATION**





The warning light comes on when the driver presses the ESC OFF button  or activates the Traction Plus function (for versions/markets, where provided).



|   | What it means  |
|---|--|
|  <p>yellow amber</p>                 | <p><b>START&amp;STOP SYSTEM MANUAL DEACTIVATION</b><br/>(for versions/markets, where provided)</p> <p>The warning light or symbol also appears on the display if the Start&amp;Stop system is deactivated.</p>   |
|  <p>yellow amber</p>                 | <p><b>LANE CONTROL SYSTEM FAILURE</b> (where provided)</p> <p>This warning light or symbol also appears on the display in the event of a Lane Control system failure. Contact a Fiat Dealership as soon as possible.</p>   |
|  <p>white / yellow amber / green</p> | <p><b>LANE CONTROL SYSTEM</b> (where provided)</p> <p>The warning light or the symbol in the display comes on as follows:<br/> <i>Warning light continuously on (white):</i> the system is activated, but the lane limits were not detected (the lane lines are grey).<br/> <i>Warning light on and flashing (amber):</i> the vehicle has approached the lane line and is about to pass it.<br/> <i>Warning light switched on continuously (green):</i> the system has detected the limits of both lanes. The system will act on the steering wheel if the lane was passed unintentionally.</p>  |
|  <p>yellow amber</p>                 | <p><b>TPMS</b><br/> <b>TPMS failure</b></p> <p>The warning light flashes for about 75 seconds and then stays on constantly to indicate that the system is temporarily deactivated or faulty.<br/> In this case, contact a Fiat Dealership as soon as possible.</p> <hr/> <p><b>Low tyre pressure</b></p> <p>The warning light turns on to indicate that the pressure of one or more tyres is lower than the recommended value and/or that slow pressure loss is occurring. In these circumstances, optimal tyre duration and fuel consumption may not be guaranteed.<br/> In this case it is advisable to restore the correct pressure value.</p> <p><b>WARNING</b> Do not continue driving with one or more flat tyres as vehicle handling may be compromised. Stop the vehicle, avoiding sharp braking and steering.</p> |





|   | What it means  |
|---|--|
|  <p>yellow amber</p> | <p>FULL BRAKE CONTROL SYSTEM TRIGGERED OR FAILURE<br/>(for versions/markets, where provided)</p> <p>The warning light or symbol also appears on the display if the system intervenes. The warning light or symbol appears if the system is not available.<br/>Contact a Fiat Dealership as soon as possible.</p>   |
|  <p>yellow amber</p> | <p>FULL BRAKE CONTROL SYSTEM MANUAL DEACTIVATION OR RESTARTING<br/>(for versions/markets, where provided)</p> <p>The warning light, or the symbol on the display, turns on with a fixed light if the system is deactivated manually, in case of the temporary blinding of the front camera or temporarily until the system itself is turned back on.</p> |
|  <p>green</p>        | <p>DIPPED BEAM headlamps<br/>The warning light switches on when the dipped beam headlamps are turned on.</p> <hr/> <p>FOLLOW ME HOME<br/>The warning light switches on when this device is in use (see explanations in "Follow me home device" paragraph in "External lights" in the "Knowing your vehicle" section).</p>                                |
|  <p>green</p>        | <p>LEFT DIRECTION INDICATOR<br/>The warning light switches on when the direction indicator stalk is moved downwards or, together with the right direction indicator, when the hazard warning light button is pressed.</p>  |
|  <p>green</p>        | <p>RIGHT DIRECTION INDICATOR<br/>The warning light switches on when the direction indicator stalk is moved upwards or, together with the left direction indicator, when the hazard warning light button is pressed.</p>  |
|  <p>green</p>        | <p>FOG LAMPS<br/>The warning light comes on when the front fog lights are turned on.</p>   |



|  | What it means   |
|--|---|
|  <p>green</p> | <p>CRUISE CONTROL<br/>(for versions/markets, where provided)</p> <p>This warning light switches on when the ignition key is turned to MAR, but it should switch off after a few seconds, if the Cruise Control is deactivated.</p> <p>The warning light in the instrument panel comes on when the Cruise Control system is engaged (press the button of the steering wheel controls to activate and then press one of the buttons of the steering wheel controls to set the speed).</p> |
|  <p>green</p> | <p>AUTOMATIC HIGH BEAM HEADLAMPS (Automatic High Beam / High Beam Control)</p> <p>This warning light comes on when the automatic main beam headlamps are activated.</p>   |
|  <p>green</p> | <p>TRACTION PLUS SYSTEM ACTIVATION<br/>(for versions/markets, where provided)</p> <p>This warning light or symbol also appears on the display in the event of a Traction Plus system activation.</p>  |
|  <p>blue</p>  | <p>HIGH BEAM HEADLIGHTS</p> <p>The warning light switches on when the high beam headlights are turned on.</p>   |



### IMPORTANT





- 56)** If when turning the key to MAR the warning light  does not turn on or stays on while driving, a fault may have occurred in the restraint systems. In this case the airbags or pretensioners may not be deployed in an accident or, in a lower number of cases, they may be deployed accidentally. Before continuing, contact a Fiat Dealership to have the system checked immediately.
- 57)** The failure of the  warning light is indicated by the  warning light flashing or, depending on the version, by the  icon constantly on in the display. In this case, the  warning light may not indicate a possible problem with the airbag restraint system. Before continuing, contact a Fiat Dealership to have the system checked immediately.











## WARNING









**20)** If, when the ignition key is turned to MAR, the warning light  does not switch on, switches on constantly or flashes while driving, contact a Fiat Dealership as soon as possible.

### Symbols shown on the display









| Symbol   | What it means   |
|--|---|
| <br>red | <b>AIRBAG FAILURE</b><br>The symbol switches on if there is an airbag system failure. Contact a Fiat Dealership as soon as possible.  |
| <br>red | <b>LOW ENGINE OIL PRESSURE</b><br>The symbol indicates that the engine oil pressure is low.<br>If it turns on temporarily or flashes (for about 5 seconds), check the oil level by following the corresponding procedure (see the description in the "Checking levels" chapter in the "Maintenance and care" section) and top up to the correct level if necessary.<br>If the symbol turns on continuously, contact a Fiat Dealership to have the system checked.<br><b>WARNING IF THE SYMBOL TURNS ON CONTINUOUSLY:</b> Do not use the vehicle until the failure has been solved.<br>When the symbol turns on, it does not indicate the amount of oil in the engine: the oil level can be checked on the display upon entering on the vehicle and also by activating the "Oil level" function on the Connect system.<br> <b>24)</b> |
| <br>red | <b>ALTERNATOR FAILURE</b><br>The switching on of the symbol with engine on corresponds to an alternator failure. Contact a Fiat Dealership as soon as possible.   |
| <br>red | <b>INCOMPLETE DOOR/LOAD COMPARTMENT CLOSURE</b><br>The symbol switches on when one or more doors or the load compartment are not completely shut. An acoustic signal will sound when doors/tailgate are open and the vehicle is moving.<br>An acoustic signal will sound when doors/tailgate are open and the vehicle is moving.<br>Close the door(s) or the load compartment correctly.  |









| Symbol   | What it means  |
|--|--|
| <br>red       | <p><b>BONNET NOT PROPERLY SHUT</b><br/>                     The symbol switches on when the engine bonnet is not properly shut (for versions/markets, where provided).<br/>                     Close the bonnet properly.</p>   |
| <br>red       | <p><b>AUTOMATIC TRANSMISSION FAILURE</b><br/>                     The symbol switches on, together with an acoustic warning, to indicate an automatic transmission or dual clutch automatic transmission failure. Contact a Fiat Dealership as soon as possible.</p> <p> 25)</p>  |
| <br>red       | <p><b>ATTENTION ASSIST SYSTEM INTERVENTION</b><br/>                     The symbol comes on in the event of a DAA (Driver Attention Assist) system intervention. The system, after estimating the driver's drowsiness level, through specific events, suggests to the driver to stop for a break, because continuing driving is risky. Stop to pause while driving, pulling the vehicle over in safe conditions.</p> |
| <br>red       | <p><b>SELF-LEVELLING SUSPENSION FAILURE (where provided)</b><br/>                     The symbol switches in the event of a failure in the self-levelling suspension system.<br/>                     Contact a Fiat Dealership.</p>   |
| <br>red/green | <p><b>SEAT BELTS</b><br/>                     the green symbol lights up when the seat belt is fastened correctly.<br/>                     the red symbol lights up when the seat belt is not fastened correctly. Always fasten the seat belt before setting off.</p>   |
| <br>amber     | <p><b>ATTENTION ASSIST SYSTEM INTERVENTION FAILURE</b><br/>                     The symbol comes on in the event of an Attention Assist system failure.<br/>                     Contact a Fiat Dealership.</p>  |
| <br>amber     | <p><b>BRAKE LIGHT FAILURE</b><br/>                     The symbol switches on in the case of failure of the brake lights.</p>  |
| <br>amber     | <p><b>BRAKE PAD WEAR</b><br/>                     The symbol switches on if the front or rear brake pads are worn.<br/>                     Replace the brake pads as soon as possible.</p>  |

| Symbol   | What it means   |
|--|---|
| <br>amber | <b>KEYLESS ENTRY SYSTEM FAILURE</b><br>The symbol comes on in the event of a Keyless Entry system failure.<br>Contact a Fiat Dealership as soon as possible.  |
| <br>amber | <b>ENGINE OIL PRESSURE SENSOR FAILURE</b><br>The symbol switches on in the event of engine oil level sensor failure.  |
| <br>amber | <b>RAIN SENSOR FAILURE</b><br>The symbol switches on in the case of failure of the rain sensor.<br>Contact a Fiat Dealership as soon as possible.   |
| <br>amber | <b>FUEL CUT-OFF SYSTEM OPERATION</b><br>The symbol switches on in the event of fuel cut-off system intervention.<br>For the fuel cut-off system re-activation procedure, see the "Fuel cut-off system" chapter in the "In an emergency" section. If it is still not possible to restore the fuel supply, contact a Fiat Dealership. |
| <br>amber | <b>FUEL CUT-OFF SYSTEM FAILURE</b><br>The symbol switches on in the event of fuel cut-off system failure.<br>Contact a Fiat Dealership as soon as possible.   |
| <br>amber | <b>FUEL FILTER (where provided)</b><br>The symbol switches on in the event of fuel filter failure.<br>Contact a Fiat Dealership as soon as possible.  |
| <br>amber | <b>START&amp;STOP SYSTEM FAILURE</b><br>The symbol switches on to report a failure of the Start&Stop system.<br>Contact a Fiat Dealership as soon as possible.  |
| <br>amber | <b>START&amp;STOP SYSTEM FAILURE / PRESS CLUTCH PEDAL</b><br>The symbol illuminates to indicate a fault in the Start&Stop system and alerts the driver to the need to press the clutch pedal.<br>Contact a Fiat Dealership as soon as possible.   |

















| Symbol   | What it means  |
|--|--|
| <br>amber         | <p><b>EXTERNAL LIGHTS FAILURE</b><br/>                     The symbol switches on to indicate a failure on the following lights: daytime running lights (DRL); parking lights; side lights; direction indicators; rear fog light; reversing light; number plate lights.<br/>                     The fault may be caused by a blown bulb, a blown protection fuse or an interruption of the electrical connection. Replace the faulty bulb. If the problem persists contact a Fiat Dealership.</p>   |
| <br>amber         | <p><b>FUEL LEVEL SENSOR FAILURE</b><br/>                     The symbol switches on in the event of fuel level sensor failure.<br/>                     Contact a Fiat Dealership.</p>   |
| <br>amber         | <p><b>WATER IN DIESEL FUEL FILTER</b><br/>                     The warning light or the symbol switches on fixed while driving to indicate the presence of water in the diesel filter.<br/>                     The presence of water in diesel fuel can cause severe engine damage. Please read the following warning carefully. More information on fuel quality can be found in the "Refuelling" table in the "Technical Specifications" section.  21)</p> |
| <br>amber         | <p><b>POSSIBLE ICE ON ROAD</b><br/>                     The symbol turns on when the external temperature falls to or below 3°C.<br/> <b>WARNING</b> In the event of external temperature sensor failure, the digits that indicate the value are replaced by dashes.</p>   |
| <br>amber         | <p><b>FIAT CODE SYSTEM FAILURE</b><br/>                     The symbol switches on to indicate a failure of the Fiat CODE system.<br/>                     Contact a Fiat Dealership as soon as possible.</p>  |
| <br>AUTO<br>amber | <p><b>DUSK SENSOR FAILURE</b><br/>                     The symbol switches on in the case of failure of the dusk sensor.<br/>                     Contact a Fiat Dealership as soon as possible.</p>   |
| <br>amber         | <p><b>SOUND SYSTEM FAILURE</b><br/>                     The symbol switches on to report a failure of the sound system.<br/>                     Contact a Fiat Dealership as soon as possible.</p>  |









| Symbol   | What it means  |
|--|--|
| <br>amber / red | <p><b>PARK ASSIST SYSTEM FAILURE</b></p> <p>The yellow symbol comes on in the event of a temporary Park Assist system failure. If the problem is still present after cleaning the parking sensor area, contact a Fiat Dealership.</p> <p>The red symbol comes on in the event of a permanent Park Assist system failure. The failed operation of the system might be due to the insufficient voltage from the battery or temporary interference or other failures on the electrical system. Contact a Fiat Dealership as soon as possible.</p> |
| <br>amber / red | <p><b>AUTONOMOUS EMERGENCY BRAKE CONTROL (AEB Control) SYSTEM FAILURE</b></p> <p>The yellow symbol switches on in the case of temporary failure of the Autonomous Emergency Brake Control (AEB Control) system. Contact a Fiat Dealership as soon as possible.</p> <p>The red symbol switches on in the case of permanent failure of the Autonomous Emergency Brake Control (AEB Control) system. Contact a Fiat Dealership as soon as possible.</p>   |
| <br>amber       | <p><b>BLIND SPOT ASSIST (BSA) SYSTEM FAILURE</b></p> <p>The symbol comes on in the event of a Blind Spot Assist system failure. Contact a Fiat Dealership as soon as possible.</p>   |
| <br>amber       | <p><b>TRAFFIC SIGN RECOGNITION SYSTEM FAILURE (where provided)</b></p> <p>The symbol comes on in the event of a Traffic Sign Recognition system failure. Contact a Fiat Dealership as soon as possible.</p>  |
| <br>white/grey  | <p><b>ADAPTIVE CRUISE CONTROL (ACC) (where provided)</b></p> <p>The white symbol lights up when Adaptive Cruise Control (ACC) is engaged and active.</p> <p>The grey symbol lights up when Adaptive Cruise Control (ACC) is engaged but not yet active.</p>  |
| <br>amber       | <p><b>ADAPTIVE CRUISE CONTROL (ACC) FAILURE (where provided)</b></p> <p>The symbol lights up to indicate a failure of the Adaptive Cruise Control (ACC) failure. Contact a Fiat Dealership as soon as possible.</p>  |











| Symbol   | What it means  |
|--|--|
| <br>amber | <p>SCHEDULED SERVICING (SERVICE)</p> <p>The "Service Schedule" includes vehicle maintenance at fixed intervals (refer to the "Maintenance and care" section).</p> <p>When the next scheduled service of the vehicle is approaching, the symbol will be displayed, followed by the number of kilometres/miles or days (where provided) left, when the ignition device is turned to MAR.</p> <p>This is displayed automatically, with ignition device at MAR, 2000 km before servicing or, where provided, 30 days before servicing. It is also displayed each time the ignition device is turned to MAR.</p> <p>The display will be in km or miles depending on the unit of measurement set. Go to a Fiat Dealership, where the "Scheduled Servicing Plan" work will be performed and the message will be reset.</p>  |
| <br>amber | <p>CLUTCH PEDAL</p> <p>The symbol lights up to indicate the need to press the clutch pedal to allow the engine to start for versions fitted with a manual transmission.</p>  |
| <br>amber | <p>DPF CLEANING (particulate trap) in progress (diesel versions with DPF only)</p> <p>The symbol switches on constantly to indicate that the DPF system needs to eliminate the trapped pollutants (particulate) through the regeneration process. <b>The symbol stays off during the entire DPF regeneration and lights up only when driving conditions require the driver to be notified.</b></p> <p>The symbol does not switch on during every DPF regeneration, but only when driving conditions require that the driver is notified. To turn off the symbol, keep vehicle in motion until the regeneration process is over. The process normally takes about 15 minutes. Optimum conditions for completing the process are achieved by travelling at 60 km/h with engine revs above 2000 rpm.</p> <p>When this symbol switches on, it does not indicate a defect of the vehicle and thus it should not be taken to a workshop.</p> <p><b>WARNING Failure to follow the procedure provided for when the symbol comes on for a mileage equal to or greater than 30 km or for a cumulative time equal to or greater than 2 hours, may result in the warning light  coming on with consequent damage to the DPF device. Remember that if the warning light  is on, it is necessary to go to the Fiat Dealership to restore the correct operation of the DPF.</b></p> |
| <br>amber | <p>AUTOMATIC HIGH BEAM HEADLIGHTS FAILURE</p> <p>The symbol switches on to report a failure of the automatic high beam headlights.</p> <p>Contact a Fiat Dealership as soon as possible.</p>   |



| Symbol  | What it means   |
|---|---|
| <br>amber  | HILL DESCENT CONTROL (where provided)<br>The symbol appears to indicate that the Hill Holder system has intervened.   |
| <br>amber  | DEGRADED ENGINE OIL (where provided)<br>The symbol is shown on the display. The symbol is displayed for 3 minute cycles and intervals of 5 seconds until oil is changed. The symbol is displayed until the problem is solved.<br>WARNING After the first indication, each time the engine is started the symbol will continue to switch on as described above until the oil is changed.<br>If the symbol flashes, this does not mean that there is a defect on the vehicle, rather it simply reports that it is now necessary to change the oil as a result of regular use of the vehicle. The deterioration of engine oil is accelerated by using the vehicle for short drives, preventing the engine from reaching operating temperature. Contact a Fiat Dealership as soon as possible.<br> 22) 23) |
| <br>amber  | SPEED LIMITER FAILURE<br>The symbol switches on to indicate a Speed Limiter failure.<br>Contact a Fiat Dealership as soon as possible.  |
| <br>amber  | TRAILER LENGTH ("AUTO" SETTING)<br>The symbol lights up to show the trailer length, set via the "Blind Spot" function in the Setup Menu of the display. The length can be: 3 metres, or 6 metres, or 9 metres(or 10 ft, 20 ft, 30 ft depending on the selected unit of measure).  |
| <br>amber  | MAXIMUM TRAILER LENGTH<br>The symbol lights up to indicate the maximum length (greater than 9 metres) of the trailer, set using the "Blind Spot" function in the Setup Menu of the display.   |
| <br>amber  | AUTOMATIC TRAILER LENGTH<br>The symbol lights up to show the automatic trailer length, set via the "Blind Spot" function in the Setup Menu of the display.  |
| <br>amber | FUEL CUT-OFF CIRCUIT BREAKER OF THE ADDITIONAL HEATER TRIPPED (where provided)<br>The symbol turns on to indicate that the fuel cut-off circuit breaker of the additional heater has tripped. See the information in the "In an emergency" section of the "Fuel cut-off circuit breaker of the additional heater" chapter.  |



| Symbol  | What it means  |
|---|--|
| <br>amber        | <p>GENERIC FAILURE WARNING (where provided)<br/>                     The symbol lights up in the following circumstances:</p> <ul style="list-style-type: none"> <li><input type="checkbox"/> if the fuel cut-off inertia switch is activated;</li> <li><input type="checkbox"/> light failure (rear fog lamps, direction indicators, brake lights, number plate light, side lights, daytime running lights, automatic high beam headlights, trailer direction indicators, trailer side lights). The fault relating to these lights could be: one or more blown bulbs, a blown protection fuse or a break in the electrical connection;</li> <li><input type="checkbox"/> airbag warning light failure (generic failure warning light flashing). In this case, the warning light (or symbol) may not indicate any faults with the restraint systems. Before continuing, contact a Fiat Dealership to have the system checked immediately.</li> <li><input type="checkbox"/> rain sensor failure / trailer connection failure / sound system failure / parking sensors failure. In these cases, contact a Fiat Dealership as soon as possible to have the fault fixed.</li> </ul> |
| <br>LIM<br>green | <p>INTELLIGENT SPEED ASSIST SYSTEM ACTIVATION (where provided)<br/>                     The symbol comes on in the event of a Intelligent Speed Assist system failure.</p>   |
| <br>green        | <p>ELECTRONIC CRUISE CONTROL<br/>                     The symbol comes on in the event of a Cruise Control system failure.</p>   |
| <p><b>LIM</b><br/>                     green</p>  | <p>SPEED LIMITER<br/>                     The symbol comes on in the event of a Speed Limiter system failure.</p>  |
| <br>green        | <p>MANUAL START&amp;STOP ACTIVATION<br/>                     The activation of the system is indicated by the turning on of symbol.</p> <hr/> <p>START&amp;STOP SYSTEM ACTIVATION<br/>                     The symbol appears in the case of Start&amp;Stop (engine switching off) intervention. Restarting the engine, the warning light switches off.</p>  |
| <br>white        | <p>HEADLIGHT HEIGHT<br/>                     The symbol indicates the height of the dipped beam headlights, set to four levels (0-4) using buttons  and .</p>  |



| Symbol  | What it means   |
|---|---|
| <br>or<br><br>white | <p>SINGLE GEAR SHIFT INDICATION (SHIFTING UP)<br/>           This symbol appears to suggest engaging a higher gear (upshifting).<br/>           NOTE The symbol graphics will vary according to the type of display fitted on your vehicle.</p>   |
| <br>or<br><br>white | <p>SINGLE GEAR SHIFT INDICATION (SHIFTING DOWN)<br/>           The symbol appears to suggest engaging a lower gear (downshifting).<br/>           NOTE The symbol graphics will vary according to the type of display fitted on your vehicle.</p>   |
| <br>or<br><br>white | <p>DOUBLE GEAR SHIFT INDICATION (SHIFTING UP)<br/>           This symbol appears to suggest shifting two gears up (upshifting).<br/>           NOTE The symbol graphics will vary according to the type of display fitted on your vehicle.</p>  |
| <br>or<br><br>white | <p>DOUBLE GEAR SHIFT INDICATION (SHIFTING DOWN)<br/>           The symbol appears to suggest shifting down two gears (downshifting).<br/>           NOTE The symbol graphics will vary according to the type of display fitted on your vehicle.</p>   |
| <br>white  | <p>HILL DESCENT CONTROL (where provided)<br/> <i>System enabling:</i> turning on of the symbol with a fixed light.<br/> <i>System activation failed:</i> LED on the button in the central tunnel comes on (see the description in the "Safety" section of the "Active Safety Systems" chapter).</p> |



| Symbol   | What it means   |
|--|---|
| <br>white / red | <b>SPEED LIMIT EXCEEDED</b><br>The symbol turns on when the speed limit (e.g. 120 km/h) set through the display from Menu is exceeded (the inner value updates according to the set speed).<br>In markets where provided, the speed limit is fixed and cannot be set from the Menu. |
| <b>LIM</b><br>white/grey   | <b>SPEED LIMITER</b><br>The white symbol appears to indicate that the Speed Limiter is ready.<br>The grey symbol appears to indicate that the Speed Limiter is ready.   |
| <br>white       | <b>TOWING A TRAILER</b><br>The symbol lights up when a trailer is coupled to the vehicle.   |
| <br>white       | <b>TRAILER TOWING FAILURE</b><br>The symbol switches on to report a failure of the trailer system.<br>Contact a Fiat Dealership as soon as possible.  |
| <b>ECO</b><br>white  | <b>"DRIVE MODE" FUNCTION</b> (versions with manual transmission)<br>The message appears on the display if the "ECO" function is activated.  |
| <b>ECO</b><br>or<br><b>PWR</b><br>white  | <b>"DRIVE MODE" FUNCTION</b> (versions with automatic transmission)<br>The messages are shown on the display when the "ECO" or "POWER" function is activated.   |



### WARNING

- 21)** The presence of water in the fuel system circuit may cause severe damage to the injection system and irregular engine operation. If the  symbol is displayed contact a Dealership as soon as possible to bleed the system. If the warning appears immediately after refuelling, water has probably entered the tank. In this case, switch the engine off immediately and contact a Dealership.
- 22)** Degraded engine oil should be replaced as soon as possible after the warning light  comes on, and never more than 500 km after it first comes on. Failure to observe the above may result in severe damage to the engine and invalidate the warranty. **Remember that when this warning light comes on, it does not mean that the level of engine oil is low, so if it flashes it does not mean that you need to top up the engine oil.**

**23)** If the warning light flashes when driving, contact a Fiat Dealership.



### WARNING

**24)** If the  symbol switches on while driving, stop the engine immediately and contact a Fiat Dealership.

**25)** Driving the vehicle with this symbol on may severely damage the transmission, with resulting breakage. The oil may also overheat: contact with hot engine or with exhaust components at high temperature could cause fires.



# SAFETY

*The section that you are about to read is very important: it describes the safety systems with which the vehicle is equipped and provides instructions on how to use them correctly.*

|   |     |
|---|-----|
| ABS .....   | 115 |
| ESC (Electronic Stability Control)<br>SYSTEM .....              | 116 |
| TRACTION PLUS SYSTEM .....                                      | 119 |
| DRIVING ASSISTANCE<br>SYSTEMS .....                             | 120 |
| OCCUPANT PROTECTION<br>SYSTEMS .....                            | 131 |
| SEAT BELTS .....  | 132 |
| SBR (SEAT BELT REMINDER)<br>SYSTEM .....                        | 133 |
| PRE-TENSIONERS .....  | 135 |
| CHILD RESTRAINT SYSTEMS .....                                   | 136 |
| SETUP FOR "UNIVERSAL<br>ISOFIX" CHILD RESTRAINT<br>SYSTEM ..... | 141 |
| SUPPLEMENTARY RESTRAINT<br>SYSTEM (SRS) - AIRBAG .....          | 150 |



## ABS

This is an integral part of the braking system, which prevents one or more wheels from locking and slipping regardless of the road surface conditions and braking intensity, ensuring control of the vehicle even during emergency braking.

The system intervenes during braking when the wheels are about to lock, typically in emergency braking or low-grip conditions, when locking may be more frequent.

The ABS ensures the direction of the vehicle while braking and optimises the braking distances at the same time.

The system also improves control and stability of the vehicle when braking on a surface on which the grip of the left and right wheels differs, or when braking while cornering.

The system is completed by EBD (Electronic Braking Force Distribution), which distributes the braking action between the front and rear wheels.

**WARNING** To obtain the maximum efficiency of the braking system, a bedding-in period of about 500 km is needed: during this period it is better to avoid sharp, repeated and prolonged braking.



58)

### SYSTEM INTERVENTION

The driver can feel that the ABS has come into action because the brake pedal pulsates slightly and the system gets noisier: it means that the vehicle speed should be altered to suit the type of road surface.



59) 60) 61) 62) 63) 64) 65)

### MSR SYSTEM

#### (Motor Schleppmoment Regelung)

This is an integral part of the ABS system and prevents the drive wheels from locking, which could happen, for example, if the accelerator pedal is released suddenly or in the case of shifting down suddenly in conditions of poor grip. In these conditions, the engine braking effect could cause the drive wheels to slip, resulting in a loss of vehicle stability. In these situations, the system intervenes, restoring torque to the engine in order to conserve vehicle stability and increase safety.



### IMPORTANT

**58)** *The ABS gets the most from the available grip, but it cannot improve it; you should therefore take every care when driving on slippery surfaces and not take unnecessary risks.*

**59)** *When the ABS cuts in and you feel the brake pedal pulsating, do not remove your foot, but keep the pedal pushed down; in doing so you, will stop in the shortest distance possible under the road conditions at the time.*

**60)** *If the ABS intervenes, this indicates that the grip of the tyres on the road is nearing its limit: you must slow down to a speed compatible with the available grip.*

**61)** *The ABS cannot overrule the natural laws of physics, and cannot increase the grip available according to the condition of the road.*

**62)** *The ABS system cannot prevent accidents, including those due to excessive speed on corners, driving on low-grip surfaces or aquaplaning.*

**63)** *The capability of the ABS must never be tested irresponsibly and dangerously, in such a way as to compromise personal safety and the safety of others.*

**64)** *For the correct operation of the ABS, the tyres must of necessity be the same make and type on all wheels, in perfect condition and, above all, of the prescribed type and dimensions.*

**65)** *If the spare wheel (for versions/markets, where provided) is used, the ABS keeps operating. Always remember that the spare wheel, being smaller than the original wheel, provides less grip.*



## ESC (Electronic Stability Control) SYSTEM

(for versions/markets, where provided)

The ESC system improves the directional control and stability of the vehicle in various driving conditions.

The ESC system corrects understeer and oversteer, distributing the brake force on the appropriate wheels. The torque supplied by the engine can also be reduced in order to maintain control of the vehicle.

The ESC system uses the sensors in the vehicle to determine the trajectory required by the driver through steering and compares it with the real trajectory of the vehicle.

When the real trajectory deviates from the desired trajectory, the ESC system intervenes to counter understeer or oversteer.

Oversteer: occurs when the vehicle is turning more than it should according to the angle of the steering wheel.

Understeer: occurs when the vehicle is turning less than it should according to the angle of the steering wheel.

The ESC system also includes the following subsystems:

Hill Holder

- ASR
- HBA
- ERM
- HDC

 66) 67) 68)

### SYSTEM INTERVENTION

This is signalled by the flashing of the warning light  in the instrument panel, to inform the driver that the vehicle is in critical stability and grip conditions.

### SYSTEM ACTIVATION

The ESC system switches on automatically when the engine is started and cannot be switched off.

### HILL HOLDER SYSTEM

This system is an integral part of the ESC system and facilitates starting on slopes.

It is automatically activated in the following conditions:

uphill: vehicle stationary on a road with a gradient higher than 5%, engine running, brake pressed and gearbox in neutral or gear (other than reverse) engaged;

downhill: vehicle stationary on a road with a gradient higher than 5%, engine running, brake pressed and reverse gear engaged.

When setting off, the ESC system control unit maintains the braking pressure on the wheels until the torque

necessary for starting is reached, or in any case for a maximum of 2 seconds, allowing your right foot to be moved easily from the brake pedal to the accelerator.

When the 2 seconds have elapsed, without starting, the system is automatically deactivated, gradually releasing the braking pressure.

During this release stage, the typical mechanical brake release noise indicating that the vehicle is going to move imminently will be heard.

**WARNING** The Hill Holder system is not a parking brake; therefore, never leave the vehicle without having engaged the parking brake, turned the engine off and engaged 1<sup>st</sup> gear, so that it is parked in safe conditions (for further information read the "Parking" chapter in the "Starting and driving" section).

### ASR (AntiSlip Regulation) SYSTEM

It is an integral part of the ESC system. It automatically operates in the event of one or both drive wheels slipping, loss of grip on wet roads (aquaplaning) and acceleration on slippery, snowy or icy roads, etc.

Depending on the slipping conditions, two different control systems are activated:

- if the slipping involves both drive wheels, the ASR intervenes reducing the power transmitted by the engine;
- if the slipping only involves one of the drive wheels, it intervenes automatically braking the wheel that is slipping.



### Engagement/ disengagement of the ASR system

The ASR system switches on automatically each time the engine is started.

While driving, the ASR can be switched off and subsequently switched on again by pressing the ESC OFF  (A) fig. 161 button.

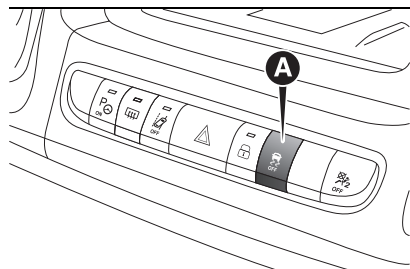

161

F1A0709

If the ASR is disengaged during driving, it is automatically reactivated when the vehicle is next started.

When travelling on snowy roads with snow chains, it may be helpful to turn the ASR off: in fact, in these conditions, the driving wheels skidding when moving off gives you better traction.

### HBA (Hydraulic Brake Assist) SYSTEM

The HBA system is designed to improve the braking capacity of the vehicle during emergency braking. The system detects an emergency braking by monitoring the speed and strength with which the brake pedal is pressed, thereby applying the optimal brake pressure.

This can reduce the braking distance: the HBA system therefore completes the ABS.

Maximum assistance from the HBA system is obtained pressing the brake pedal very quickly. In addition, the brake pedal must be pressed continuously during braking, avoiding intermittent presses, to benefit from the system.

Do not reduce pressure on the brake pedal until braking is no longer necessary.

The HBA system is deactivated when the brake pedal is released.

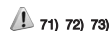

### ERM (ELECTRONIC ROLLOVER MITIGATION) SYSTEM

The system monitors the tendency of the wheels to rise from the ground if the driver performs extreme manoeuvres like quick steering to avoid an obstacle, especially in poor road conditions.

If these conditions occur, the system intervenes on the brakes and engine power to reduce the possibility that the wheels are raised from the ground.

It is not possible to avoid the tendency to roll over if this is due to reasons such as driving on high side gradients, collision with objects or other vehicles.



### HDC (Hill Descent Control) SYSTEM

It is an integral part of the ESC and is aimed at keeping the vehicle at a constant speed during a descent, operating autonomously on the brakes in various ways at the same time. In this way the vehicle stability and completely safe driving are guaranteed, above all in poor grip conditions and/or steep descents.

To activate the system, reach a speed slower than 25 km/h and press the corresponding button (A)fig. 162; the



LED on the button turns on and the display shows a dedicated message.

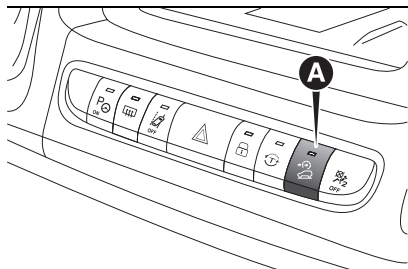

162

F1A0644

After reaching the desired speed, release the accelerator and brake pedals completely (the LED on the button flashes). If you want to increase/decrease the speed, press the accelerator/brake pedals again.

**WARNING** Do not use the device with the gearbox in neutral position.

**WARNING** It is important to engage a gear suitable for the set speed, to prevent the engine from stalling.

When this function is active the brake lights turn on automatically. While the HDC system is operating it is also possible to take control of the vehicle again by pressing the brake and accelerator pedals.

If the function is not made available when the button is pressed, this could be due to brake overheating. In this case, wait a few minutes before using the function again.

**WARNING** The system is available for speeds below 25 km/h.

**WARNING** On exceeding 25 km/h, the HDC system is disabled and remains ready to operate again (the LED on the button remains on) when the vehicle returns below 25 km/h. If the vehicle speed exceeds 40 km/h, the HDC system turns off completely (the LED on the button turns off) and any autonomous action on the brakes is disabled.

To reactivate it, press the dedicated button again when the speed is again below 25 km/h.



### IMPORTANT

**66)** *The ESC system cannot overrule the natural laws of physics, and can't increase the grip available according to the condition of the road.*

**67)** *The ESC system cannot prevent accidents, including those due to*

*excessive speed on corners, driving on low-grip surfaces or aquaplaning.*

**68)** *The capability of the ESC system must never be tested irresponsibly and dangerously, in such a way as to compromise personal safety and the safety of others.*

**69)** *For the correct operation of the ESC and ASR systems it is vital that the tyres are the same make and the same type on all the wheels, in perfect condition and, above all, the recommended type and size.*

**70)** *The performance of the ESC and ASR systems must not encourage the driver to take unnecessary risks. Driving style must always be suitable for road conditions, visibility and traffic. The driver is, in any case, responsible for safe driving.*

**71)** *The HBA system cannot increase tyre grip on the road over the limits imposed by laws of physics: always drive carefully according to the conditions of the road surface.*

**72)** *The HBA system cannot prevent accidents, including those due to excessive speed on bends, travelling on low-grip surfaces or aquaplaning.*

**73)** *The HBA system is an aid for the driver, who must always pay full attention while driving. The responsibility always rests with the driver. The features of the HBA system must never be tested in imprudent or dangerous ways, with the possibility of putting the safety of the driver, occupants or other road users at risk.*

**74)** *The performance of a vehicle with ERM must never be tested in imprudent or dangerous ways, with the possibility*

of putting the safety of the driver or other people at risk.



## WARNING

**26)** Prolonged use of the system may overheat the braking system. If the brakes overheat, the HDC system, when active, will be gradually deactivated after suitably informing the driver (the LED on the button turns off): it can be reactivated only when the brakes have cooled sufficiently. The distance you can travel depends on the brake temperature and thus on the slope, the load and the vehicle speed.

## TRACTION PLUS SYSTEM

(for versions/markets, where provided) Traction Plus is a driving aid, useful for setting off in poor grip conditions on non-homogeneous road surfaces (snow/asphalt, ice/asphalt, mud/asphalt, etc.), which allows the drive force to be distributed adequately on the engine axle when one of the two drive wheels slips.

Traction Plus acts by braking the wheel with poor grip (or the one which slips more than the others), thereby transferring the drive force to those which have greater grip on the ground. This function can be turned on manually by pressing the (A) button

fig. 163 on the dashboard and works below a level of 50 km/h. Over this speed, it is automatically deactivated (the LED on the button is still on) and it is reactivated again when the speed is below 30 km/h.



75) 76)

## TRACTION PLUS OPERATION

When the engine is started the system is disabled.

To activate the "Traction Plus" system, press the button (A) fig. 163: the LED on the button switches on.

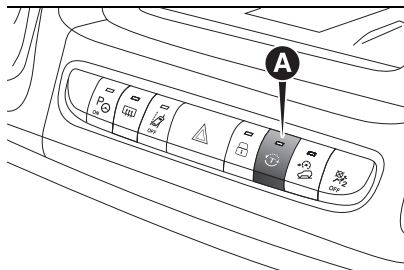

163

F1A0645

The activation of the Traction Plus system involves the following functions being switched on:

- inhibition of the ASR function, in order to fully exploit the engine torque;
- the differential locking effect on the front axle, through the braking

system, to improve traction on irregular grounds.

If the "Traction Plus" system is faulty, the "general failure" instrument panel warning light  comes on steady.

When travelling on snowy roads with snow chains, it may be helpful to turn the Traction Plus on and thus inhibiting the ASR function: in fact, in these conditions, slipping of the drive wheels when moving off makes it possible to obtain better traction.



## IMPORTANT

**75)** The Traction Plus system acts effectively only on road surfaces that are not homogeneous and/or differentiated between the two drive wheels.

**76)** Until the setting off manoeuvre is terminated, fully press the accelerator pedal to transfer the appropriate drive torque to the wheel with the best grip.



## DRIVING ASSISTANCE SYSTEMS

The vehicle may be fitted with the following driving assistance systems:

- BSA (Blind Spot Assist with Trailer Detection)
- Attention Assist
- TPMS (Tyre Pressure Monitoring System)
- AEBC (Autonomous Emergency Brake Control)
- Lane Control
- Cross Wind Assist (CWA)

For the operation of the systems, refer to the following pages.

### BSA (Blind Spot Assist with Trailer Detection) SYSTEM

The vehicle can be equipped with the BSA (Blind Spot Assist with Trailer Detection) system for blind spot monitoring. The BSA system uses two radar sensors, located in the rear side bumper (one on each side) fig. 164, to detect the presence of vehicles (cars, trucks, etc.) in blind spots in the rear side zone of the vehicle, while driving on the road and while reversing (RCP functionality).

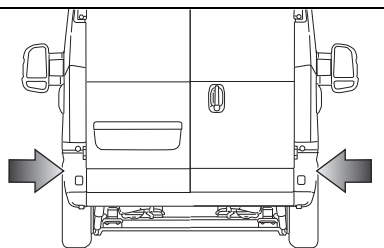

164

F1A0480

The system warns the driver about the presence of vehicles in the detection area by lighting up, on the relevant side, the warning light located on the door mirror, along with an acoustic warning. When the vehicle is started the warning light turns on to signal the driver that the system is active.

#### Sensors

The sensors are activated when any forward gear is engaged at a speed higher than about 10 km/h, or when reverse is engaged.

The sensors are temporarily deactivated with vehicle at a standstill and the gear lever in position P (Park) (versions with automatic transmission), or with vehicle at a standstill and parking brake engaged (versions with manual transmission).

In no trailers are connected, the detection area of the system covers

about a lane on both sides of the vehicle (approx. 3 metres).

Such zone begins near the centre pillar of the vehicle and extends up to 6 metres from the rear of the vehicle.

When the sensors are active the system monitors the detection areas on both sides of the vehicle and warns the driver about the possible presence of cars in these areas.

While driving the system monitors the detection area from three different input points (side, rear and front) to check whether a signal needs to be sent to the driver.

#### WARNINGS

- The system does not signal the presence of fixed object (e.g. safety barriers, poles, walls, etc.). However, in some circumstances, the system may activate in the presence of these objects. This is normal and does not indicate a system malfunction.
- The system does not warn the driver about the presence of vehicles coming from the opposite direction, in the adjacent lanes.
- For the system to operate correctly, the side rear bumper area fig. 164 where the radar sensors are located must stay free from snow, ice and dirt gathered from the road surface.

❑ Do not cover the side rear bumper area fig. 164 where the radar sensors are located with any object (e.g. adhesives, bike rack, etc.).

### Rear view

The system detects vehicles coming from the rear part of the vehicle on both sides and entering the rear detection area fig. 165 with a difference in speed of less than 50 km/h with respect to your vehicle.

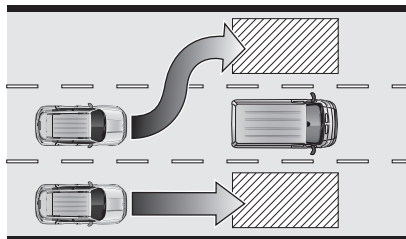

165

F1A0482

### Overtaking vehicles

If another vehicle is overtaken slowly fig. 166 (with a difference in speed of less than about 25 km/h), the warning light on the door mirror of the corresponding side lights up. If the difference in speed between the two vehicles is greater than about 25 km/h, the warning light does not light up.

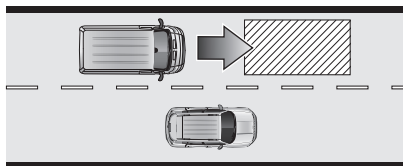

166

F1A0481

### RCP (Rear Cross Path detection) function

This system helps the driver during reverse manoeuvres. The RCP system detects objects moving towards both rear sides of the vehicle at a speed of between 5 km/h and 60 km/h, as is generally the case in parking lots fig. 167.

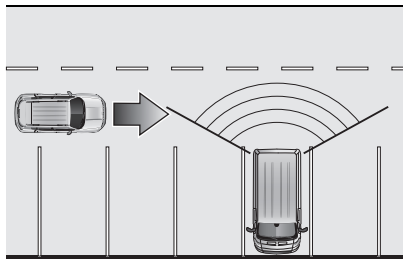

167



F1A0484

The system activation is signalled to the driver by means of a visual and acoustic warning.

WARNING If the detection field of sensors are covered by objects or vehicles, the system will not warn the driver.

### BSA operation method

The system can be activated/deactivated by operating on the display Menu, or via the **Uconnect™** system (for further information see the dedicated supplement).

To turn the system on/off using the display menu, access the Setup Menu by pressing the MODE button on the dashboard and scroll through the list of settings using the  or  buttons. Select "Blind Spot". The available methods are:

- OFF
- DISPLAY
- SOUND & DISPLAY

### Blind Spot Assist "Visual" mode

When this mode is active, the BSA system sends a visual warning to the respective door mirror on the side of the detected obstacle.

However, when the RCP function is on, the system produces acoustic





and visual warnings when an object is detected.

When an acoustic warning is sent, the volume of the radio is lowered.

### **Blind Spot Assist "Sound & Display" mode**

When this mode is active, the BSA system sends a visual warning to the respective door mirror on the side of the detected obstacle.

If the direction indicator on the side where an obstacle has been detected is activated, an acoustic warning is emitted as well.

The volume of the radio is not turned down.

During "RCP" operating mode, the system emits acoustic and visual indications if the presence of an object is detected. When an acoustic warning is sent the volume of the radio is also turned down.

### **"Blind Spot Assist" system deactivation**

When the system is deactivated ("Blind Spot" function set to "OFF" on the instrument panel), the BSA or RCP systems will not emit either acoustic nor visual warnings.

The BSA system will store the operating mode running when the engine was stopped. Each time the car is started the previously stored mode will be recalled and used.



77

### **Trailer Detection**

The system can detect the presence and length of a trailer and extend the blind spot warning zone to the length of the trailer.

After the system detects the presence of a trailer and the speed exceeds 10 km/h, a notification is sent to driver.

#### If a trailer is detected, the Rear Cross Path function is deactivated.

The "Blind Spot" function on the display Setup Menu can be used to set the mode for detecting the trailer length.

According to the set trailer length detection mode, the corresponding icon will be displayed:

with the "Max" setting selected.

The warning zone is set to the maximum expected length (greater than 9 metres);

, or with the "Auto"

setting selected. The system will show an icon corresponding to the automatically detected length (3 m, 6 m, 9 m). In this case, it may be necessary to travel at least a curve with a 90-degree rotation to let the system detect the length of the trailer. Once the length has been determined, the icon corresponding to the length measured in metres or feet will be

displayed depending on the selected unit of measurement.

If the trailer exceeds a length of 9 m, the system displays the icon corresponding to the maximum length. If the vehicle is stationary for more than 120 seconds, the system detects the trailer again:

if the trailer is no longer detected, the icon indicating the presence and length of the trailer disappears;

when set to "Auto", if a new trailer is detected as present, with the same length as the previous one (with an error of 1 m), the length icon remains unchanged;

When set to "Auto", if a new trailer is detected as present, with a different length from the previous one, the length icon is updated.



### **IMPORTANT**

**77)** *The system is an aid for driving the vehicle, it DOES NOT warn the driver about incoming vehicles outside of the detection areas. The driver must always maintain a sufficient level of attention to the traffic and road conditions and for controlling the trajectory of the vehicle.*



## ATTENTION ASSIST SYSTEM

(where provided)

This is an auxiliary driving assistance system that detects when the driver is tired.

### ACTIVATION / DEACTIVATION

The system can be activated/deactivated via the "Settings" menu of the **Uconnect™** system (see "Settings" in the "Vehicle mode" paragraph in the "Multimedia" section) or via the instrument panel (see "Settings" in the "Display" chapter in the "Knowing the instrument panel" section).

### SYSTEM INTERVENTION

The system intervenes if the camera in the middle of the windscreen fig. 168 detects that the driver is tired, based on variations of vehicle trajectory and getting too close to the side of the road.

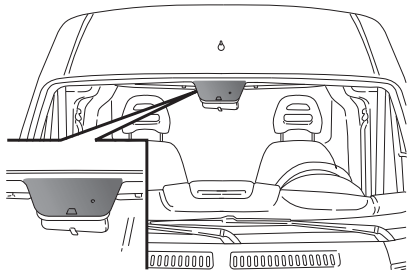



168

F1A0998

The (red)  symbol appears on the instrument panel screen with a dedicated message suggesting the driver to stop and take a break. An acoustic warning is also emitted.

❑ If the driver **accepts** the suggestion provided by the system and stops for a pause, by pressing the OK button on the left side of the steering wheel, the message will disappear from the display and the symbol  will be displayed in the dedicated area of the instrument panel display up to the next time the engine is started/stopped.

❑ If the driver **ignores** the warning provided by the system and does not stop, the message will remain on the instrument panel display until the **OK** button located on the left hand side controls of the steering wheel is pressed. The symbol  will remain displayed in the dedicated area of the instrument panel display.

**IMPORTANT** In the event of a system fault, the amber symbol  appears on the instrument panel display.

## TPMS (Tyre Pressure Monitoring System)

(for versions/markets, where provided)

 78) 79) 80) 81) 82) 83) 84) 85) 86)

### DESCRIPTION

The tyre pressure monitoring system

(TPMS) warns the driver of low tyre pressure on the basis of the cold inflation pressure prescribed for the vehicle.

Changes in external temperature may cause tyre pressure to vary. This means that a decrease in the external temperature corresponds to a decrease in the tyre pressure.

Tyre pressure must always be adjusted according to the cold inflation pressure. Cold tyre inflation pressure is the tyre pressure after letting the vehicle stand for at least three hours or a travel shorter than 1.6 km after an interval of three hours.

The cold tyre inflation pressure must not exceed the maximum inflation pressure value printed on the side of the tyre.

The tyre pressure also increases while driving the vehicle: this is a normal condition and does not require any adjustment of the pressure.

The TPMS continues to advise the driver of the low tyre pressure condition until this is corrected; the warning continues until the pressure corresponds or exceeds the pressure prescribed for the cold tyres. When the low tyre pressure check warning light  turns on continuously, the



inflation pressure must be adjusted until it reaches the pressure prescribed for cold tyres. After the automatic update of the system, the tyre pressure control warning light switches off. You may need to drive the vehicle for about 20 minutes at a speed higher than 20 km/h to allow the TPMS to receive this information.

### NOTE

- ❑ The TPMS does not replace the normal tyre maintenance service and does not indicate any fault in a tyre.
- ❑ Therefore, the TPMS should not be used as pressure switch while adjusting the tyre inflation pressure.
- ❑ Driving with insufficient tyre pressure causes their overheating and can result in tyre failure. The low inflation pressure reduces fuel efficiency and tyre tread life and may also affect handling and braking performance of the vehicle.
- ❑ The TPMS does not replace the correct tyre maintenance. It is up to the driver to maintain the correct tyre pressure level measuring it with a suitable pressure switch. This is necessary even if the decrease in the inflation pressure value does not cause the tyre pressure control warning light to switch on.
- ❑ The TPMS warns the driver of any condition of insufficient tyre pressure. If this drops below the insufficient

pressure limit for any reason including low temperature and normal pressure loss of the tyre.

- ❑ The seasonal temperature changes affect tyre pressure.

The TPMS uses wireless devices with electronic sensors mounted on the wheel rims to constantly monitor the value of tyre pressure. The sensors mounted on each wheel as part of the valve stem transmit various information of the tyres to the receiver module, in order to calculate the pressure.

**WARNING** Monitoring and maintaining the correct pressure in all four tyres are particularly important.

### Tyre pressure monitoring system low pressure warnings

The system warns the driver if one or more tyres are flat by turning on the (⚠) warning light on the instrument panel (together with an acoustic warning).

In this case, stop the vehicle as soon as possible, check the inflation pressure of each tyre and inflate to the cold tyre pressure value prescribed for the vehicle. The system will automatically update and after receiving the tyre pressure update the tyre pressure control warning light switches off. You may need to drive the vehicle for about 20 minutes at a

speed higher than 20 km/h to allow the system to receive this information.

### TPMS operation faults

The system fault is indicated by the corresponding warning light (⚠), which first flashes for 75 seconds and then stays on continuously. This can occur in any of the following situations:

- ❑ interference caused by electronic devices or radio frequency emissions similar to those of the TPMS sensors.
- ❑ Application of tinted films which interfere with the signals of the radio waves.
- ❑ Presence of snow or ice on the wheels or the wheel arches.
- ❑ Use of snow chains.
- ❑ Use of wheels/tyres not equipped with TPMS sensors.
- ❑ The spare wheel is not equipped with the tyre pressure control sensor. Therefore, the tyre pressure is not controlled by the system.
- ❑ If the spare wheel replaces a tyre with a pressure lower than the insufficient pressure limit, an acoustic warning will be emitted and the (⚠) warning light will turn on at the next start-up.
- ❑ When the original tyres is repaired or replaced and it is mounted back on the vehicle to replace the spare wheel, the TPMS will update automatically and the warning light will switch off,

provided that the pressure of none of the four tyres is below the insufficient pressure limit. If the vehicle has been stopped with the engine off for at least 20 minutes, you may need to drive the vehicle for about 20 minutes at a speed higher than 20 km/h to allow the TPMS to receive this information.



## IMPORTANT

**78)** The TPMS is optimised for the original tyres and wheels provided. TPMS pressures and alerts have been defined according to the size of the tyres mounted on the vehicle. Using equipment with different size, type or kind may cause irregular system operation or sensor damage. Non-original spare wheels can damage the sensor. Do not use tyre sealant or balancing weights if the vehicle is equipped with TPMS as these may damage the sensors.

**79)** If the system signals a pressure drop on a specific tyre, it is recommended to check the pressure on all four tyres.

**80)** The TPMS does not relieve the driver from the obligation to check the tyre pressure every month; it is not even to be considered a replacing system for maintenance or a safety system.

**81)** Tyre pressure must be checked with tyres cold. Should it become necessary for whatever reason to check pressure with warm tyres, do not reduce pressure even though it is higher than the prescribed

value, but repeat the check when tyres are cold.

**82)** The TPMS cannot indicate sudden tyre pressure drops (for example when a tyre bursts). In this case, stop the car, braking with caution and avoiding abrupt steering.

**83)** The system only warns that the tyre pressure is low: it is not able to inflate them.

**84)** Insufficient tyre inflation increases fuel consumption, reduces the tread duration and may affect your ability to drive the vehicle safely.

**85)** Always refit the valve stem cap after inspecting or adjusting tyre pressure. This prevents dampness or dirt from entering the valve stem and thus the pressure control sensor from being damaged.

**86)** The Tire Repair Kit provided with the vehicle (for versions/markets, where provided) is compatible with the TPMS sensors; using sealants not equivalent with that in the original kit may adversely affect its operation. If sealants not equivalent with the original one are used, it is recommended to have the TPMS sensor operation checked by a qualified repair centre.

## AUTONOMOUS EMERGENCY BRAKE CONTROL SYSTEM (AEB Control)

(where provided)

 **87) 88) 89) 90) 91)**

 **27) 28) 29) 30) 31)**

This is a driving assistance system consisting of a camera mounted in

the middle of the windscreen fig. 169 capable of intervening in case of vehicles, cyclists and pedestrians. In the event of an imminent collision the system intervenes by automatically braking the vehicle to prevent the impact or reduce its effects.

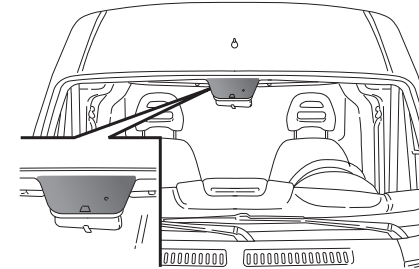

169

F1A0988

The system provides the driver with audible and visual signals through specific messages on the instrument panel display.

The warnings are intended to allow the driver to react promptly, in order to prevent or reduce the effects of a potential accident.

In situations with the risk of collision, if the system detects no intervention by the driver, it provides automatic braking to help slow the vehicle and mitigate the potential frontal accident (automatic braking).

If intervention by the driver on of the brake pedal is detected but



not deemed sufficient, the system may intervene in order to improve the reaction of the braking system, therefore reducing vehicle speed further (additional assistance in braking stage). The system will not intervene if the driver takes control of the vehicle and is recognised as being aware of the situation and possible collision. The vehicle is equipped with the "creeping" function. It may therefore restart a few seconds after the automatic stop in the case of vehicles with automatic transmission. If braking brings the vehicle to a stop the engine may stall on vehicles with manual transmission.

**WARNING** After the vehicle is stopped, the brake callipers may be locked for about 2 seconds for safety reasons. Make sure you press the brake pedal if the vehicle moves slightly forwards.

### Engagement / disengagement

The Autonomous Emergency Brake Control can be deactivated (and then switched back on again) using the **Uconnect™** system (see "Settings" in the "Vehicle mode" paragraph in the "Multimedia" section), or using the instrument panel (see "Settings" in the "Display" chapter in the "Knowing the instrument panel" section).

The system can be turned off even with the ignition device in MAR position. The system can be set to two activation levels:

- ☐ *System active*: the system (if active), in addition to the visual and acoustic warnings, provides automatic braking and additional assistance in braking stage, where the driver does not brake sufficiently in the event of a potential frontal impact;
- ☐ *System deactivated*: the system does not give visual and acoustic warnings, limited braking, automatic braking or additional assistance during braking. The system will therefore provide no indication of a possible accident.

**WARNING** Visual signals will indicate the direction of detection of the obstacle (vehicles, pedestrians or cyclists).

### Activation / deactivation

If Autonomous Emergency Brake Control has been correctly activated, it will be active each time the engine is started.

The system is deactivated if this is selected on the instrument panel or **Uconnect™** system menu. Following a deactivation, the system will not warn the driver about the

possible accident with the preceding vehicle, regardless of the setting selected.

The system activation status will not be kept in the memory when the engine is switched off: if the system is deactivated when the engine is switched off, it will be active when it is next started.

After a deactivation, the system can be reactivated from the **Uconnect™** system or instrument panel menu. The function is not active at speed below 5 km/h.

The system is only active if:

- ☐ it has been activated correctly;
- ☐ it has not been deactivated using the instrument panel or **Uconnect™** system menu;
- ☐ the ignition device is at MAR;
- ☐ the vehicle speed is greater than 5 km/h.

### Changing the system sensitivity

The sensitivity of the system can be changed through the **Uconnect™** system or instrument panel menu, choosing from one of the following three options: "Near", "Med" or "Far". See the description in the "Multimedia" section for how to change the settings. The default option is "Med". With this setting, the system warns the driver of a possible collision with the vehicle in front when that vehicle is at a standard

distance, between that of the other two settings. This setting offers the driver reaction time longer than that of the "Near" setting but shorter than that of the "Far" setting in the event of a potential accident.

By setting system sensitivity to "Near", the system warns the driver of a possible accident with the vehicle in front when that vehicle is a short distance away.

With the system sensitivity set to "Far", the system will warn the driver of a possible collision with the vehicle in front when that vehicle is at a greater distance, thus providing the possibility of acting on the brakes more lightly and gradually. This setting provides the drivers with the maximum possible reaction time to prevent a potential accident.

The system sensitivity setting is kept in the memory when the engine is switched off.

### **Function temporarily not available warning**

If the deactivation warning light comes on together with the failure warning lights without having intentionally deactivated the system, a condition temporarily disabling operation of the system may have occurred. The main possible causes of this temporary blinding may be weather-related (heavy

rain, fog, sun low down on the horizon, etc.).

Although the vehicle can still be driven in normal conditions, the system may be temporarily not available.

When the conditions limiting the system functions end, this will go back to normal and complete operation.

Should the fault persist, contact a Fiat Dealership.

### **Warning of system disabling due to an obstruction**

If the dedicated message is displayed, a condition disabling operation of the system may have occurred. The possible cause of this disabling is a camera obstruction. If an obstruction is signalled, clean the area of the windscreen indicated in fig. 169 and check that the message has disappeared. Although the vehicle can still be driven in normal conditions, the system is not available.

When the conditions disabling the system functions end, it will return to normal and complete operation. Should the fault persist, contact a Fiat Dealership.

### **System Fault Message**

If the system switches off and a dedicated message is shown on the display, it means that there is a fault on the system.

In this case, it is still possible to drive the vehicle, but you are advised to contact a Fiat Dealership as soon as possible.

### **Driving in special conditions**

In certain driving conditions, such as, for example:

- driving close to a bend;
- vehicles with small dimensions and/or not aligned in the driving lane;
- lane change by other vehicles;
- vehicles travelling at right angles to the vehicle.

System intervention might be unexpected or delayed. The driver must therefore be very careful, keeping control of the vehicle to drive in complete safety.

**WARNING** In particularly complex traffic conditions, the driver can deactivate the system manually through the **Uconnect™** system or the instrument panel.

### **Driving close to a bend**

When entering or leaving a wide bend, the system may detect a vehicle that is in front of you, but that is not driving in the same lane fig. 170. In cases such as these, the system may intervene.

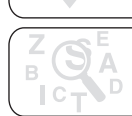

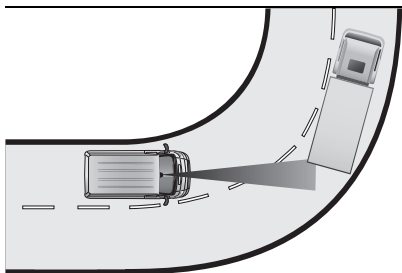

170

F1A0997

### Vehicles with small dimensions and/or not aligned in the driving lane

The system cannot detect vehicles in front of you but outside the camera's field of vision and may therefore not react in the presence of small vehicles, such as motorbikes. fig. 171.

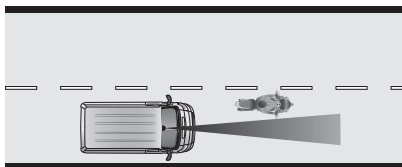

171

F1A0996

### Pedestrian/cyclist detection

While driving, when there is a risk of collision with a pedestrian or cyclist, the

system will display the relevant warning message indicating the direction of obstacle detection and, if necessary, apply the brakes.

### Lane change by other vehicles

Vehicles suddenly changing lane, entering the same lane as your vehicle and this moving into the camera's field of vision, may cause the system to intervene fig. 172.

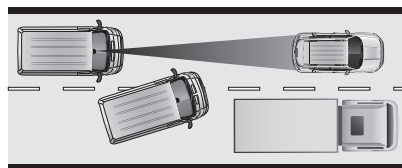

172

F1A0995

### Warnings

The system has not been designed to prevent impacts and cannot detect possible conditions leading to an accident in advance. Failure to take into account this warning may lead to serious or fatal injuries.

In case of complex scenarios, unexpected or unnecessary warnings or braking may occur.



### IMPORTANT

**87)** The system is an aid for the driver, who must always pay full attention while driving. The responsibility always rests with the driver, who must take into account the traffic conditions in order to drive in complete safety. The driver must always maintain a safe distance from the vehicle in front.

**88)** The capability of the Autonomous Emergency Brake Control system must never be tested irresponsibly or dangerously, in such a way as to compromise personal safety and the safety of others.

**89)** If the driver presses the accelerator pedal fully or steers abruptly during system operation, the automatic braking function may stop (e.g. to allow a possible manoeuvre to avoid the obstacle).

**90)** The system intervenes on vehicles, pedestrians and cyclists travelling in the same lane. Animals and things (e.g. pushchairs) are not taken into consideration.

**91)** If the car must be placed on a roller bench for maintenance or if it is washed in an automatic car wash with an obstacle in the front part (e.g. another vehicle, a wall or another obstacle), the system may detect its presence and activate. Therefore, in this case the system must be deactivated.



 **WARNING**

**27)** The system may have limited operation or not work at all in weather conditions such as, low sun, heavy rain, hail, thick fog, heavy snow.

**28)** System intervention might be unexpected or delayed when other vehicles transport loads projecting from the side, above or from the rear, with respect to the normal size of the vehicle.

**29)** Operation can be adversely affected by any structural change made to the car, such as a modification to the front geometry, tyre change, or a heavier load than the standard load of the car.

**30)** Incorrect repairs in the zone where the camera is mounted may interfere with its field of vision and reduce its performance (e.g. application of fillers or glues to remove scratches). Go to a Fiat Dealership for any operation of this type.

**31)** Do not tamper with nor operate on the camera on the windscreen. In the event of a sensor failure, contact a Fiat Dealership.

## LANE CONTROL SYSTEM DESCRIPTION

The Lane Control makes use of a camera located on the windscreen to detect the lane limits and calculate the position of the vehicle within such limits to make sure that it remains inside the lane.

When the one of the lane lines is detected and the vehicle crosses it without the awareness of the driver

(direction indicator off), the Lane Control system provides a tactile warning in form of torque applied to the steering wheel (vibration) when the lane limit is approached, thus advising the driver that action must be taken to remain in the lane.

**WARNING** The torque applied to the steering wheel by the system is sufficient for the driver to notice it, but always limited, so that they can easily override it, and the driver always maintains control of the vehicle. The driver can therefore turn the steering wheel as required at all times.

If the vehicle continues going beyond the line of the lane without any intervention from the driver, the warning light  (or the icon on the reconfigurable multifunction display) will be displayed on the instrument panel to urge the driver to bring the vehicle back into the limits of the lane.

### SYSTEM ON/OFF

When the vehicle is started the system is disabled.

To disengage the system press button (A) fig. 173.

On some versions, a specific message indicating disabling is shown on the display.

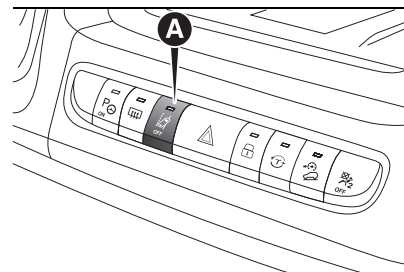

173

F1A0648

### Activation conditions

Once switched on, the system becomes active only if the following conditions are met:

- the driver always keeps at least one hand on the steering wheel;
- vehicle ranges between 60 km/h and 180 km/h;
- the lane is delimited at least on one side;
- there are suitable visibility conditions;
- the road is straight or with wide radius bends;
- the direction indicator (lane departure) is not activated in the same lane departure direction as the vehicle.

**WARNING** The system does not apply torque to the steering wheel every time a safety system is activated (brakes, ABS, ASR system, ESC system, Forward Collision Warning Plus system, etc.).



## SYMBOLS AND MESSAGES ON THE DISPLAY

The Lane Control system also warns the driver when the vehicle strays out of lane by displaying symbols on the instrument panel display.

### Versions with analogue display

When the system is active and the lane limits have not been detected, the symbol  is fixed and white.

### Versions with reconfigurable multifunction display

When the system is active and the lane limits have not been detected, the lane lines are grey and a dedicated icon is shown in the dedicated top area of the display.

### Exiting a lane with detection of a single limit

When the system is active and only, for example, the left lane limit has been detected, a vehicle icon is shown in the dedicated area of the display; the system is ready to provide visual warnings in the event of unintentional exiting (direction indicator not activated) of the lane to the left.

When the system detects that the vehicle has approached the lane line, the left line on the display turns yellow and the vehicle icon shown on the display becomes yellow.

When the system detects that the vehicle has approached the lane line

and is about to pass it, the left line on the display (yellow) flashes and the vehicle icon shown on the display turns yellow.

The system operates in the same way, but mirrored, in the event of exiting the right lane when only the right lane limit has been detected.

### Exiting a lane with detection of both limits

When the system is active, the lane lines on the display become white to indicate the successful detection of the limits.

When both lane limits have been detected, the vehicle shown in the graphic icon on the display changes green and the system is ready. In accordance with the different conditions detected, the system can attract the attention of the driver by altering the lines that identify the lanes on the display. In particular, the system can alter their colour (from white to yellow and vice versa), and make them flash. Equally, the system alters the colour of the vehicle icon shown on the display.

### Changing the system settings

The settings of the system can be changed through the **Uconnect™** system (see description in the dedicated supplement).

## System limited operation warning



If the dedicated message is shown on the display, a condition limiting the system operation may have occurred. The possible reasons of this limitation are something blocking the camera view or a fault.

If an obstruction is signalled, clean the area of the windscreen by the interior rear-view mirror and check that the message has disappeared.

Although the vehicle can still be driven in normal conditions, the system may be not completely available.

When the conditions limiting the system functions end, this will go back to normal and complete operation. Should the fault persist, contact a Fiat Dealership.

### No hands on steering wheel detection

If the system detects no hands from the steering wheel during active system intervention, the system will produce an escalation of visual-acoustic warnings, which will take 15 seconds to invite the driver to put the hands on the steering wheel. If you do not put your hands on the wheel within this time, the system will disconnect and provide an additional warning for 5 seconds.



## System Fault Message

If the system switches off and a dedicated message is shown on the display, it means that there is a fault on the system.

In this case, it is still possible to drive the vehicle, but you are advised to contact a Fiat Dealership as soon as possible.



### WARNING

**32)** The camera may have limited or absent operation due to weather conditions such as: heavy rain, hail, thick fog, heavy snow, formation of ice layers on the windscreen glass.

**33)** Camera operation may also be compromised by the presence of dust, condensation, dirt or ice on the windscreen glass, by traffic conditions (e.g. vehicles that are driving not aligned with yours, or vehicle in a transverse or opposite way on the same lane, bend with a narrow radius of curvature), by road surface conditions and by driving conditions (e.g. off-road driving). Make sure the windscreen is always clean. Use specific detergents and clean cloths to avoid scratching the windscreen. The camera operation may also be limited or absent in some driving, traffic and road surface conditions.

## CROSS WIND ASSIST (CWA) SYSTEM

The Cross Wind Assist (CWA) system helps the driver stabilise the vehicle in the event of a strong or short crosswind when travelling on a straight line (fig. 174).

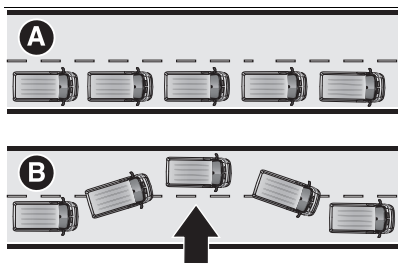

174

F1A9081

(A) With Cross Wind Assist

(B) Without Cross Wind Assist

Activation of the CWA system depends on the following conditions:

- vehicle speed
- estimated wind force
- road conditions (bumps and aquaplaning)

The sidewise swaying of the vehicle caused by side wind force is minimised by the active braking generated by the ESC system.

Activation of the CWA system is indicated by the warning light  turning on.

Activation of the CWA system causes deactivation of the Electronic Cruise Control and Adaptive Cruise Control for safety reasons.

## OCCUPANT PROTECTION SYSTEMS

Some of the most important safety equipment of the vehicle comprises the following protection systems:

- seat belts;
- SBR (Seat Belt Reminder) system;
- head restraints;
- child restraint systems;
- Front airbags and side bags.

Read the information given the following pages with the utmost care. It is of fundamental importance that the protection systems are used in the correct way to guarantee the maximum possible safety level for the driver and the passengers.

For the description of the head restraint adjustment, see the "Head restraints" chapter in the "Knowing your vehicle" section.



## SEAT BELTS

### IN BRIEF

*All the seats in the vehicle are equipped with seat belts with three anchoring points and a retractor. The reel mechanism operates locking the belt in the event of sharp braking or strong deceleration due to an impact. This allows the belt strap to slide freely and to adapt to the body of the occupant. In the event of an accident, the belt will lock to reduce the risk of impact inside the passenger compartment or of being projected outside the vehicle. The driver is responsible for respecting, and ensuring that all the other occupants of the vehicle also respect, the local laws in force in relation to the use of the seat belts. Always fasten the seat belts before setting off.*

### USING THE SEAT BELTS

The belt should be worn keeping the torso straight and rested against the backrest.

To fasten the seat belts, hold fastening tongue (A) fig. 175 and insert it into buckle (B), until it clicks into place.

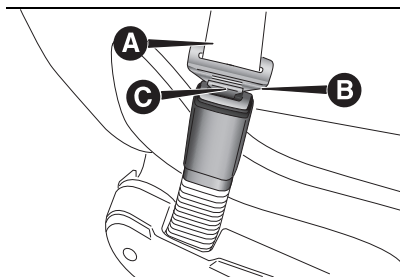

175

F1A0145

On removal, if the belt jams, let it rewind for a short stretch, then pull it out again without jerking.

Press button (C) fig. 175 to release the belt. Guide the belt while it is rewinding to prevent it from twisting.

The retractor may lock up when the vehicle is parked on a steep slope: this is perfectly normal.

Furthermore, the reel mechanism locks the belt if it is pulled sharply or in the event of sudden braking, collisions and high-speed bends.



### HEIGHT ADJUSTMENT

To adjust, press button (A) fig. 176 and raise or lower the handle (B).



Always adjust the seat belt height to the passenger's body. This precaution may considerably reduce the risk of injury in the event of a collision.

Correct adjustment is obtained when the belt passes approximately half way between the shoulder and the neck.

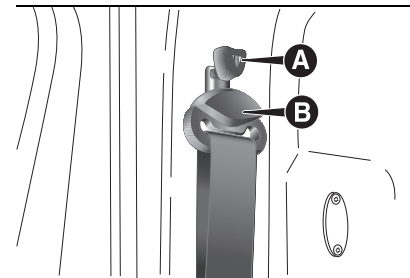

176

F1A0146

### Seat belt with retractor for front central place on bench seat

The two-seater front bench is equipped with an on-board seat belt (reel on seat) with three anchorage points for the central position fig. 177.

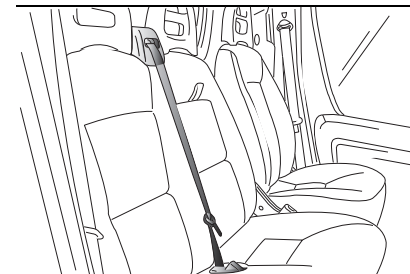

177

F1A0147

**IMPORTANT**

- 92)** Never press button (C) fig. 175 when travelling.
- 93)** Make height adjustment of the seat belts when the car is stationary.
- 94)** After adjustment, always check that the cursor to which the ring is fastened is locked in one of the preset positions. To do this, with button released, press downward more to allow the anchoring device to click if it has not been released in one of the possible positions.

**SBR (SEAT BELT REMINDER) SYSTEM**

The SBR system warns the passengers of the front and rear (where provided) seats if their seat belt is not fastened. The system warnings unfastened seat belts with visual warnings (warning lights on in the instrument panel and icons on the display) and an acoustic warning (see the following paragraphs). NOTE To deactivate the horn permanently contact a Fiat Dealership. The horn can be reactivated at any time through the display Menu (see the "Display" chapter in the "Knowing the instrument panel" section).

**Front seat belt warning light operation**

When the ignition device is turned to MAR, the warning light (A) fig. 178

(3.5" display) or fig. 179 (7" display) for comes on for a few seconds, regardless of the status of the front seat belts.

With the vehicle moving slower than 20 km/h, if the driver side seat belt or the passenger side seat belt (with occupant seated) is unfastened, the warning light (A) stays on constantly.

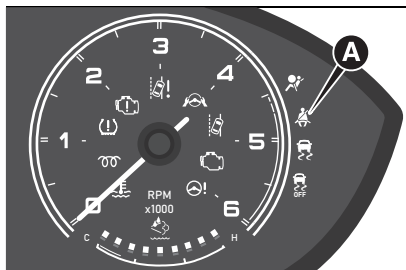

178 F1A0846



179 F1A0846

As soon as a speed threshold of 20 km/h is reached, with driver side seat belt or the passenger side seat

belt (with occupant seated) unfastened, an acoustic warning is activated simultaneously with warning light (A) flashing for about 105 seconds.

Once activated, this warning cycle stays active for the entire time if the vehicle is moving faster than 8 km/h or if reverse gear is not engaged or until the seat belts are fastened.

When the reverse is engaged, during the cycle of warnings, the acoustic signal is deactivated and the (A) warning light turns on fixed.

If the vehicle speed drops to less than 8 km/h or if reverse gear is engaged during the warning cycle, the acoustic warning will be deactivated and the warning light switches on fixed.





If the entire time has not elapsed and reverse gear is not engaged, the warning cycle is reactivated as soon as the vehicle speed exceeds 20 km/h again.

**Operation of rear seat belt icons**

The icons shown on the display fig. 180 (3.5" display) or fig. 181 (7" display) according to the corresponding seat belts in the rear seats, and stay on for about 65 seconds from the last seat belt status change.

The icons (A) shown on the display indicate:



- three symbols : left, centre, right seat;
- four symbols : left, centre left, centre right, right seat(Cargo versions);
- three symbols  for the middle row: left, middle, right seat and three symbols  for the third row: left, middle, right seat (Panorama version).

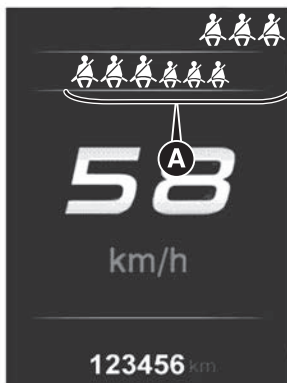

180

F1A0847





181

F1A0848

### Icons on the 3.5" display

If a rear seat belt is fastened, the icon  appears.

With the vehicle travelling at a speed lower than 20 km/h, if a rear seat belt is unbuckled, the icon  stays on with fixed light for a total of approximately 65 seconds.



If the vehicle is travelling at a speed faster than 20 km/h and reverse gear is not engaged, if a rear seat belt is unbuckled, an acoustic indication is sounded when the icon  flashes for approximately 35 seconds.

Successively, the acoustic warning is deactivated and the icon lights up with fixed light until the end of the entire cycle.

### Icons on the 7" display

The icons are displayed according to the corresponding seat belts in the rear seats, and stay on for about 65

seconds from the last seat belt status change:

- if the seat belt is fastened the corresponding icon  will be green;
- if the seat belt is unfastened the corresponding icon  will be red.

With the vehicle travelling at speed lower than 20 km/h, if a rear seat belt is unfastened, the red icon  stays on with fixed red light for a total of approximately 65 seconds.

If the vehicle is travelling at a speed faster than 20 km/h and reverse gear is not engaged, if a rear seat belt is unbuckled, an acoustic warning is sounded when the red icon  flashes for approximately 35 seconds. Successively, the acoustic warning is deactivated and the icon lights up with fixed light until the end of the entire cycle.

Furthermore, the icons lights up for a few seconds whenever one of the rear doors is opened.

### WARNINGS

As far as the rear seats and the third row are concerned, the SBR system will only indicate whether the seat belts are unfastened or fastened, not the presence of any passengers.

For the rear seats and on the third row, the icons will activate a few seconds after the ignition device has been turned to MAR, regardless of the status

of the seat belts (even if the seat belts are all fastened).

All the warning lights/icons will come on when at least one belt changes from fastened to unfastened status or vice versa.

## **PRE-TENSIONERS**

To increase the protective efficiency of the front seat belts, the vehicle is fitted with pretensioners. These devices, in the event of a head-on crash or side impact, rewind the seat belts a few centimetres. In this way, they ensure that the belts fit tightly to the wearer before the restraining action begins. It is evident that the pretensioners have been activated when the belt withdraws toward the retractor.

A slight discharge of smoke may be produced during the activation of the pretensioner which is not harmful and does not involve any fire hazard. The pretensioner does not require any maintenance or lubrication.

Any changes to its original conditions will invalidate its efficiency. If, due to unusual natural events (floods, sea storms, etc.), the device has been affected by water or mud, contact a Fiat Dealership to have it replaced.



95)



34)

**WARNING** To obtain the highest degree of protection from the action of the pretensioner, wear the seat belt tight to the chest and pelvis.

## **LOAD LIMITERS**

To increase passenger safety, the front seat belt retractors contain a load limiter which controls the force acting on the chest and shoulders during the belt restraining action in the event of a head-on collision. This device is present on all versions with the exception of the version with bench seat if no air bag is present.

## **GENERAL INSTRUCTIONS FOR USING THE SEAT BELTS**

Seat belts are also to be worn by pregnant women: the risk of injury in the case of accident is greatly reduced for them and the unborn child if they are wearing a seat belt. Pregnant women must position the lower part of the belt very low down so that it passes over the pelvis and under the abdomen (see fig. 182).

While pregnancy progresses, the driver must adjust both the seat and the steering wheel to ensure full control of the vehicle (pedals and steering wheel must be easily accessible). The maximum clearance should be kept

between the abdomen and the steering wheel. The seat belt strap must not be twisted. The upper part must pass over the shoulder and cross the chest diagonally. The lower part must adhere to the pelvis fig. 183, not to the abdomen of the occupant. Do not use devices (clips, etc.) to hold the seat belt away from your body.



182



F1A0148



183

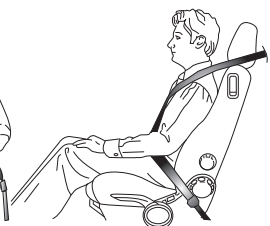

F1A0149



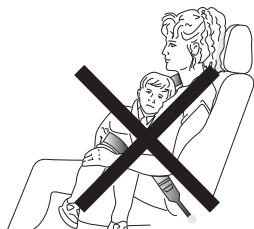

184

F1A0150

Each seat belt must be used by only one person. Never travel with a child sitting on the passenger's lap and a single belt to protect them both fig. 184. In general, do not place any objects between the person and the belt.

## SEAT BELTS MAINTENANCE

For keeping the seat belts in efficient conditions, carefully observe the following warnings:

- always use the seat belt well stretched and never twisted; make sure that it is free to run without obstructions;
- check seat belt operation as follows: attach the seat belt and pull it hard;
- replace the belt after an accident of a certain severity even if it does not appear to be damaged. Always replace

the belt if the pretensioners were deployed;

- prevent the retractors from getting wet: their correct operation is only guaranteed if water does not get inside;
- replace the seat belt when it shows wear or cuts.



## IMPORTANT

**95)** *The pretensioner may be used only once. After it is triggered, have it replaced at a Fiat Dealership.*

**96)** *For maximum safety, keep the backrest upright, lean back into it and make sure the seat belt fits closely across your chest and pelvis. Always fasten the seat belts on both the front and the rear seats! Travelling without wearing seat belts will increase the risk of serious injury and even death in the event of an accident.*

**97)** *Removing or tampering with seat belt and pretensioner components is strictly prohibited. Any intervention on these components must be performed by qualified and authorised technicians. Always go to a Fiat Dealership.*

**98)** *If the belt has been sharply pulled, for example as the result of an accident, the seat belt, together with the anchoring devices, the anchoring device fixing screws and the pretensioner must be completely replaced. Even if the belt does not present any exterior signs of wear or damage, it may have lost its restraining properties.*



## WARNING

**34)** *Operations which lead to impacts, vibrations or localised heating (over 100°C for a maximum of six hours) in the area around the pretensioners may damage or deploy them. Contact a Fiat Dealership should intervention be necessary on these components.*

## CHILD RESTRAINT SYSTEMS

### CARRYING CHILDREN SAFELY

For optimal protection in the event of an impact, all occupants must be seated and wearing adequate restraint systems, including newborn and other children! This prescription is compulsory in all EC countries according to EC Directive 2003/20/EC. Children below the height of 1.50 metres and up to 12 years must be protected with suitable restraint systems and be seated on the rear seats. Statistics on accidents indicate that the rear seats offer greater safety for children. Compared with adults, a child's head is proportionally larger and heavier than the rest of the body, while muscles and bone structure are not fully developed. Therefore, correct restraint systems other than adult seat

belts are necessary, to reduce as much as possible the risk of injuries in the event of an accident, braking or sudden manoeuvre. Children must be seated safely and comfortably.

As far as the characteristics of the child seats used allow, you are advised to keep children in rearward facing child seats for as long as possible (at least until 3–4 years old), since this is the most protected position in the event of a collision. The choice of the most suitable child restraint system depends on the weight and size of the child.

There are various types of child restraint systems that can be secured to the vehicle by means of the seat belts or with the ISOFIX anchorages. It is recommended to always choose the restraint system most suitable for the child; for this reason always refer to the Owner Handbook provided with the child restraint system, to be sure that it is of the right type for the children it is intended for.

In Europe the characteristics of child restraint systems are ruled by the regulation ECE-R44, dividing them into five weight groups:

| Group   | Weight groups         |
|---------|-----------------------|
| Group 0 | up to 10 kg in weight |

| Group    | Weight groups         |
|----------|-----------------------|
| Group 0+ | up to 13 kg in weight |
| Group 1  | 9-18 kg               |
| Group 2  | 15 - 25 kg            |
| Group 3  | 22 - 36 kg            |

As you can see, the groups overlap partly and, in fact, there are devices on sale that cover more than one weight group.

All restraint devices must bear the type-approval data, together with the control mark, on a label solidly fixed to the child restraint system which must never be removed.

Over 1.50 m in height, from the point of view of restraint systems, children are considered as adults and wear the seat belts normally.

Lineaccessori MOPAR includes child restraint systems for each weight group. These devices are recommended, having been specifically designed for Fiat cars.



### GROUP 0 and 0+

Babies up to 13 kg must be carried facing backwards on a cradle seat, which, supporting the head, does not induce stress on the neck in the event of sharp decelerations.

The cradle is restrained by the seat belts of the vehicle, as shown in fig. 185 and it must restrain the child in turn with its own belts.

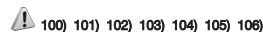

### 0-13 kg

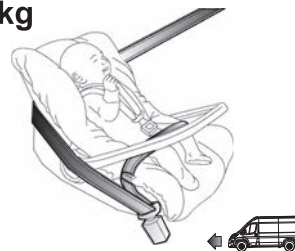

185

F1A0151

### GROUP 1

Children from 9 kg to 18 kg in weight can be carried facing forwards if the child seat is fitted with a front cushion, through which the vehicle seat belt restrains both child and seat fig. 186.



### 9-18 kg

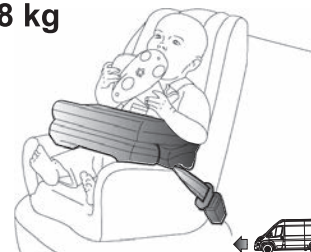

186

F1A0152





**GROUP 2**

Children from 15 to 25 kg may use the seat belts of the vehicle directly fig. 187.

The child restraint system is now needed only to position the child correctly with respect to the belts so that the diagonal section crosses the child's chest and never the neck, and the lower part is snug on the pelvis not the abdomen.

 101) 102) 103) 104) 105)

**15-25 kg**

187

F1A0153

**GROUP 3**

For children from 22 kg to 36 kg in weight the size of the child's chest no longer requires a support to space the child's back from the backrest.

The fig. 188 shows the correct child positioning on the rear seat.

 101) 102) 103) 104) 105)

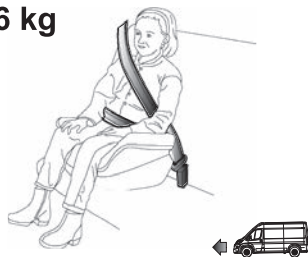
**22-36 kg**

188

F1A0154

Children over 1.50 m in height can wear seat belts like adults.

**IMPORTANT**

**99)** Do not place a rear-facing cradle seat on the front seat if the passenger side airbag is enabled. Deployment of the airbag in an accident could cause fatal injuries to the child regardless of the severity of the impact. It is advisable to always carry children in a child restraint system on the rear seat, which is the most protected position in the event of a collision. If you need to carry a child on the front passenger seat in a rear-facing cradle restraint system, the passenger side airbags (front and side bags for chest/pelvis protection, for versions/markets, where provided) must be deactivated using the setup menu. It is important to check the dedicated LED on button  on the dashboard to make sure that they are actually deactivated. Move the passenger's seat as far back

as possible to avoid contact between the child seat and the dashboard.

**100)** On the sun visor there is a label with suitable symbols reminding the user that it is compulsory to deactivate the airbag if a rearward facing child restraint system is fitted. Always comply with the instructions on the passenger side sun visor (see the "Supplementary Restraint System (SRS) - Airbag" chapter).

**101)** Do not move the front or rear seat if a child is seated on it or on the dedicated child restraint system.

**102)** Incorrect fitting of the child restraint system may result in an inefficient protection system. In the event of an accident the child restraint system may become loose and the child may be injured, even fatally. When fitting a restraint system for newborns or children, strictly comply with the instructions provided by the Manufacturer.

**103)** When the child restraint system is not used, secure it with the seat belt or with the ISOFIX anchorages, or remove it from the vehicle. Do not leave it unsecured inside the passenger compartment. In this way, in the event of sudden braking or an accident, it will not cause injuries to the occupants.

**104)** Always make sure that the diagonal section of the seat belt does not pass under the arms or behind the back of the child. In the event of an accident the seat belt will not be able to secure the child, with the risk of injury, including fatal injury. Therefore the child must always wear the seat belt correctly.

**105)** The diagrams are indicative and provided for assembly purposes only. Fit



*the child restraint system according to the instructions, which must be included.*

**106)** *Car seats for weight groups 0 and 1 feature an anchor in front of the vehicle safety belts as well as its own belts to restrain the child. Due to their weight, they may be dangerous if incorrectly mounted (e.g. if fastened to the vehicle seat belts placing a cushion in between). Follow the assembly instructions carefully.*



## PASSENGER SEAT COMPLIANCE FOR USING UNIVERSAL CHILD SEATS

The vehicle complies with the new European Directive 2000/3/EC which governs the arrangement possibilities for child restraint systems on the seats of a vehicle as shown in the following table (the table refers to the single cab Van, Combi and Panorama versions):

| Group       | Weight groups | CAB            |                 |                |                 | 1st and 2nd REAR SEATS ROW |                           |                        |
|-------------|---------------|----------------|-----------------|----------------|-----------------|----------------------------|---------------------------|------------------------|
|             |               | Single seat    |                 | Double seat    |                 | Rear left side passenger   | Rear right side passenger | Rear central passenger |
|             |               | Airbag enabled | Airbag disabled | Airbag enabled | Airbag disabled |                            |                           |                        |
| Group 0, 0+ | Up to 13 kg   | X              | U               | X              | X               | U                          | U                         | X                      |
| Group 1     | 9–18 kg       | X              | U (a)           | X              | X               | U                          | U                         | X                      |
| Group 2     | 15–25 kg      | U (a)          | U (a)           | X              | X               | U                          | U                         | X                      |
| Group 3     | 22–36 kg      | U (a)          | U (a)           | X              | X               | U                          | U                         | X                      |

(\*) IMPORTANT: NEVER fit rearward-facing child restraint systems on the front seat with an active passenger airbag. If you wish to fit a rearward-facing child seat in the front passenger seat, first deactivate the relative airbag (see instructions in the "Supplementary Restraint System (SRS) – Airbag" chapter).

X restraint system not suitable for children in this weight category.

U suitable for child restraint systems of the "Universal" category, according to European Standard ECE-R44 for the specified "Groups".

(a) forward facing child restraint system, the seat must be positioned no more forward than the longitudinal halfway point.

IMPORTANT The bench seat and the Crew Cab Van version 4-seater seat are not suitable for positioning a child restraint system.

## SETUP FOR "UNIVERSAL ISOFIX" CHILD RESTRAINT SYSTEM

The vehicle is set up for fitting an Isofix child restraint system.

The ISOFIX system lets you install the ISOFIX child restraining system quickly, simply and safely, without using the vehicle seat belts, but by connecting the child restraint system directly to the vehicle seat with three anchors in the vehicle. Traditional child restraint systems can be fitted alongside ISOFIX child restraint systems on different seats in the same vehicle.

To install an ISOFIX child restraint system, attach it to the two metal anchorings (A) fig. 189 located where the rear seat cushion meets the backrest, then fix the upper strap (available together with the restraint system) to the dedicated anchoring (B) fig. 190 located at the bottom behind the backrest.

fig. 192 shows an example of a Universal ISOFIX child restraint system for weight group 1.

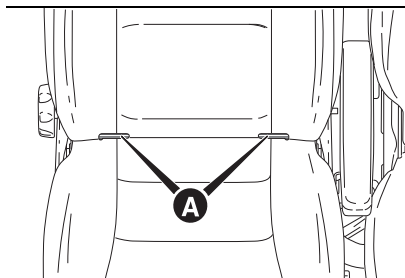

189

F1A0156

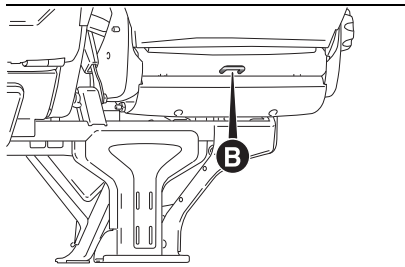

190

F1A0157

**NOTE** When a Universal ISOFIX child restraint system is used, only ECE R44 "ISOFIX Universal" (R44/03 or further upgrades) type-approved child restraint systems can be used fig. 191.

**WARNING** The fig. 192 is indicative and for assembly purposes only. Fit the child restraint system according to the instructions, which must be included.

⚠ 107 108 109 110

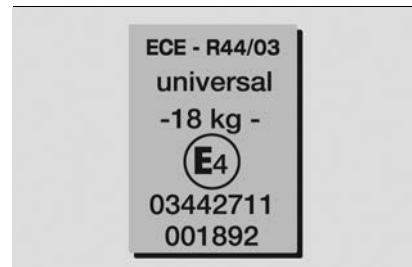

191

F1B0117C

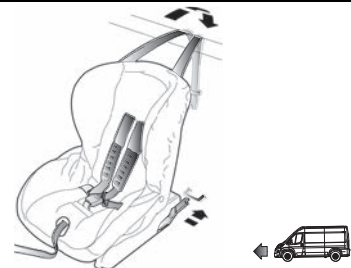

192

F1A0155



### IMPORTANT

**107)** Fit the child restraint system only when the vehicle is stationary. The child restraint system is correctly fixed to the brackets when you hear the click. Follow the instructions for assembly, disassembly and positioning that the Manufacturer must supply with the child restraint system.



**108)** Fiat Professional recommends fitting the child restraint system according to the instructions, which must be included.

**109)** Never use the same lower anchorage to attach more than one child restraint.

**110)** If a Universal ISOFIX child restraint system is not fixed to all three anchorages, it will not be able to protect the child correctly. In a crash, the child could be seriously or fatally injured.

## SUITABILITY OF PASSENGER SEATS FOR USE WITH ISOFIX CHILD SEATS

The table below shows the different installation possibilities for "Universal ISOFIX" child restraint systems on the seats fitted with ISOFIX attachments, in accordance with European regulation ECE 16.

| Weight group                 | Child restraint system position | Isofix size class | Rear side Isofix position, 1st row (PANORAMA) | Rear side Isofix position, 1st row (COMBI) |
|------------------------------|---------------------------------|-------------------|---|--|
| Portable cradle              | Rear facing                     | F                 | X   | X  |
|                              | Rear facing                     | G                 | X   | X  |
| Group 0 (up to 10 kg)        | Rear facing                     | E                 | IL  | IL   |
|                              | Rear facing                     | E                 | IL  | IL   |
| Group 0+ (up to 13 kg)       | Rear facing                     | D                 | IL  | IL   |
|                              | Rear facing                     | C                 | IL  | IL   |
|                              | Rear facing                     | D                 | IL  | IL   |
| Group 1 (from 9 up to 18 kg) | Rear facing                     | C                 | IL  | IL   |
|                              | Forward facing                  | B                 | IUF   | IUF  |
|                              | Forward facing                  | B1                | IUF   | IUF  |
|                              | Forward facing                  | A                 | IUF   | IUF  |
|                              | Forward facing                  | A                 | IUF   | IUF  |

X: ISOFIX position not suitable for ISOFIX child restraint systems in this weight group and/or size class.

IL: suitable for Isofix child restraint systems of the "Specific for the vehicle", "Restricted", or "Semiuniversal" categories, approved for this type of vehicle.

IUF: suitable for forward facing Isofix child restraint systems of the universal category, approved for use in the weight group.

**WARNING** The bench seat and the Crew Cab Van version 4-seater seat are not suitable for positioning a child restraint system.



NOTE: The other weight groups are covered by specific ISOFIX child restraint systems, which can only be used if specifically tested for this vehicle (see list of vehicles provided with the child restraint system).

## i-Size CHILD RESTRAINT SYSTEMS

These child restraint systems, built and type-approved according to the i-Size (ECE R129) standard, ensure better safety conditions to carry children on board a vehicle:

- ❑ the child must be transported rearward facing until 15 months;
- ❑ child restraint system protection is increased in the event of a side collision;
- ❑ the use of the ISOFIX system is promoted to avoid faulty installation of the child restraint system;
- ❑ efficiency in the choice of the child restraint system, which isn't made according to weight any more but according to the child's height, is increased;
- ❑ compatibility between the vehicle seats and the child restraint systems is better: the i-Size child restraint systems can be considered as "Super ISOFIX"; this means that they can be perfectly fitted in type-approved i-Size seats, but can also be fitted in ISOFIX (ECE R44) type-approved seats.

**WARNING** If your vehicle seats are i-Size approved, the fig. 193symbol will appear on the seats near the ISOFIX attachments.



193

J0A0450

**WARNING** See the table shown on the following page to check whether your vehicle is approved for installing i-Size child restraint systems.



The following table, according to European standard ECE 129, indicates the possibility of i-Size child restraint system installation.

|                                | i-Size POSITIONS ON THE VEHICLE |                 |                      |                        |
|--------------------------------|---------------------------------|-----------------|----------------------|------------------------|
|                                | Device                          | Front passenger | Rear side passengers | Rear central passenger |
| i-Size child restraint systems | ISO/R2                          | X               | X                    | X                      |
|                                | ISO/F2                          | X               | X                    | X                      |

X: seat not suitable for Universal i-Size child restraint systems.

**WARNING** This vehicle is not approved for use with i-Size child restraint systems. Despite this, it may be possible to install an "i-Size" child restraint system. Check compatibility of the vehicle with the child restraint system on the manufacturer's Internet website.



## CHILD RESTRAINT SYSTEMS RECOMMENDED BY FIAT PROFESSIONAL FOR YOUR NEW DUCATO

In the markets in which they are available, Lineaccessori MOPAR offers a complete range of child restraint systems to be fixed using the seat belt with three anchor points or the ISOFIX anchorages.

**WARNING** The manufacturer recommends fitting the child restraint system according to the instructions, which must be included with it

⚠ 111) 112) 113) 114)

| Weight group   | Child restraint system   | Type of child restraint system  | Child restraint system installation   |
|--|--|---|---|
| Group 0+: from birth to 13 kg<br>from 40 cm to 80 cm | <br>+  | <b>BeSafe iZi Go Modular</b><br>Fiat order code: 71808564<br><br><b>BeSafe iZi Modular i-Size Base</b><br>Fiat order code: 71808566 | Universal/i-Size child restraint system. It must be installed facing rearwards, using the vehicle seat belts only, or the dedicated i-Size base (which can be purchased separately) and the vehicle ISOFIX anchorages. It must be fitted on the rear outer seats. |



Weight group

Child restraint system

Type of child restraint system

Child restraint system installation

Group 0+/1: from 9 up to  
18 kg  
from 67 cm to 105 cm



+

+

**BeSafe iZi Modular i-Size**

Fiat order code: 71808565

**BeSafe iZi Modular i-Size Base**

Fiat order code: 71808566

The approved i-Size child restraint system that **must** be installed in the vehicle together with the underneath iZi Modular i-Size Base, which can be purchased separately. It can be installed facing forwards or facing backwards (refer to the child restraint system manual) It must be fitted on the rear outer seats.

Group 2: from 15 kg to 25  
kg  
from 95 cm to 135 cm

**Britax Römer KidFix XP**

It can only be fitted facing forwards, using the three-point seat belt and the ISOFIX anchorages, if present. **The Manufacturer will recommends installing it using the ISOFIX anchor points of the vehicle.** It must be fitted on the rear outer seats.

Group 3: from 22 kg to 36 kg  
from 136 cm to 150 cm

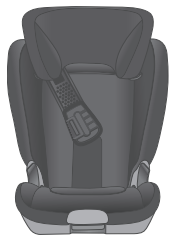

**Britax Römer KidFix XP**

It can only be fitted facing forwards, using the three-point seat belt and the ISOFIX anchorages, if present. **The Manufacturer will recommend installing it using the ISOFIX anchor points of the vehicle.** It must be fitted on the rear outer seats.



### IMPORTANT

**111)** Fit the child restraint system only when the vehicle is stationary. The child restraint system is correctly fixed to the brackets when you hear the click. Follow the instructions for assembly, disassembly and positioning that the Manufacturer must supply with the child restraint system.

**112)** Fiat Professional recommends fitting the child restraint system according to the instructions, which must be included.

**113)** Never use the same lower anchorage to attach more than one child restraint.

**114)** If a Universal ISOFIX child restraint system is not fixed to all three anchorages, it will not be able to protect the child correctly. In a crash, the child could be seriously or fatally injured.

## Below is a summary of the main safety rules to be followed when carrying children



- ❑ The recommended position for installing child restraint systems is on the rear seat, as it is the most protected area in the event of an impact.
- ❑ Keep children in rearward facing child restraint systems for as long as possible, until 3–4 years old if possible.
- ❑ If the passenger front airbag is deactivated, always check the corresponding LED on the button  on the instrument panel to make sure that it has actually been deactivated.
- ❑ Carefully follow the instructions that come with the child seat, which the manufacturer must supply. Keep the instructions in the vehicle along with the other papers and this handbook. Do not use second-hand child seats without instructions.
- ❑ Always check that the seat belt is well fastened by pulling on it.
- ❑ Only one child is to be strapped into each restraint system; never carry two children using one child restraint system.
- ❑ Always check that seat belts do not rest on the child's neck.

- ❑ While travelling, do not let the child sit incorrectly or unfasten the belts.
- ❑ Never carry children on your lap, even newborns. No-one can hold a child in the case of a collision.
- ❑ Never allow a child to put the belt's diagonal section under an arm or behind their back.
- ❑ If the vehicle has been involved in a road accident, replace the child restraint system with a new one. In addition, and depending on the type of child restraint system installed, replace the ISOFIX anchorages or the seat belt with which the child restraint system was connected.
- ❑ The rear headrest can be removed if needed to install a child restraint system. The head restraint must always be fitted in the vehicle if the seat is used by an adult passenger or a child sitting in a restraint system without backrest.



### IMPORTANT

**115)** Do not place a rear-facing cradle seat on the front seat if the passenger side airbag is enabled. Deployment of the airbag in an accident could cause fatal injuries to the child regardless of the severity of the impact. It is advisable to always carry children in a child restraint system on the rear seat, which is the most protected position in the event

of a collision. If you need to carry a child on the front passenger seat in a rear-facing cradle restraint system, the passenger side airbags (front and side bags for chest/pelvis protection, for versions/markets, where provided) must be deactivated using the setup menu. It is important to check the dedicated LED on button  on the dashboard to make sure that they are actually deactivated. Move the passenger's seat as far back as possible to avoid contact between the child seat and the dashboard.

## SUPPLEMENTARY RESTRAINT SYSTEM (SRS) - AIRBAG

The vehicle may be equipped with:

- ❑ front driver airbag;
- ❑ front passenger airbag;
- ❑ front side bags to protect the pelvis and chest of the driver and passenger;
- ❑ window bags to protect the heads of the front seat occupants.

The airbag locations on the vehicle are marked by the word "AIRBAG" in the middle of the steering wheel, on the dashboard, on the side lining or on a label placed next to the airbag deployment area.

### FRONT AIRBAGS

The front airbags protect the front seat occupants in the event of a medium-high severity frontal impact, by placing

the bag between the occupant and the steering wheel or dashboard.

Therefore, non-activation in other types of collisions (side collisions, rear shunts, roll-overs, etc.) is not a system malfunction.

An electronic control unit will make the bag inflate in the event of a frontal impact.

The bag will inflate instantaneously placing itself between the front occupants body and the structures which could cause injury. It will deflate immediately afterwards.

Front airbags are not a replacement of but complementary to the seat belts, which you are recommended to always wear, as specified by law in Europe and most non-European countries.

In the event of a collision, someone not wearing a seat belt could move forward and come into contact with a bag which is still opening. The protection offered by the bag is compromised in these circumstances.

Front airbags may not activate in the following situations:

- frontal impacts against highly deformable objects not involving the front surface of the vehicle (e.g. wing collision against guard rail, etc.);
- when the vehicle is wedged under other vehicles or protective barriers (e.g. under a lorry or a guardrail);

Failure to deploy in the conditions described above is due to the fact that the airbags may not provide any additional protection compared with seat belts, so their activation would be inappropriate. In these cases, non-deployment does not indicate a system malfunction.



The driver's and passenger's front airbags have been designed and calibrated to protect front seat occupants wearing seat belts. At their maximum inflation, their volume fills most of the space between the steering wheel and the driver and between the dashboard and the passenger.

The airbags are not deployed in the event of minor frontal impacts (for which the restraining action of the seat belts is sufficient).

Seat belts must always be worn. In the event of a frontal impact, they ensure the correct positioning of the occupant.

### **DRIVER'S SIDE FRONT AIRBAG**

This consists of an instant-inflating bag contained in a special compartment in the centre of the steering wheel fig. 194.

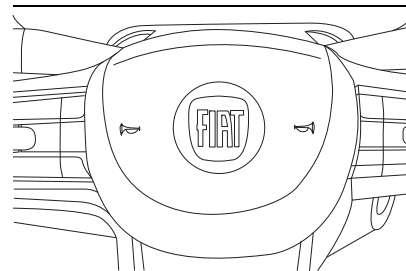

194

F1A0680

### **PASSENGER'S FRONT AIRBAG**

(for versions/markets, where provided)

This consists of an instantly inflating bag contained in a special compartment in the dashboard fig. 195: this bag has a larger volume than that on the driver side.

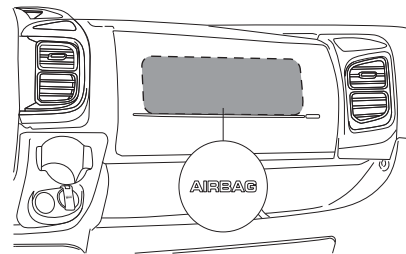

195

F1A0774



## PASSENGER'S FRONT AIRBAG AND CHILD RESTRAINT SYSTEMS

 117)

Rearward facing child restraint systems must **NEVER** be fitted on the front seat with an active passenger airbag since in the event of a collision the airbag activation may cause fatal injuries to the transported child.



196

F1A0773

**ALWAYS** comply with the instructions on the label stuck on the passenger side sun visor fig. 196.

### Manual deactivation of front passenger side airbag and side bag

(for versions/markets, where provided) If a child must necessarily be carried on the front seat in a rearward-facing child restraint system, the front passenger airbag and side bag (for

versions/markets, where provided) can be deactivated.

**WARNING** To manually deactivate the front passenger airbag and side bag (for versions/markets, where provided), refer to the "Display" chapter the "Knowing the instrument panel" section). The LED on the button switches on in case of deactivation.

The LED that corresponds to the symbol  fig. 197 on the dashboard indicates the passenger's protection status. If the LED is off, the passenger side protection is activated.

When the front passenger airbag and side bag (for versions/markets, where provided) are activated again, the warning light turns off.

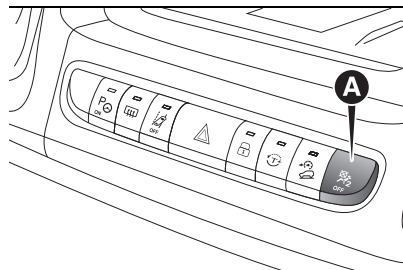

197

F1A0647

When the vehicle is started (key in MAR position), the LED turns on for

approx. 8 seconds, provided that at least 5 seconds have elapsed from the previous switching off. If not, contact a Fiat Dealership.

If the vehicle is switched off/on again in less than 5 seconds the LED may remain off. In this case, to check correct LED operation, switch the vehicle off, wait at least 5 seconds and switch on again.

During the first 8 seconds, the activation of the LED does not actually show the passenger protection status, but only checks its correct operation. The LED is tested also for markets where the passenger protection deactivation is not provided, and the LED switches on for less than one second when the key is turned to MAR, and then switches off again.

The warning light may light up with various intensity levels depending on the vehicle conditions. The intensity may also vary during the same key cycle.



### IMPORTANT

**116)** Do not apply stickers or other objects to the steering wheel, the dashboard in the passenger side airbag area and the seats. Never put objects (e.g. mobile phones) on the passenger side of the dashboard since they could interfere with correct inflation

of the passenger airbag and also cause serious injury to the passengers.

**117)** When there is an active passenger airbag, DO NOT install rearward facing child restraint systems on the front seat. Deployment of the airbag in a crash could cause fatal injuries to the child regardless of the severity of the collision. Therefore, always deactivate the passenger side airbag when a rearward facing child restraint system is installed on the front passenger seat. The front passenger seat must also be positioned back as far as possible in order to prevent the child restraint system from coming into contact with the dashboard. Immediately reactivate the passenger airbag as soon as the child restraint system has been removed.



## PASSENGER SIDE FRONT AIRBAG AND CHILD RESTRAINT SYSTEMS: IMPORTANT

|            |  |
|------------|--|
| <b>I</b>   | RISCHIO DI FERITE GRAVI O MORTALI. I seggiolini bambino che si montano nel verso opposto a quello di marcia non vanno installati sui sedili anteriori in presenza di air bag passeggero attivo.                                  |
| <b>GB</b>  | DEATH OR SERIOUS INJURY CAN OCCUR.<br>NEVER use a rearward facing child restraint on a seat protected by an ACTIVE AIRBAG in front of it, DEATH or SERIOUS INJURY to the CHILD can occur   |
| <b>F</b>   | RISQUE DE MORT OU DE BLESSURES GRAVES. NE PAS positionner le siège pour enfant tourné vers l'arrière, en cas d'air bag passager actif.   |
| <b>D</b>   | Nichtbeachtung kann TOD oder SCHWERE VERLETZUNGEN zur Folge haben.<br>Rückwärts gerichtete Kinderrückhaltesysteme (Babyschale) dürfen nicht in Verbindung mit aktiviertem Beifahrerairbag auf dem Beifahrersitz verwendet werden |
| <b>NL</b>  | DIT KAN DODELIJK ZIJN OF ERNSTIGE ONGELUKKEN VEROORZAKEN. Plaats het kindertoeltje niet ruggelings op de voorstoel wanneer er een airbag aanwezig is.  |
| <b>E</b>   | PUUDE OCACIONAR MUERTE O HERIDAS GRAVES. NO ubicar el asiento para niños en sentido inverso al de marcha en el asiento delantero si hubiese airbag activo lado pasajero.   |
| <b>PL</b>  | MOŻE GROZIĆ ŚMIERCIĄ LUB CIĘŻKIMI OBRAŻENIAMI.<br>NIE WOLNO umieszczać fotelika dziecięcego tyłem do kierunku jazdy na przednim siedzeniu w przypadku zainstalowanej aktywnej poduszki powietrznej pasażera.                     |
| <b>TR</b>  | ÖLÜM VEYA AĞIR ŞEKİLDE YARALANMAYA SEBEP OLABİLİR. Yolcu airbağı aktif halde iken çocuk koltuğunu araç gidis yönüne ters biçimde yerleştirmeyin.   |
| <b>DK</b>  | FARE FOR DØDELIGE KVÆSTELSER OG LIVSTRUENDE SKADER. Placer aldrig en bagudvendt barnstol på passageresædet, hvis passager-airbagen er indstillet til at være aktiv (on).   |
| <b>EST</b> | TAGAJÄRJEKS VÕIVAD OLLA TÕSISED KEHAVIGASTUSED VÕI SURM. Turvapadja olemasolu korral ärge asetage lapse turvaistet sõidusuunaga vastassuunas.  |
| <b>FIN</b> | KUOLEMANVAARA TAI VAKAVIEN VAMMOJEN UHKA. Älä aseta lasten turvaistuinta niin, että lapsi on selkää menossa, kun matkustajan airbag on käytössä.   |
| <b>P</b>   | RISCO DE MORTE OU FERIMENTOS GRAVES. Não posicionar o banco para crianças numa posição contrária ao sentido de marcha quando o airbag de passageiro estiver activo.  |
| <b>LT</b>  | GALI IŠTIKTI MIRTIS ARBA GALITE RIMTAI SUSIŽEISTI. Nedėkite vaiko sėdynės atgretos nugarą į priekinį automobilio stiklą ten, kur yra veikiant keleivio oro pagalvė.  |
| <b>S</b>   | KAN VARA LIVSHOTANDE ELLER LEDA TILL ALLVARLIGA SKADOR. Placera aldrig en bakåtvänd barnstol i framsätet då passagerarsidans krockkudde är aktiv.  |
| <b>H</b>   | HALÁSÓS VAGY SÚLYOS BALESET KÖVETKEZHET BE. Ne helyezzük a gyermekülést a menetirányal szembe, ha az utas oldalán légszák működik.   |
| <b>LV</b>  | VAR IZRAISĪT NĀVI VAI NOPIETNAS TRAUMAS. Nenovietot mazuļa sēdekli pretēji braukšanas virzienam, ja pasažiera pusē ir uzstādīts gaisa spilvens.  |
| <b>CZ</b>  | HROZÍ NEBEZPEČÍ VÁŽNĚHO UBLIŽENÍ NA ZDRAVÍ NEBO DOKONCE SMRTI. Neumísťujte detskou sedačku do opačnej polohy vŕči smeru jazdy v prípade aktívneho airbagu spolujazdce.   |
| <b>SLO</b> | LAHKO PRIDE DO SMRTI ALI HUDIH POŠKODB. Otroškega avtomobilskega sedeža ne nameščajte v obratni smeri vožnje, če ima vozilo vgrajene zračne blazine za potnike.  |
| <b>RO</b>  | SE POATE PRODUCÉ DECESUL SAU LEZIUNI GRAVE. Nu aşezaţi scaunul de maşină pentru bebeluşi în poziţie contrară direcţiei de mers atunci când airbag-ul pasagerului este activat.   |
| <b>GR</b>  | ΜΠΟΡΕΙ ΝΑ ΠΡΟΚΛΗΘΟΥΝ ΘΑΝΑΤΟΣ Ή ΣΟΒΑΡΑ ΤΡΑΥΜΑΤΑ.<br>Μην τοποθετείτε το καρεκλάκι αυτοκινήτου για παιδιά σε αντίθετη προς την φορά πορείας θέση σε περίπτωση που υπάρχει αερόσακος εν ενεργεία στη θέση συνεπιβάτη.                |
| <b>BG</b>  | ИМА ОПАСНОСТ ОТ СМЪРТ И СЕРИОЗНИ НАРАНЯВАНИЯ.<br>Не поставяйте столчето за пренасяне на бебета в положение обратно на посоката на движение, при положение активно на въздушната възглавница за пътуване.                         |
| <b>SK</b>  | MŮŽE NASTAŤ SMŤ ALEBO VÁŽNE ZRANENIA. Nedávajte autosedačku pre deti do polohy proti chodu vozidla, keď je aktívny airbag spolujazdca.   |
| <b>RUS</b> | ТРАВМЫ И ЛЕТАЛЬНЫЙ ИСХОД. Детское кресло, устанавливающееся против направления движения, нельзя монтировать на месте переднего пассажира, если последнее оборудовано активной подушкой безопасности.                             |
| <b>HR</b>  | OPASNOST OD TEŠKIH ILI SMRTNOSNIH OZLJEDA.<br>Sjedala za djecu koja se montiraju u smjeru suprotnom od vožnje ne smiju se instalirati na prednja sjedala ako postoji aktivni zračni jastuk suvozača.                             |
| <b>AS</b>  | قد تحدث حالات وفاة أو إصابات بالغة. لا تستخدم مقاعد الأمان الخاصة بالأطفال على مقعد مزود "بوسادة هوائية"، حيث إن الطفل قد يتعرض للوفاة أو لإصابة بالغة.  |

198

F1A0387



## SIDE BAGS

 118) 119) 120) 121) 122) 123) 124) 125) 126) 127) 128) 129) 130) 131)

To help increase occupant protection in the event of a side collision, for versions/markets where provided, the vehicle is equipped with front side bags and window bags.

Side bags (for versions/markets, where provided) protect occupants from side impacts of medium-high severity, by placing the bag between the occupant and the internal parts of the side structure of the vehicle. Non-activation of side bags in other types of collisions (front collisions, rear shunts, roll-overs, etc.) is not a system malfunction. An electronic control unit causes the bags to inflate in the event of a side collision. The bags inflate instantaneously, placing themselves between the occupant's body and the structures which could cause injury. They deflate immediately afterwards. Side bags (for versions/markets, where provided) are not a replacement of but complementary to the belts, which you are recommended to always wear, as specified by law in Europe and most non-European countries.

## FRONT SIDE BAGS FOR CHEST PROTECTION

(for versions/markets, where provided) Housed in the seat backrests fig. 199, they are composed of an instantly inflating bag, which serves to protect the occupants' chest and pelvis in the event of a medium-high severity side collision.



199

F1A0180

## WINDOW BAGS

(for versions/markets, where provided) They consist of two curtain bags, one on the right and the other on the left side of the vehicle, located behind the side coverings of the roof and covered by special finishing fig. 200.

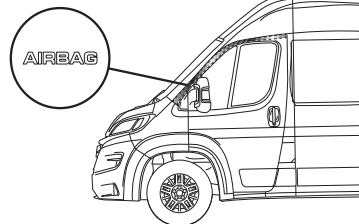

200

F1A0333

Window bags have been designed for protecting the head of front occupants in the event of side collision, thanks to the wide bag inflation surface.

**WARNING** In the event of a side collision, the system offers best protection if you keep a correct position on the seat because this allows the side bags to inflate correctly.

**WARNING** The front airbags and/or side bags may be deployed if the vehicle is subject to heavy knocks or accidents involving the underbody area, such as for example violent shocks, against steps, kerbs or low obstacles, vehicle falling into big potholes or depressions in the road.

**WARNING** A small amount of dust will be released when the airbags are



deployed. The dust is not harmful and does not indicate the beginning of a fire. Furthermore, the surface of the deployed bag and the interior of the vehicle may be covered in a dusty residue: this may irritate your skin and eyes. Wash with mild soap and water in the event of exposure.

**WARNING** Should an accident occur in which any of the safety devices are activated, take the vehicle to a Fiat Dealership to have the activated devices replaced and to have the whole system checked.

Every control, repair and replacement operation concerning the airbags must be carried out only at Fiat Dealerships. If you are having the vehicle scrapped, have the system deactivated at a Fiat Dealership first. If the vehicle changes ownership, the new owner must be informed of how to use the airbags and the above warnings and also be given this "Owner Handbook".

**WARNING** Pretensioners, front airbags and front side bags are deployed differently according to the type of collision. Failure to activate one or more of the devices does not indicate a system malfunction.



## IMPORTANT

**118)** *Never rest head, arms and elbows on the doors, on the windows and in the window bag head protection area to prevent possible injuries during inflation phase.*

**119)** *Never lean your head, arms or elbows out of the window.*

**120)** *If when turning the key to MAR the warning light  does not turn on or stays on whilst driving, a failure may have occurred in the restraint systems. In this case the airbags or pretensioners may not be deployed in an impact or, in a lower number of cases, they may be deployed accidentally. Contact a Fiat Dealership immediately to have the system checked.*

**121)** *Do not cover the backrest of the front or rear seats with covers which are not suitable for use with side bags.*

**122)** *Do not travel with objects in your lap, in front of your chest or held in your mouth (e.g., pipe, pencil etc.). They could cause severe injury if the airbag is deployed in a crash.*

**123)** *The airbag must be able to inflate without obstruction in the event of deployment. It is therefore recommended not to drive with the body bent forward, but to sit up resting your back and shoulders on the backrest of the seat. Adjusting the position of the seat so that you can reach and manoeuvre the steering wheel comfortably with your arms slightly bent being as far away as possible from the steering wheel. Being too close to the steering wheel when the airbag is deployed may cause serious injury.*

**124)** *The airbags may also be deployed when the vehicle is not moving, if the ignition key is inserted and turned to MAR even when the engine is off, if the vehicle is hit by another moving vehicle. Therefore, even if the vehicle is stationary, when an active front passenger airbag is fitted, DO NOT install rear facing child restraint systems on the front passenger seat. Deployment of the airbag following an impact could cause fatal injuries to the child. Therefore, always deactivate the passenger side airbag when a rearward facing child restraint system is installed on the front passenger seat. The front passenger seat must also be positioned back as far as possible in order to prevent the child restraint system from coming into contact with the dashboard. Immediately reactivate the passenger airbag as soon as the child restraint system has been removed. Also remember that, if the key is turned to STOP, none of the safety devices (airbags or pretensioners) will be deployed in the event of collision. Non-deployment in such cases does not indicate a system malfunction.*

**125)** *Have the airbag system checked by a Fiat Dealership if the vehicle was stolen, if theft was attempted, or if the vehicle was subjected to vandalism or flooding.*





**126)** *By turning the ignition key to MAR position, the LED on the  button located on the dashboard lights up (the time it stays lit up can vary depending on the market), to check that the button LED is working correctly.*

**127)** *Do not wash the seats with water or pressurised steam (wash by hand or at automatic seat washing stations).*

**128)** The front airbag deployment threshold is higher than that of the pretensioners. For impacts whose intensity falls between the two levels, normally, only the pretensioners will be activated.

**129)** Do not affix rigid objects to the coat hooks or support handles.

**130)** The airbag does not replace seat belts but increases their efficiency. Furthermore, since front airbags are not deployed in low-speed frontal impacts, side impacts, rear shunts or roll-overs, the passengers are protected only by the seat belts which must therefore be fastened at all times.

**131)** In some versions, in case of LED failure  **OFF** (located on the plate of the instrument panel), the light on the console turns on  and the passenger side airbags are deactivated. On some versions, in case of failure of the  **ON** LED (located on the dashboard), warning light  appears on the instrument panel.



# STARTING AND DRIVING

*Let's get to the core of the vehicle:  
seeing how you can exploit all of its  
potential to the full.*

*We'll look at how to drive it safely in any  
situation, so that it can be a welcome  
companion, with our comfort and our  
wallets in mind.*

|  |     |   |     |
|--|-----|---|-----|
| STARTING THE ENGINE .....  | 159 | SAVING FUEL.....  | 208 |
| WHEN PARKED.....   | 160 | REFUELLING THE VEHICLE .....                                      | 210 |
| ELECTRIC PARKING BRAKE<br>(EPB).....   | 162 | ADBLUE <sup>®</sup> (UREA) ADDITIVE<br>FOR DIESEL EMISSIONS ..... | 213 |
| MANUAL TRANSMISSION .....  | 165 | LOADING ADVICE.....   | 213 |
| AUTOMATIC TRANSMISSION .....   | 165 | TOWING TRAILERS.....  | 214 |
| "DRIVE MODE" FUNCTION.....   | 170 | PROLONGED VEHICLE<br>INACTIVITY .....                             | 220 |
| START&STOP SYSTEM .....  | 171 | BATTERY DISCONNECTION<br>FUNCTION (DISCONNECTOR).....             | 220 |
| ECO FUNCTION .....   | 174 |   |     |
| SPEED LIMITER.....   | 174 |   |     |
| ELECTRONIC CRUISE<br>CONTROL .....   | 175 |   |     |
| ENGINE IDLE PRESET .....   | 177 |   |     |
| SPEED BLOCK.....   | 178 |   |     |
| PARKSENSE SYSTEM.....  | 178 |   |     |
| AUTOMATIC PARK ASSIST -<br>ACTIVE PARKSENSE SYSTEM ....                          | 182 |   |     |
| REAR CAMERA (ParkView <sup>®</sup><br>Rear Backup Camera).....                   | 187 |   |     |
| TRAFFIC SIGN RECOGNITION.....  | 188 |   |     |
| INTELLIGENT SPEED ASSIST.....  | 190 |   |     |
| ADAPTIVE CRUISE CONTROL<br>(ACC) .....   | 191 |   |     |
| CO-DRIVER SYSTEM WITH<br>STOP&GO - Adaptive Cruise<br>Control with Stop&Go ..... | 198 |   |     |
| CO-DRIVER SYSTEM WITH<br>STOP&GO - Traffic Jam Assist .....                      | 205 |   |     |

## STARTING THE ENGINE



The vehicle is fitted with an electronic motor lock device: if the motor fails to start, see the "Fiat CODE system" chapter in the "Knowing your vehicle" section .

Before starting the vehicle, adjust the seat, the interior rear view mirrors, the door mirrors and fasten the seat belts correctly. Never press the accelerator pedal for starting the engine.

**WARNING** If the accelerator pedal and the brake pedal are accidentally pressed at the same time, the system will consider the braking request has having a higher priority. In this condition, the engine will switch to recovery mode and performance (engine torque and vehicle speed) will be limited. To restore normal operation, simply release the accelerator pedal. It is not necessary to stop and start the engine.



## PROCEDURE FOR VERSIONS WITH MANUAL TRANSMISSION

Proceed as follows:

- engage the parking brake;
- put the gear lever into neutral;
- take the ignition device to **MAR**: the warning lights and on the instrument panel will turn on;
- wait for the warning lights and to switch off. The hotter the engine is, the quicker this will happen;
- fully depress the clutch pedal without touching the accelerator;
- take the ignition device to AVV as soon as warning light switches off. Waiting too long will waste the heating work carried out by the plugs. Release the key as soon as the engine starts.

## PROCEDURE FOR VERSIONS WITH AUTOMATIC TRANSMISSION

Starting the engine is allowed only when the gear lever is in position P or N, so when the engine is started, the system is at position N or P (the latter means neutral, but the vehicle wheels are locked mechanically).



## VEHICLE MOVEMENT

To move the vehicle, from position P press the brake pedal and move the gear lever to the desired position (D or "Sequential mode") to move forward or R to engage reverse).

The gear engaged will be shown on the instrument panel display. When the brake pedal is released, the vehicle starts moving forwards or backwards, as soon as the manoeuvre is activated ("creeping" effect). It is not necessary to press the accelerator pedal in this case.

**WARNING** The inconsistency between the speed actually engaged (shown on the instrument panel display) and the position of the gear lever is indicated by the letter corresponding to the position of the lever flashing on the trim (also accompanied by an acoustic signal). This condition should not be interpreted as an operational fault, but simply as a request by the system to repeat the manoeuvre.

**WARNING** With the parking brake released and brake pedal released, engine at idling speed and gear lever in position D, R or sequential, pay the utmost care because the vehicle can move even without the operation of the accelerator pedal. This condition



can be used with the vehicle on a level surface during tight parking manoeuvres using the brake pedal only.



39)

### WARMING UP THE ENGINE JUST AFTER IT HAS STARTED

Proceed as follows:

- drive off slowly, letting the engine turn at medium revs. Do not accelerate abruptly;
- do not demand full performance at first. Wait until the engine coolant temperature gauge starts moving.



40) 41)

### ENGINE STARTING FAILURE

#### Starting the engine with electronic key battery (Keyless Enter-N-Go) run down or flat

If the ignition device does not respond when the relevant button is pressed the electronic key battery might be run down or flat. Therefore, the system does not detect the presence of the electronic key on board the vehicle and displays a dedicated message. In this case, rest the rounded edge of the electronic key (the side opposite the metal insert) on the ignition device and press the button using the

electronic key. The ignition device is thus activated and the engine can be started.

### SWITCHING OFF THE ENGINE

Turn the ignition device to STOP with the engine idling.



#### IMPORTANT

**132)** *It is dangerous to run the engine in enclosed areas. The engine consumes oxygen and engine exhaust contains carbon dioxide, carbon monoxide and other toxic gasses.*



#### WARNING

**35)** *A quick burst on the accelerator before stopping the engine serves no practical purpose; it wastes fuel and is especially damaging to turbocharged engines.*

**36)** *It is advisable not to demand maximum performance from your vehicle (e.g. excessive acceleration, long distances at high speeds, excessive intense braking, etc.) during the initial period of use.*

**37)** *When the engine is switched off never leave the ignition device in the MAR position to prevent useless current absorption from draining the battery.*

**38)** *In some cases, when the engine switches off, the fan could activate for max. 120 seconds.*

**39)** *If the engine fails to start with a gear engaged, the potentially dangerous situation due to the fact that the transmission is automatically placed in neutral will be signalled by a buzzer.*

**40)** *Remember that the brake servo and power steering are not operational until the engine has been started, so you need to apply much more force than usual to the brake pedal and steering wheel.*

**41)** *Never bump start the engine by pushing, towing or coasting downhill. This could cause fuel to flow into the catalytic converter and damage it beyond repair.*

### WHEN PARKED



133)



42)

Proceed as follows when parking and leaving the vehicle:

- engage a gear (1<sup>st</sup> gear if facing uphill or reverse if facing downhill) and leave the wheels turned;
  - stop the engine and engage the parking brake;
  - always remove the ignition device.
- If the vehicle is parked on a steep slope, it is advisable to block the wheels with a wedge or stone.

WARNING NEVER leave the vehicle with the gearbox in neutral or, on versions equipped with automatic transmission, before placing the gear lever at P).

## VERSIONS WITH MANUAL TRANSMISSION

Proceed as follows:

❑ engage a gear (first gear if parked uphill or reverse if facing downhill) and leave the wheels turned.

❑ stop the engine and engage the parking brake;

If the vehicle is parked on a steep slope, it is advisable to block the wheels with a wedge or stone.

Do not leave the key in the ignition as this drains the battery. Always remove the key when you leave the vehicle.

## VERSIONS WITH AUTOMATIC TRANSMISSION

On versions with automatic transmission, keep the brake pedal pressed, apply the parking brake and engage the gear lever in position (P), wait for the letter P to appear on the display, after which the brake pedal can be released.

## GENERAL WARNINGS

❑ With the vehicle stationary and a gear engaged, always keep the brake pedal pressed until you decide to set off, then release the brake and accelerate gently;

❑ during prolonged stops with the engine running, it is advisable to keep the gearbox in neutral (N);

❑ to keep the clutch in good condition, do not use the accelerator to keep the vehicle stationary (e.g. when stopped facing uphill); the clutch could be damaged by overheating. Use the brake pedal instead and operate the accelerator only when you are ready to set off;

❑ only use second gear when you need greater control for starting manoeuvres on surfaces with poor grip;

❑ if, with reverse gear (R) engaged, you have to engage first gear or vice versa, only do this when the vehicle is completely stationary and with the brake pedal pressed;

❑ although it is strongly inadvisable, if you are driving downhill and, for unexpected reasons, you let the vehicle move forward with the transmission in neutral (N), when you engage a gear, the system will automatically engage the best gear to transmit the correct drive torque to the wheels depending on the vehicle speed;

❑ when necessary, you can engage 1<sup>st</sup>, (R) or (N) with the engine off, the key in the MAR position and the brake pressed. In this case, gear shifts must be made allowing at least 5 minutes to elapse between one gear shift and the next to safeguard the operation of the hydraulic system and the pump in particular;

❑ for hill starts, accelerating gradually but fully straight after having released the parking brake or the brake pedal allows the engine to greatly increase the revolutions per minute and tackle steeper slopes with more torque at the wheels.

❑ uphill on gradients steeper than 5% it is not allowed to engage the 2<sup>nd</sup> gear with vehicle stationary.

## PARKING BRAKE

**To apply the parking brake:** the parking brake lever is located on the left side of the driver's seat fig. 201. Pull the lever upwards to engage the parking brake and ensure that the vehicle does not move.

**WARNING** Make sure that the parking brake is engaged in such a way as to ensure the stationing of the vehicle, especially in the case of steep slopes and full load.

**WARNING** If this is not the case, contact a Fiat Dealership to have the handbrake adjusted. If the lever travel gets longer, contact a Fiat Dealership.

When the parking brake is engaged and the ignition key is at MAR, the  instrument panel warning light will turn on.



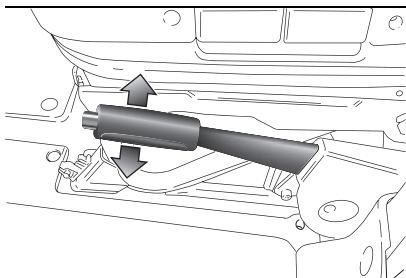

201

F1A0162

### To release the parking brake:

slightly raise lever and hold button (A) pressed, checking that the (P) warning light switches off in the instrument panel.

Press the brake pedal when carrying out this operation to prevent the vehicle from moving accidentally.

**WARNING** Apply the parking brake only when the vehicle is at a standstill or with the vehicle in motion only in the event of a failure in the hydraulic system. If exceptional use is made of the parking brake with the moving vehicle, moderate traction is advisable in order not to cause locking of the rear end with consequent swerving of the vehicle.



### IMPORTANT

**133)** Never leave children unattended in the vehicle. Always remove the ignition key when leaving the vehicle and take it out with you.



### WARNING

**42)** If the vehicle is equipped with self-levelling air suspension, always check that there is sufficient space above the roof and around the vehicle when parking. Indeed, the vehicle could raise (or lower) automatically depending on load or temperature changes.

## ELECTRIC PARKING BRAKE (EPB)

(where provided)

The vehicle is equipped with electric parking brake (EPB) to guarantee better use and optimal performance compared to a manually operated parking brake.

The electric parking brake features a switch, located on the lower part of the dashboard on driver side fig. 202, a motor with calliper for each rear wheel and an electronic control module.

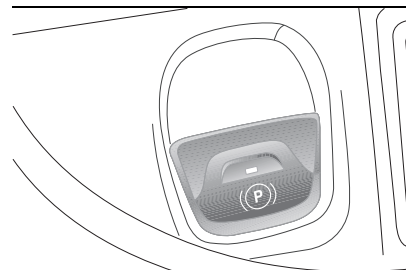

202

F1A0649

**WARNING** Always engage the electric parking brake before leaving the vehicle.

**WARNING** In addition to always parking the vehicle with the parking brake engaged, the steering wheel turned, chocks or stones positioned in front of the wheels (when on a steep slope), always engage a gear (1st gear with the car parked facing uphill or reverse gear with the vehicle parked facing downhill). On versions with automatic transmission/dual clutch automatic transmission, put the gear lever at P (Park).

**WARNING** Should the vehicle battery be faulty, to unlock the electric parking brake the battery must be replaced.



The electric parking brake can be engaged in two ways:

- *manually* by pulling the switch fig. 202 on the lower part of the dashboard on driver's side;
- *automatically* in "Safe Hold" or "Auto Park Brake" conditions.

### Engaging the parking brake manually

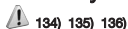

Briefly pull the switch located on the lower part of the dashboard on driver side to manually engage the electric parking brake when the vehicle is stationary.

Noise may be heard from the rear of the vehicle when engaging the electric parking brake.

A slight movement of the brake pedal may be detected when engaging the electric parking brake with the brake pedal pressed.

**WARNING** With the EPB failure warning light on, some functions of the electric parking brake are deactivated. In this case, the driver is responsible for brake activation and parking the vehicle in complete safety conditions.

If, under exceptional circumstances, the use of the brake is required with vehicle in motion, keep the switch on the lower part of the dashboard on

driver's side pulled as long as the brake action is necessary.

The warning light (ⓘ) may switch on with the hydraulic system temporarily unavailable; in this case braking is controlled by the motors.

The brake lights (stop) will also automatically switch on in the same way as for normal braking with the use of the brake pedal.

To stop the brake application while the vehicle is moving, release the switch on the lower part of the dashboard on driver's side.

If, through this procedure, the vehicle is braked until a speed below approx. 3 km/h (1.9 mph) is reached and the switch is kept pulled, the parking brake will definitively engage.

**WARNING** Driving the vehicle with the electric parking brake engaged, or using it several times to slow down the vehicle, may cause severe damage to the braking system.

### Disengaging the electric parking brake manually

The ignition device must be in the MAR position in order to manually release the parking brake. Furthermore, you need to press the brake pedal, then

press the switch on the lower part of the dashboard on driver's side.

Noise may be heard from the rear of the vehicle and a slight movement of the brake pedal may be detected during disengagement.

Each automatic parking brake engagement can be cancelled by pressing the switch on the lower part of the dashboard on driver side and at the same time moving the automatic transmission/dual clutch automatic transmission lever to position P (Park) or the ignition device to STOP (versions with manual transmission).

**WARNING** On versions with automatic transmission/dual clutch automatic transmission never use the P (Park) position instead of the electric parking brake. Always engage the electric parking brake when parking the vehicle to prevent injury or damage caused by the unexpected movement of the vehicle.

**WARNING** For versions with manual transmission, if the clutch pedal is pressed all the way and then released simultaneously with the press of the accelerator, the electric parking brake automatically releases.



## ELECTRIC PARKING BRAKE OPERATING MODES

The electric parking brake may operate as follows:

- ❑ “*Dynamic operating mode*”: this mode is enabled by pulling the switch continuously whilst driving;
- ❑ “*Static engagement and release mode*”: with the vehicle stationary, the electric parking brake can be activated by pulling the switch on the lower part of the dashboard on driver side. On the other hand, press the switch and the brake pedal at the same time to disengage the brake;
- ❑ “*Drive Away Release*” (where provided): the electric parking brake will automatically disengage with the detection of the driver’s intention to move vehicle forward or in reverse;
- ❑ “*Safe Hold*”: if the vehicle speed is lower than 3 km/h and, for the versions with automatic transmission/dual clutch automatic transmission, the gear lever is not in P (Park) position, and the driver’s intention to leave the vehicle is detected, the electric parking brake will automatically engage to hold the vehicle in safety conditions;
- ❑ “*Auto Park Brake*”: if the speed of the vehicle is lower than 3 km/h, the electric parking brake will automatically engage when the gear lever is moved

to P (Park) position (versions with automatic transmission/dual clutch automatic transmission), or with the ignition device at STOP (versions with manual transmission). The LED on the switch located in the lower part of the dashboard on driver side switches on together with the warning light (ⓘ) on the instrument panel when the parking brake is engaged and applied to the wheels.

### SAFE HOLD

It is a safety function that automatically engages the electric parking brake in the event of a dangerous condition for vehicle.

If:

- ❑ the vehicle speed is lower than 3 km/h;
  - ❑ the gear lever is not at P (Park) (versions with automatic transmission/dual clutch automatic transmission);
  - ❑ the driver leaves the driving seat;
  - ❑ no attempted operation of the brake pedal or the accelerator pedal or, on versions with manual transmission, the clutch pedal is detected;
- the electric parking brake engages automatically to prevent vehicle movement.

The Safe Hold function can be temporarily disabled by pressing the switch located on the lower part of the

dashboard on driver's side and the brake pedal at the same time, with the vehicle stationary and the driver side door open.

Once disabled, the function will activate again when the vehicle speed reaches 20 km/h or the ignition device is moved to STOP and then to MAR.



### IMPORTANT

**134)** *In the case of parking manoeuvres on roads on a gradient, the front wheels must be steered towards the pavement (when parking downhill), or in the opposite direction if the vehicle is parked uphill. If the vehicle is parked on a steep slope, it is advisable to block the wheels with a wedge or stone.*

**135)** *Never leave children unattended in the vehicle. In addition, always remove the ignition key when leaving the vehicle and take it out with you.*

**136)** *The electric parking brake must always be engaged when leaving the vehicle.*

## MANUAL TRANSMISSION

To engage the gears, press the clutch pedal fully and put the gear lever into the required position (the diagram for gear engagement is shown on the lever knob (A) fig. 203).

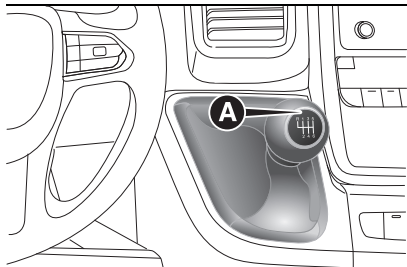

203

F1A0696

To engage 6<sup>th</sup> gear (where provided), operate the lever by pressing it towards the right in order to avoid engaging 4<sup>th</sup> gear by mistake. The same applies to the shift from 6<sup>th</sup> to 5<sup>th</sup> gear.

**WARNING** Reverse may only be engaged when the vehicle is at a standstill. With the engine running, wait for at least 2 seconds with the clutch pedal fully pressed before engaging reverse to prevent damage to the gears and grating.

**WARNING** The clutch pedal should be used only for gear changes.

Do not drive with your foot resting on the of the clutch pedal, however lightly. In some circumstances, the electronic of the clutch control could cut in by interpreting the incorrect driving style as a fault.

 137

 43) 44)



### IMPORTANT

**137)** Press the clutch pedal fully to shift gears correctly. It is therefore essential that there is nothing under the pedals: make sure the mats are lying flat and do not get in the way of the pedals.



### WARNING

**43)** Only rest your hand on the transmission when shifting gears. Do not drive with your hand resting on the gear knob (even only for a few seconds) as the force exerted, even if slight, could lead over time to premature wear of the gearbox internal components and impair its operation.

**44)** Do not place objects (e.g. bracelets, bags and/or purses) near the gear lever.

## AUTOMATIC TRANSMISSION

(for versions/markets, where provided)

Some versions are equipped with an electronically managed 9-speed automatic transmission with gears shifted automatically depending on the vehicle usage instantaneous parameters (vehicle speed, road gradient and accelerator pedal position).

The new transmission is an absolute innovation as it can match the Start&Stop system with the traditional automatic transmissions with built-in torque converter.

Manual shifting is still possible in "sequential mode".

### DISPLAY

#### Versions with 3.5" multifunction display

The following indications (A) fig. 204 appear on the display:

- in automatic mode: the selected gear (P, R, N, D1, D2, D3, D4, D5, D6);
- in sequential mode: gear engagement, with numeric indication.



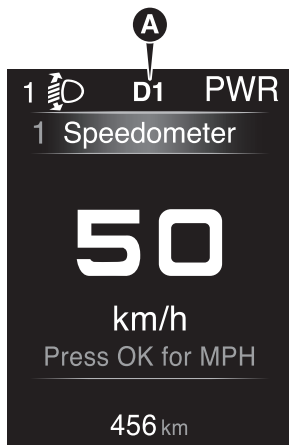

204

F1A0692

### Versions with 7" multifunction display

The following indications fig. 205 appear on the display:

- in sequential mode:** gear engagement, through the numerical indication (A) fig. 205.
- in automatic mode:** the selected gear (P, R, N, D1, D2, D3, D4, D5, D6) (B) fig. 205;



205

F1A0697

### GEAR LEVER

138) 139) 140) 141) 142) 143) 45)

The (A) fig. 206 lever has the following positions:

- P** = Park
- R** = Reverse
- N** = Neutral
- D** = Drive, (automatic forward speed)
- AutoStick:** + shifting to higher gear in sequential driving mode; – shifting to lower gear in sequential driving mode.

To select the "sequential" mode, shift the gear lever from D (Drive) towards the left. The reachable positions are + (higher gear) or - (lower gear). These positions are unstable: the gear lever always returns to central position.

The gear lever has a button which must be pressed to move the lever to P or R.

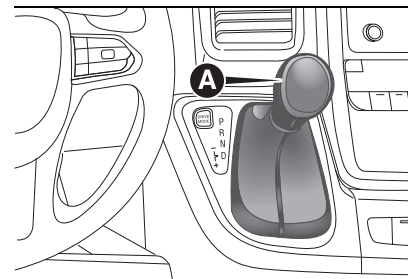

206

F1A0665

### LEVER POSITIONS

#### Park (P)

46)

The transmission is mechanically locked in position P.

The ignition key can be removed only when the lever is in position P.

The lever must only be moved from P to D when the vehicle is stationary and the engine at idling speed.

With the ignition key in the MAR position, press the brake pedal and use the button located on the gear lever to shift the selector lever from P to any other position.

#### WARNINGS

- Never try to select position P when the vehicle is moving.
- Before leaving vehicle, apply the electric parking brake and set the gear lever to this position.

❑ Before moving the gear lever to position P, apply the parking brake, otherwise moving the gear lever to P might be difficult.

❑ When restarting after a stop, the gear lever must be moved to position P before releasing the electric parking brake.

To check actual engagement of position P:

- ❑ move the gear lever completely forwards, to end of travel position;
- ❑ make sure that letter P is displayed on the instrument panel;
- ❑ with brake pedal released, make sure that the gear lever does not move from position P.

## Reverse (R)



The engine cannot be started with the lever in position R.

Shifting from R to N or D is free, while shifting from R to P can be made by the button on the gear lever, with engine at idling speed.

## Neutral (N)

It corresponds to neutral for a standard manual transmission. The engine can be started with the lever in position N. Engage N (or P) in case of prolonged stops.

After the lever has been in N for a couple of seconds, the brake pedal

must be pressed to move from the N to D or R position. It is advisable not to accelerate and to make sure that the engine is stabilised at idle speed.

## Drive (D) - Automatic forward gear

It is the lever position in standard running conditions.

You can shift from D to N freely, while you can only shift from D to R or P by pressing the button on the gear lever.

**WARNING** With the engine off and the ignition device in the MAR position, when the gear lever is positioned in R or D starting from N, the gear is not engaged.

## Sequential mode (+ / -)

Shifting the lever from position D on side in stable position, the transmission is used in sequential mode.

Shifting the lever to unstable position (+ or -) changes the gears.

**WARNING** All movements of the gear lever must be performed with the vehicle stationary and engine idling only.

## AUTOMATIC DRIVING MODE

To select the automatic driving mode, you need to shift the gear lever to

D. The best ratio is selected by the control unit depending speed, engine load (accelerator pedal position) and gradient of the road.

D can be selected from sequential operation in any driving conditions.

## Kick-Down function

To resume speed quickly, when the accelerator pedal is pressed fully, the transmission control system downshifts (kick-down function).

**WARNING** When driving on roads with poor grip conditions (snow, ice, etc.) avoid activating the kick-down function.

## Gearshifting suggestion

With the transmission in automatic mode (selector lever in position D), when gearshifting is required by the paddles on the steering wheel (where provided), the system shifts to "Sequential mode" ("Autostick"), displaying the engaged gear for about 5 seconds. When this time has elapsed, if the paddles are not operated anymore, the system goes back to the automatic mode (D), with following displaying.

## SEQUENTIAL DRIVING MODE - AUTOSTICK

In the case of frequent gear shifting (e.g. when the vehicle is driven with a



heavy load, on slopes, with strong headwind or when towing heavy trailers), it is recommended to use the Autostick (sequential shifting) mode to select and keep a lower fixed ratio.

In these conditions, using a lower gear improves vehicle performance and prolongs the life of the transmission, limiting gear shifting and preventing overheating. It is possible to shift from position D to the sequential mode regardless of vehicle speed.

### Activation

With gear lever in position D, to activate the sequential drive mode, move the lever to the left (indication – and + on the panel). The gear engaged will be shown on the display.

Tip the gear stick forwards, towards symbol – or backwards, towards symbol +, to shift gears.

### Deactivation

To deactivate the sequential driving mode, bring the gear lever back to position D (Drive).

## ENGINE STARTING

Starting the engine is allowed only when the gear lever is in position P or N. So when the engine is started, the system is at position N or P (the latter means neutral, but the vehicle wheels are locked mechanically).

## VEHICLE MOVEMENT

To move the vehicle, from position P press the brake pedal and move the lever to the desired position (D or "Sequential mode" move forward or R to engage reverse). The display will show the gear engaged. When the brake pedal is released, the vehicle starts moving forwards or backwards, as soon as the manoeuvre is activated ("creeping" effect). The accelerator should not be pressed in this case.

**WARNING** The inconsistency between the speed actually engaged (shown on the display) and the position of the gear lever is indicated by the letter corresponding to the position of the lever flashing on the trim (also accompanied by an acoustic signal). This condition should not be interpreted as an operational fault, but simply as a request by the system to repeat the manoeuvre.

**WARNING** With the parking brake released and brake pedal released, engine at idling speed and gear lever in position D, R or sequential, pay the utmost care because the vehicle can move even without the operation of the accelerator pedal. This condition can be used with the vehicle on a level surface during tight parking

manoeuvres using the brake pedal only.

## LEVER MOVEMENT INHIBITION

This system prevents you from moving the gear lever from position P if the brake pedal has not been previously pressed.

To bring the gear lever to a position other than P or from N to R, the ignition device must be in position MAR (engine on or off) and the brake pedal must be pressed.

In this case of faults or a discharged battery, the gear lever remains blocked in P. T manually release the lever, see the "Automatic transmission lever release" chapter in the "In case of emergency" section.

With the ignition device in MAR, if the lever remains in position N for more than about 2 seconds, it will be necessary to press the brake to be able to engage the gear (R and D). A message on the instrument panel will remind you that the brake must be pressed to shift.

## ENGINE SWITCHING OFF

The system requires the gear lever to be positioned at P before extracting the key from the ignition device. It is advisable to put the lever in P before

stopping the engine and extract the key.

If the vehicle battery is flat and the ignition key is engaged, the latter is locked in position. To remove the key manually see the "Automatic transmission lever release" chapter in the "In case of emergency" section.

## TRANSMISSION EMERGENCY FUNCTION

(where provided)

Transmission function is monitored electronically for abnormal conditions. If a condition that might damage the transmission is detected, the "transmission emergency" function is activated.

In this condition, the transmission stays in 4<sup>th</sup> gear, regardless of the selected gear.

Positions P, R and N still work. Icon  might light up on the display.

In the event of a "transmission emergency" immediately contact the nearest Fiat Dealership.

### Temporary failure

In the event of a temporary failure, correct transmission operation can be restored for all the forwards gears by proceeding as follows:

- ❑ stop the vehicle;

- ❑ put the lever in P;
- ❑ turn the ignition device to the STOP position;
- ❑ please wait for about 10 seconds, then restart the engine;
- ❑ shift into the desired gear range. If the problem is no longer detected, the transmission will return to normal operation.

**WARNING** In the event of a temporary failure it is in any case recommended to contact a Fiat Dealership as soon as possible.

## WARNINGS

Failure to comply with what is reported below may damage the transmission:

- ❑ select position P (Park) only with the vehicle at a standstill;
- ❑ select position R (Reverse), or pass from R to another position only with the vehicle at a standstill and engine idling;
- ❑ do not shift gears between positions P (Park), R (Reverse), N (Neutral) or D (Drive) with engine running at a speed above idling. Before engaging any gear position, fully depress the brake pedal;
- ❑ keep the brake pedal pressed while moving the gear lever in a position different from P (Park);
- ❑ unexpected movement of the vehicle can injure the occupants or people nearby. Do not leave the vehicle with

engine running: before getting out of the passenger compartment always engage the parking brake, bring the gear lever to P (Park), switch off the engine and extract the key from the ignition device (for versions with mechanical key). With ignition device at STOP (key extraction allowed), the transmission is locked in position P (Park), to prevent any accidental movement of the vehicle;

❑ when getting out of the vehicle, always remove the mechanical key (where provided) from the ignition device and close all the doors. Do not leave children unattended inside the vehicle;

❑ bringing the transmission to a position different from P (Park) or N (Neutral) at an engine speed higher than idling is dangerous; if the brake pedal is not fully pressed, the vehicle could rapidly accelerate. Only engage the gear with engine at idling, fully depressing the brake pedal;

❑ if the transmission temperature exceeds the normal operating limits, the transmission control unit may change the gear engagement order and reduce the drive torque.

❑ if the transmission overheats the fluid overheating icon appears on the display. In this case the transmission





could operate incorrectly until it cools down;

□ when using the vehicle with extremely low external temperatures, the transmission operation may change according to engine temperature and vehicle speed: activation of the higher gears could be inhibited until the transmission oil is correctly warmed up; this function accelerates engine and transmission warming up. Complete operation of the transmission will be enabled as soon as the oil temperature reaches the predefined value.



### IMPORTANT

**138)** Never use position P instead of the parking brake. Always engage the parking brake when parking the vehicle to prevent injury or damage caused by the unexpected movement of the vehicle.

**139)** If the P position is not engaged, the vehicle could move and injure people. Before leaving the vehicle, make sure that the gear lever is in position P and that the parking brake is engaged.

**140)** Do not shift the gear lever to N and do not stop the engine when driving on a downhill road. This type of driving is dangerous and reduces the possibility of intervening in the case of variation of the road traffic or surface. You risk losing control of the vehicle and causing accidents.

**141)** Before moving the gear lever from position P, bring the ignition device to position MAR and press the brake pedal. Otherwise, the gear lever may get damaged.

**142)** Engage reverse only with the vehicle stationary, engine at idling speed and accelerator fully released.

**143)** Never leave children unattended in the vehicle. In addition, always remove the ignition key when leaving the vehicle and take it out with you.



### WARNING

**45)** If the vehicle is on a slope, always engage the parking brake BEFORE moving the shift lever to the P position.

**46)** If the vehicle is on a slope, always engage the electric parking brake BEFORE moving the shift lever to the P position.

**47)** Engage reverse only with the vehicle stationary, engine at idling speed and accelerator fully released.

## "DRIVE MODE" FUNCTION

(for versions/markets, where provided)

The function, in combination with the automatic transmission, can be used to set three different driving modes ("vehicle response") according to the driver's needs and road conditions: "Normal", "Power" or "Eco".

The mode is selected by pressing button (A) fig. 207 on the dashboard.

The selected mode is displayed on the instrument panel display (A) fig. 208 or fig. 209.

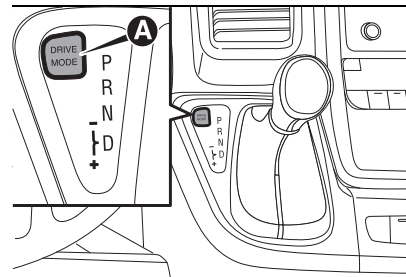

207

F1A0666



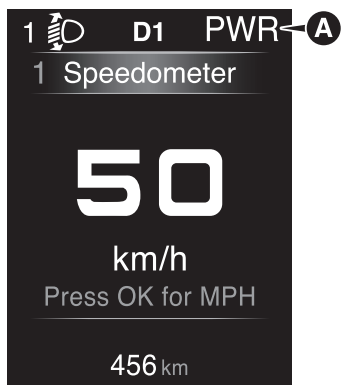

208

F1A0893

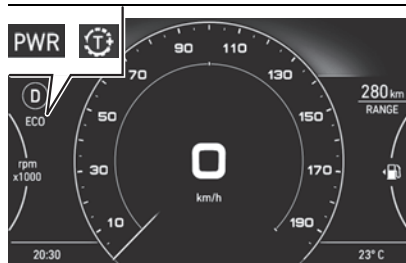

209

F1A0899

The "Drive Mode" function, using the on-board electronics, acts on the transmission and interfaces with the

instrument panel. Engagement by the function of the required driving mode is indicated on the instrument panel display.

"Normal" mode is automatically set when the engine is started.

### FAULT INDICATIONS

In the event of a fault in the function or selector, mode change is automatically disabled. In this case, "Normal" mode will be set automatically.

## START&STOP SYSTEM

### IN BRIEF

*The Start&Stop device automatically stops the engine each time the vehicle is stationary and all the conditions for automatic switch-off have been met, and starts it again when the driver wants to move off. This improves the efficiency of the vehicle by reducing fuel consumption, the emission of harmful gases and noise pollution.*

### OPERATING MODE

#### Stopping the engine

#### Versions with manual transmission

With the vehicle stationary, the engine

stops with the transmission in neutral and the clutch pedal released.

**NOTE** The engine can only be stopped automatically after exceeding about 7 km/h, to prevent the engine from being repeatedly stopped when driving at walking pace. Engine stopping is signalled by the (A) icon on the display.

#### Versions with automatic transmission

With vehicle at a standstill and brake pedal pressed, the engine switches off if the gear lever is in a position other than (R).

**NOTE** On versions with automatic transmission in the event of stops uphill, the engine switching off is disabled to activate the "Hill Holder" function (works only with running engine).

**NOTE** After automatic restarting, for the Stop&Start system to intervene again simply move the vehicle (at speed higher than 0.5 km/h for versions with automatic transmission or 7 km/h for versions with manual transmission). The warning light on the instrument panel switches on to signal that the engine has stopped

#### Restarting the engine

#### Versions with manual transmission

Depress the clutch pedal to restart the engine.



### Versions with automatic transmission

To restart the engine, release the brake pedal. The icon (A) on the display switches off. With brake pressed, if the gear lever is in automatic mode - D (Drive) - the engine can be restarted by moving the lever to R (Reverse) or N (Neutral). With the brake pedal pressed, if the gear lever is in "AutoStick" mode, the engine can be restarted by moving the lever to "+", "-", R (Reverse) or N (Neutral).

When the engine has been stopped automatically, keeping the brake pedal pressed, the brake can be released keeping the engine off by quickly shifting the gear lever to P (Park). To restart the engine, just move the lever out of position P.

### MANUAL ACTIVATION AND DEACTIVATION OF THE SYSTEM

To activate/deactivate the system manually, press the (A) fig. 210 button on the dashboard control trim.

#### Start&Stop system activation

A message will appear on the display when the Start&Stop system is activated.

#### Start&Stop system deactivation

A message will appear on the display when the Start&Stop system is off.

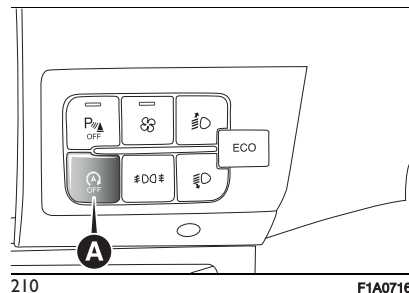

### MISSED ENGINE STOPPING CONDITIONS

With the device activated, for reasons of comfort, limiting emissions and safety, the engine does not stop in certain conditions, including:

- engine still cold;
- particularly cold external temperatures, if the corresponding indication is provided;
- battery not sufficiently charged;
- particulate filter regeneration in progress (diesel engines only);
- driver's door not shut;
- driver's seat belt not fastened;
- reverse gear engaged (for example, for parking manoeuvres);
- automatic climate control, if a suitable thermal comfort level has not

yet been reached or MAX-DEF function activation;

- during the first period of use, to initialise the system;
- if the Hill Descent Control system is active.



### RESTARTING CONDITIONS

For reasons of comfort, limiting harmful emissions and safety purposes, the power unit can restart automatically without any action on the part of the driver if certain conditions are met, including:

- battery not sufficiently charged;
- reduced braking system vacuum (e.g. if the brake pedal is pressed repeatedly);
- vehicle in motion (e.g. when driving on roads with a gradient);
- stopping the engine through the Start&Stop system for more than about three minutes.
- automatic climate control system for adjusting the thermal comfort level or to enable MAX-DEF function.

With a gear engaged, the engine can be automatically restarted only by fully depressing the clutch pedal.

**NOTE** In cases of undesired engine stops, due for example to the clutch pedal being released abruptly with a gear engaged, if the Start&Stop

system is activated, the engine can be restarted by fully depressing the clutch pedal or by placing the gear lever in neutral.

**NOTE** If the clutch is not pressed, when three minutes have elapsed since the engine was stopped, the engine can only be restarted using the key.

### SAFETY FUNCTIONS

In engine cut-out conditions through the Start&Stop system, if the driver unfastens his/her seat belt and opens the driver's door or the passenger door, the engine can be restarted only by using the key.

The driver is notified of this condition both by a buzzer and the flashing of the warning light (A) on the instrument panel.

### ENERGY SAVING FUNCTION

(for versions/markets, where provided) If, after the engine has been automatically restarted, the driver does not take any action for a period of about 3 minutes, the Start&Stop system will definitively stop the engine to avoid fuel consumption. The engine can only be started using the key in such cases.

**NOTE** In any case, it is possible to keep the engine running by deactivating the Start&Stop system.

### IRREGULAR OPERATION

In the event of malfunction, the Start&Stop system is deactivated. The driver is informed of the fault by the turning on of the icon (A). In this case, contact a Fiat Dealership.

### VEHICLE INACTIVITY

In the event of vehicle inactivity, special attention must be paid to the disconnection of the battery power supply.

The procedure must be performed by disconnecting the connector (A) from the sensor (C) monitoring the battery conditions, on the negative pole (D) of the battery. This sensor should never be disconnected from the pole except if the battery is replaced.

**WARNING** After turning the ignition key to STOP, wait at least 1 minute before disconnecting the electrical supply to the battery.

 144) 145)

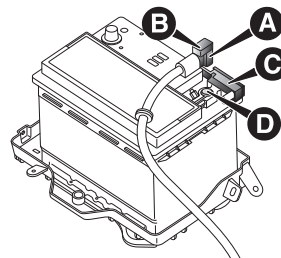

211

F1A0137



### IMPORTANT

**144)** The vehicle should always be evacuated after the key has been removed or turned to the STOP position. When refuelling, make sure that the vehicle is switched off with the key in the STOP position.

**145)** If the battery needs to be replaced, always contact a Fiat Dealership. Replace the battery with a new one of the same type and specifications.



### WARNING

**48)** If the vehicle is equipped with manual climate control, if you want to favour climate comfort, the Start&Stop system can be deactivated for continuous climate control system operation.



## ECO FUNCTION

(For versions/markets, where provided)  
To activate the function press the **ECO** (A) fig. 212 button. When the function is on, an icon is shown on the instrument panel display.

This function is memorised, so when the vehicle is started again, the system keeps the setting it had before the engine was stopped. Press the **ECO** button again to disable the function and restore the normal driving setting. In the event of a malfunction with the function on, the system automatically disables the **ECO** function and restores the normal driving setting.

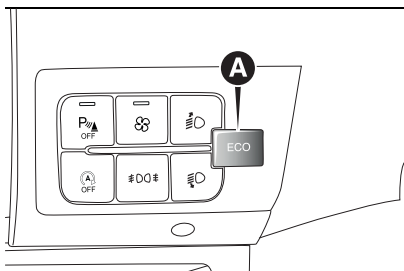

212

F1A0700

## SPEED LIMITER

(where provided)

### DESCRIPTION

This device allows the vehicle speed to be limited to a value set by the driver.

The maximum speed can be set both with vehicle stationary and in motion.

The minimum speed that can be set is 30 km/h.

When the device is active, the vehicle speed depends on the accelerator pedal, until the programmed speed limit is reached (see "Speed limit programming" paragraph).

### ACTIVATING THE DEVICE

To activate the device press button (A) on the steering wheel fig. 213.

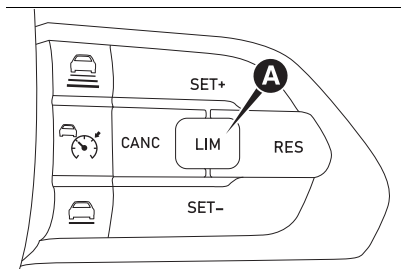

213

F1A0732

When the device is enabled, it is indicated by the "LIM" symbol being shown on the display along with the last speed set.

If the Adaptive Cruise Control has been activated previously, button (A) fig. 213 must be pressed twice. The first press switches off the function activated previously; the second press activates the Speed Limiter.

### SPEED LIMIT PROGRAMMING

The speed limit can be programmed without necessarily activating the device.

*To store a speed value higher than the displayed one, briefly press the SET + button. Each time the button is pressed, the speed increases by about 1 km/h while keeping the button pressed, the speed increases by 10 km/h.*

*To store a speed value lower than the displayed one, press the SET - button. Each time the button is pressed, the speed decreases by about 1 km/h while keeping the button pressed, the speed decreases by 10 km/h.*

### DEVICE ACTIVATION/DEACTIVATION

Device activation: press the SET + or SET - buttons.

The activation of the device is indicated by the green "LIM" symbol on the display.

Device deactivation: press the CANC button. The last set speed is crossed out and displayed in grey.

Device reactivation: press the RES button. The last set speed will be restored.

## EXCEEDING THE PROGRAMMED SPEED

By fully depressing the accelerator pedal, the programmed speed can be exceeded even with the device active (e.g. in the event of overtaking).

The device is disabled until the speed drops below the set limit, after which it reactivates automatically.

## DEACTIVATING THE DEVICE

To disengage the system press button (A) fig. 213.



**WARNING** The activation of the Adaptive Cruise Control will deactivate the device.

### Automatic off of the device

The device switches off automatically in the event of a system failure and the grey "LIM" symbol appears on the display. In this case, contact a Fiat Dealership.

## ELECTRONIC CRUISE CONTROL

This is an electronically controlled driving assistance device that allows the desired vehicle speed to be maintained, without having to press the accelerator pedal. This device can be used at a speed above 30 km/h on long stretches of dry, straight roads with few variations (e.g. motorways). It is therefore not recommended to use this device on extra-urban roads with traffic. Do not use the device in town. The electronic Cruise Control buttons are located on the right side of the steering wheel.



To ensure correct operation, the electronic Cruise Control is designed to deactivate if more than one function is operated simultaneously. In this case the system can be reactivated pressing button  or  and setting the desired speed of the vehicle.

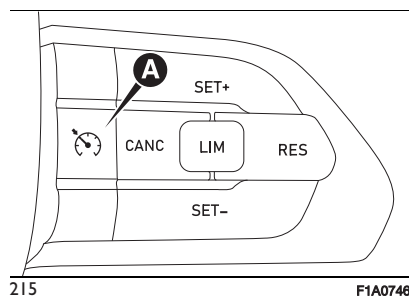
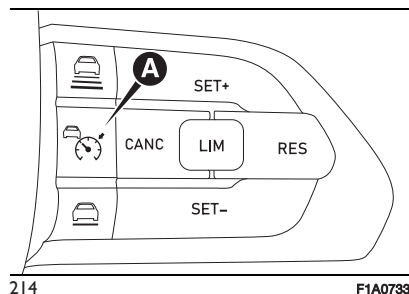

## ACTIVATING THE DEVICE

To activate the device, press the button (A) fig. 214 or (A) fig. 215, depending on the version.

 146) 147) 148)



The symbol  or  on the instrument panel switches on to signal that the device has been activated.

On versions with Speed Limiter, if the device is activated, button  or  must be pressed twice to activate the Cruise Control (because the first press deactivates the Speed Limiter, and the second press activates the Cruise Control).

The device cannot be turned on in either reverse or in neutral.



**WARNING** It is dangerous to leave the device on when it is not used. There is a risk of inadvertently activating it and losing control of the vehicle due to unexpected excessive speed.

## SETTING THE DESIRED SPEED

Proceed as follows:

□ operate the device (see the previous instructions);

□ when the vehicle has reached the desired speed, press button SET + (or SET -) and release it to activate the device. When the accelerator is released, the vehicle will keep the selected speed automatically.

If needed (when overtaking for instance), you can accelerate simply by pressing the accelerator; when you release the pedal, the vehicle goes back to the speed stored previously.

When travelling downhill with the device active, the vehicle speed may slightly exceed the stored one.

**WARNING** Before pressing the SET + (or SET -) buttons, the vehicle must be travelling at a constant speed on a flat surface.

## INCREASING / DECREASING SPEED

### Increasing speed

Once the electronic Cruise Control has been activated, the speed can be increased by pressing button SET +. Keeping the button pressed, the set speed will increase until the button is released, then the new speed will be stored.

Each time button SET + is pressed the set speed will be fine tuned.

### Decreasing speed

With the device activated, the speed can be decreased by pressing button SET -.

Keeping the button pressed, the set speed will decrease until the button is released, then the new speed will be stored.

Each time button SET - is pressed the set speed will be fine tuned.

**WARNING** Pressing the button SET + (or SET -) the speed is adjusted depending on the selected unit of measurement ("metric" or "imperial") set through the Menu of the instrument panel display or, depending on the versions, in the menu of **Uconnect™** (see "Settings" in the "Vehicle mode" paragraph in the "Multimedia" section).

**WARNING** On steeply sloping roads, the system may not be able to maintain the set speed, which may increase the speed of the vehicle. It is, therefore, preferable to switch the device off under these conditions. The device keeps the speed stored even uphill and downhill. A slight variation in the speed on slight rises is completely normal.



## RECALLING THE SPEED

With transmission operating in D (Drive), press and release the RES button to recall the previously set speed.

## DEACTIVATING THE DEVICE



Pressing the CANC button or pressing the brake pedal as the vehicle is slowing down deactivates the electronic Cruise Control without deleting the stored speed.

The Cruise Control can also be deactivated if the electric parking brake (EPB) is activated or if the braking system (e.g. the ESC system) or Cross Wind Assist (CWA) system intervenes as well as in other particular conditions. The stored speed is deleted in the following cases:

□ pressing button  or  or switching off the engine;

❑ if there is a malfunction in the electronic Cruise Control.

## DEACTIVATING THE DEVICE

The electronic Cruise Control device is deactivated by pressing button  or  bringing the ignition device switch to STOP.



### IMPORTANT

**146)** While driving with the device active, never move the gear lever to neutral.

**147)** In case of a malfunction or failure of the device, contact a Fiat Dealership.

**148)** The electronic Cruise Control can be dangerous if the system cannot keep a constant speed. In specific conditions speed may be excessive, resulting in the risk of losing control of the vehicle and causing accidents. Do not use the device in heavy traffic or on winding, icy, snowy or slippery roads.

## ENGINE IDLE PRESET

(for versions/markets, where provided)

The engine idle speed setting is a feature that allows you to manually set the engine idle speed through a dedicated menu on the instrument panel ("Idle Preset" menu) that can be used to enable/disable the feature ("Idle Preset Activation" menu) and set the desired idle speed value ("Idle Speed Selection" menu).

The function is usually used in case of:

- ❑ "Power Take-Off" connection;
- ❑ heating of the engine and/or the passenger compartment.

## ENABLING/DISABLING THE ENGINE IDLE SPEED SETTING

Using the control buttons located on the left side of the steering wheel, it is possible to access the menu ("Idle Preset Activation") to enable/disable the idle speed setting.

This menu item allows you to enable/disable the feature by selecting one of the following options:

- ❑ "ON"
- ❑ "OFF"

NOTE The preset idling speed is 900 rpm.

The driver can modify this value using the dedicated menu ("Idle speed selection").

Selecting the "ON" option to set the engine idle speed to the previously stored value.

The engine idle speed setting can be enabled if the following conditions are met:

- ❑ parking brake applied;
- ❑ clutch pedal released (for versions with manual transmission);
- ❑ brake pedal released;
- ❑ clutch pedal pressed and released at least once during the key-on cycle (for versions with manual transmission);
- ❑ gear shift lever in position P (for versions with automatic transmission).

A dedicated message indicating unavailability will be displayed on the instrument cluster display if you attempt to activate the feature (by selecting the "ON" option from the menu) when not all of the conditions listed above are met.

The feature can be disabled by selecting the OFF option in the "Idle Preset Activation" menu.

A message will appear on the instrument panel display when the function is deactivated by the driver.





## INCREASING/DECREASING AND STORING ENGINE IDLE PRESET

It is possible to access the menu to set the desired engine idle speed ("Idle speed selection") using the control buttons located on the left side of the steering wheel.

This menu item allows you to set the desired value for minimum engine speed using the control buttons:

- ▣ minimum: 900 rpm
- ▣ maximum: 2200 rpm
- ▣ increase/decrease: 50 rpm

The system stores the current engine idling speed as a new preset value.

## SPEED BLOCK

(for versions/markets, where provided)

The vehicle is equipped with a speed limitation function that can be set on the user's request to one of four default values: 90, 100, 110, 130 km/h.

To activate/deactivate this function, contact a Fiat Dealership.

Following the operation, a sticker will be applied to the windscreen showing the top speed setting.

**IMPORTANT** The speedometer could indicate a higher maximum speed than the effective one, set by the Dealership, in accordance with the regulations in force.

## PARKSENSE SYSTEM

(where provided)



149)

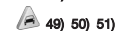

49) 50) 51)

### VERSIONS WITH 4 SENSORS

The parking sensors, located in the rear bumper fig. 216, are used to detect the presence of any obstacles near the rear part of the vehicle. The sensors warn the driver about the presence of obstacles with acoustic warning and, where provided, also with visual indications on the instrument panel display.

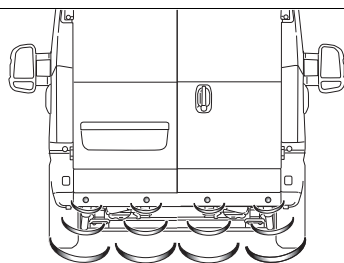

216

F1A0134

### System activation/deactivation Activation

The system is automatically activated when reverse is engaged.

### Deactivation

The system is automatically deactivated whenever a gear other than reverse is engaged.

### Acoustic warning

When reverse is engaged and there is an obstacle behind the car, an acoustic warning with variable frequency is activated:

- ▣ increases as the distance between the vehicle and the obstacle decreases;
- ▣ becomes continuous when the distance between the vehicle and the obstacle is less than 30 cm and stops if the distance increases;
- ▣ remains constant if the distance between the vehicle and the obstacle remains unchanged. If this situation concerns the exterior sensors, the signal will stop after approximately 3 seconds to avoid, for example, indications in the event of manoeuvres along a wall.

If several obstacles are detected by the sensors, only the nearest one is considered.

### Warning on display

The warnings regarding the **ParkSense®** system are shown on the instrument panel display only if the "Acoustic warning and display" item in the "Settings" menu is selected



(see "Settings" in the "Vehicle mode" paragraph in the "Multimedia" section). In addition to the acoustic warning, the system indicates the presence of an obstacle in the rear area by displaying a single arc in one of the possible areas, in accordance with the distance of the object and the position in relation to the vehicle.

If several obstacles are detected simultaneously in the rear area, the display will show all of them, regardless of the area in which they were detected.

The colour on the display depends on the distance from and position of the obstacle.

### Operation with trailer

The operation of the sensors is automatically deactivated when the plug for the electric cable for the trailer is inserted in the vehicle tow hook socket. The sensors are automatically reactivated when the trailer's cable plug is removed.

### VERSIONS WITH 14/16 SENSORS

The parking sensors, located in the front bumper fig. 217, rear bumper fig. 218 and on the sides fig. 219 are used to detect the presence of any obstacles in the vicinity of the vehicle (the system may not be able to cover

the entire surface of the sides of the vehicle and some signals may be delayed).

The sensors warn the driver about the presence of obstacles with acoustic warning and, where provided, also with visual indications on the instrument panel display.

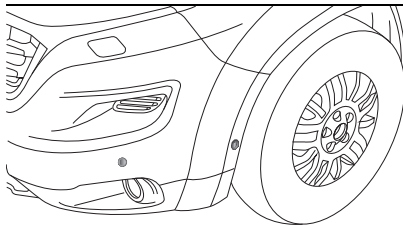

217

F1A0701

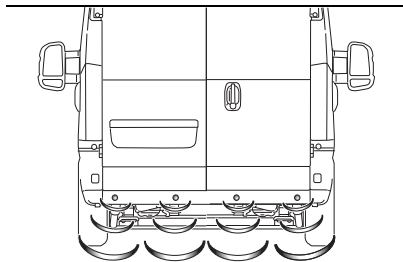

218

F1A0134

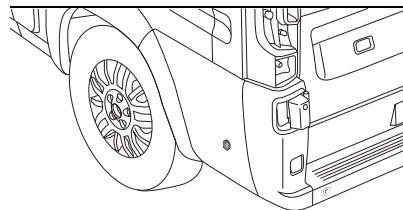

219

F1A0702

### Engagement / disengagement

To disengage the system press button (A) fig. 220.

When the system passes from engaged to disengaged and vice versa, it is always accompanied by a dedicated message on the instrument panel display.

The LED on the button is off when the system is switched on by the driver. The LED is on if the system is deactivated by the user, faulty or temporarily deactivated.

If the button is pressed with a system failure, the LED flashes for a few seconds, then it stays on constantly.

After the **ParkSense**® system has been disengaged, it will stay in this condition until the following engagement, even if the ignition device passes from MAR to STOP and then again to MAR.



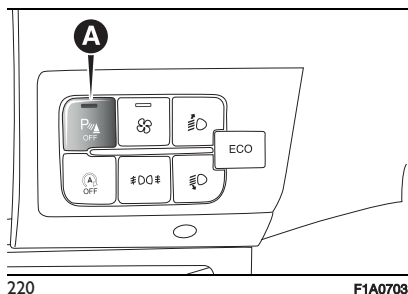

220

F1A0703

### System activation/deactivation Activation

With the system active, the acoustic and visual signals are activated automatically in the following cases:

- when forward gear is selected (versions with manual transmission) or D (Drive) position (versions with automatic transmission) and an obstacle is detected;
- or
- when reverse gear is selected (versions with manual transmission) or R position (versions with automatic transmission);
- or
- when the manual transmission gear lever is in neutral or the automatic transmission lever is in N (neutral) position, the vehicle is moving and an obstacle is detected.

### Deactivation

The acoustic and visual signals are deactivated automatically in the following cases:

- engaging a gear other than reverse gear at a speed above 18 km/h;
- or
- exceeding 11 km/h with reverse gear engaged;
- or
- when with the vehicle standing the manual gear stick is in neutral or the automatic transmission lever is in P (Park) or N (Neutral) position.

### Acoustic warning

When the sensors detect an obstacle within the trajectory of the vehicle, an acoustic warning is activated with a frequency that increases as the distance from the obstacle decreases and then becomes a continuous tone when this distance becomes less than about 30 cm.

The acoustic warning is interrupted in the following situations:

- when external sensors detect an obstacle at a constant distance (example: manoeuvring along a wall);
- if vehicle is at a standstill with the transmission in a position other than reverse;

- when the obstacle is not within the trajectory of the vehicle.
- If the sensors detect several obstacles at the same time, in the front, side and rear area, the acoustic warning of the obstacle in the nearest trajectory is reproduced.

### Warning on display

The warnings regarding the system are shown on the instrument panel display only if the "Acoustic warning and display" item in the "Settings" menu of the system is selected (see "Settings" in the "Vehicle mode" paragraph in the "Multimedia" section).

The system indicates the presence of an obstacle by displaying a single arc in one of the possible areas, in accordance with the distance of the object and the position in relation to the vehicle.

As the vehicle approaches an obstacle within the front, side or rear coverage area, the display will show a single arc in the corresponding area. The colour depends on the distance from and position of the obstacle.

If several obstacles are detected simultaneously in the front, side and rear area, the display will show all of them, regardless of the area in which they were detected.

## Operation with trailer

The operation of the rear sensors is automatically deactivated when the trailer's electric cable plug is inserted in the tow hook socket of the vehicle, while the front sensors stay active and can provide acoustic and visual warnings. In this case, the LED on the button (A) on the dashboard fig. 220 stays off. The rear sensors are automatically reactivated when the trailer's cable plug is removed.

## Fault indication

Parking sensor faults, if any, will be indicated by a message on the display (see description in the "Warning lights and messages" chapter in the "Knowing the instrument panel" section).

## Messages on the display

In case of system failure, a dedicated message is shown on the display for several seconds.

If the display shows messages requiring the front, side or rear sensor cleaning, make sure that the outer surface and the underside of the bumper is free of dirt (e.g. snow, mud, ice, etc.).

After performing this check, place the ignition device in STOP position, then turn it to position the MAR position and check whether the messages are no

longer displayed. If messages are still displayed, contact a Fiat Dealership.

## GENERAL WARNINGS

Some conditions may influence the performance of the parking system:

- ❑ reduced sensor sensitivity and a reduction in the parking assistance system performance could be due to the presence of: ice, snow, mud, thick paint, on the surface of the sensor;
- ❑ The sensor may detect a non-existent obstacle (echo interference) due to mechanical noises, for example when washing the vehicle, in case of rain (very strong wind), hail;
- ❑ the signals sent by the sensor can also be altered by the presence of ultrasonic systems (e.g. pneumatic brake systems of trucks or pneumatic drills) near the vehicle;
- ❑ parking assistance system performance can also be influenced by the position of the sensors, for example due to a change in the ride setting (caused by wear to the shock absorbers, suspension), or by changing tyres, overloading the vehicle or carrying out specific tuning operations that require the vehicle to be lowered;
- ❑ the presence of a tow hook without trailer, which may interfere with the correct operation of the parking sensors. Before using the **ParkSense**<sup>®</sup> system, it is

recommended to remove the removable tow hook ball assembly and the respective attachment from the vehicle when the latter is not used for towing operations. Failure to comply with this prescription may cause personal injuries or damage to cars or obstacles since, when the continuous acoustic warning is emitted, the tow hook ball is already in a position that is much closer to the obstacle than the rear bumper. If you wish to leave the tow hook fitted without towing a trailer is advisable to contact a Fiat Dealership

for the **ParkSense**<sup>®</sup> system update operations because the tow hook could be detected as an obstacle by the central sensors;

- ❑ the presence of adhesives on the sensors. Therefore, take care not to place stickers on the sensors;
- ❑ the rear footrest (where provided) must remain retracted to avoid false signals from the **ParkSense**<sup>®</sup> system;
- ❑ opening the driver's door, passenger door, side door and rear load compartment door causes the side detection system to be deactivated;
- ❑ the side indication starts at the side panel and does not take the size of the exterior mirrors into account.

When the vehicle is started, a side obstacle may not be detected if it is not near a side sensor.



**IMPORTANT**

**149)** Parking and other potentially dangerous manoeuvres are, however, always the driver's responsibility. When performing these operations, always make sure that there are no other people (especially children) or animals on the route you want to take. The parking sensors are an aid for the driver, but the driver must never allow their attention to lapse during potentially dangerous manoeuvres, even those executed at low speeds.

**WARNING**

**49)** The sensors must be clean of mud, dirt, snow or ice in order for the system to operate correctly. Be careful not to scratch or damage the sensors while cleaning them. Avoid using dry, rough or hard cloths. The sensors should be washed using clean water with the addition of car shampoo if necessary. When using special washing equipment such as high pressure jets or steam cleaning, clean the sensors very quickly keeping the jet more than 10 cm away.

**50)** Have interventions on the bumper in the area of the sensors carried out only by a Fiat Dealership. Interventions on the bumper that are not carried out properly may compromise the operation of the parking sensors.

**51)** Only have the bumper repainted or any retouches to the paintwork in the area of the sensors carried out by a Fiat

*Dealership. Incorrect paint application could affect the operation of the parking sensors.*

## **AUTOMATIC PARK ASSIST - ACTIVE PARKSENSE SYSTEM**

(where provided)

**WARNING** The complete manoeuvre is the responsibility of the driver.

The system helps the driver to find a suitable free parallel parking space between vehicles according to the width or length of the vehicle and automatically manages the steering wheel movement during manoeuvring. The system also helps the driver manoeuvre out from a parallel parking space.

### **SENSORS**

The system uses the front, rear and side sensors located in the front fig. 221 and rear fig. 222 bumper and on the sides of the vehicle fig. 223.

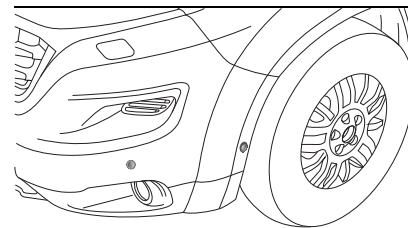

221

F1A0701

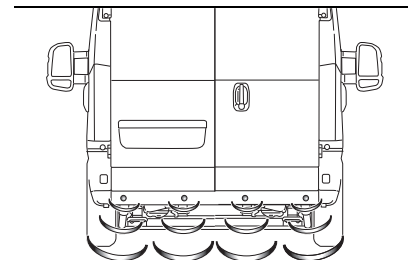

222

F1A0134

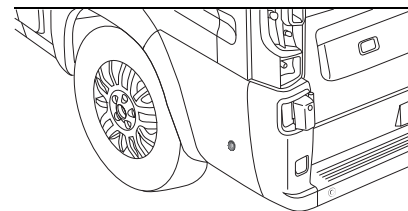

223

F1A0702

## ENGAGEMENT / DISENGAGEMENT

To activate the system, press button (A) fig. 224 the instrument panel display will show the instructions about the manoeuvre.

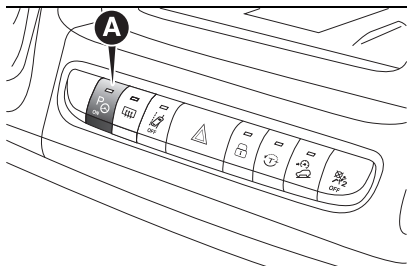

224

F1A0706

**System on:** LED lighted continuously.

**System off:** LED off.

The LED also lights up in the event of a failure in the **Active ParkSense®** (Automatic Park Assist) system. If the button is pressed with the system faulty, the LED flashes for a few seconds, then it stays off.

**WARNING** The use of wheels of a different size to those at the time of purchase of the vehicle could affect the system and prevent correct operation.

## SYSTEM OPERATION



When searching for a parking place, the system uses the side sensors, which are automatically activated with engine on and speed below 30 km/h.

During the manoeuvre the driver is also assisted by information from the parking sensors which indicate the distance when approaching obstacles in front of, behind and by the side of the vehicle.

If the driver activates the Active ParkSense® function after having previously deactivated the ParkSense® function, the sensors are activated once more and stay in this operating condition only during the parking manoeuvre.

## PARALLEL AND PERPENDICULAR PARKING DESCRIPTION

### Activation

Press the button on the dashboard: after being selected, the system activates search mode. Considering that the system recognises parking places even when it has not been selected, it can be activated even immediately after passing close to a parking place suitable for the type of car. The system will inform the driver, through the instrument panel display,

about the operations to be performed for a correct manoeuvre.



### Selecting the type of parking

During the search and until the reverse gear is engaged, the preferred type can be selected for parking:

- "Parallel"*: the vehicle will search a parking place parallel to the travel direction;
- "Perpendicular"*: the vehicle will search a parking place perpendicular to the travel direction.

### Selection of the search side

To select the search side and perform the correct manoeuvre, act as follows:

-  Select the search for the parking place and the manoeuvre on the passenger side placing the direction indicator in centre position (off) or with the direction indicator in the required direction.
-  Select the search for the parking area and manoeuvre on the driver side pushing the direction indicator in the required direction.

### Search for a parking place



Through the side sensors, the system continuously searches for a free parking place, suitable for the dimensions of the vehicle.



While searching the vehicle should continue following the lane at a speed of below 30 km/h and at a distance of around 50 cm to 1.5 m from parked vehicles for parallel parking fig. 225.

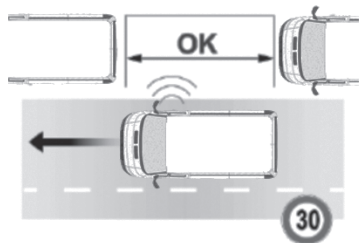

225

F1A0853

For perpendicular parking, on the other hand, it is necessary to keep a distance of approximately 1 m to 2 m fig. 226.

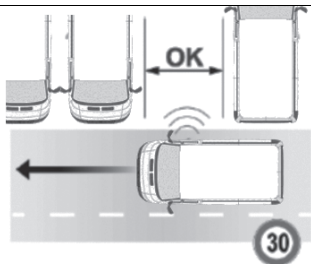

226

F1A0855

A parking space is considered suitable if it is approximately 1 m longer or wider compared to the vehicle dimensions.

**WARNING** While searching, vehicle speed should not exceed 30 km/h; when 25 km/h have been reached, the driver is asked to decrease the speed; if the speed of 30 km/h is exceeded, it is deactivated (in this case, the system can be restarted by pressing the button on the dashboard).

### Manoeuvre

During manoeuvre (fig. 227, fig. 228), the movements of the vehicle can be controlled by operating the accelerator, brake and clutch pedals (versions with manual transmission), or the accelerator and brake pedals (versions with automatic transmission). Once a parking place has been found, you will be asked to engage reverse, leave the steering wheel and use the pedals, while the system handles the steering operation in the dedicated area.

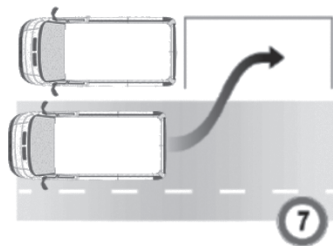

227

F1A0854

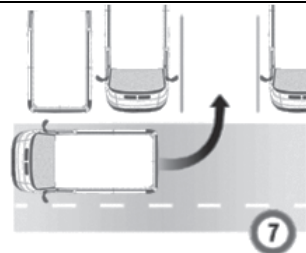

228

F1A0856

During the manoeuvre, all information coming from parking sensors can be used (follow the indications on the instrument panel), while it is anyway recommended keep a visual control over the surrounding area.

The vehicle can be stopped during the manoeuvre and, whilst remaining stationary, reverse gear can temporarily be released (for example, to allow a pedestrian to go by in the area of the manoeuvre).

The parking manoeuvre will be interrupted in the following cases:

- if the vehicle speed is greater than 7 km/h;
- the steering is (voluntarily or unintentionally) moved (by grabbing it or preventing it from moving);
- the slope of the road, uneven road surface or obstacles before the wheels, affect the movement of the vehicle,

thus preventing it from following the correct path.

**WARNING** Manoeuvring is deactivated if, after about 3 minutes, parking has not been completed.

## End of manoeuvre



The semi-automatic manoeuvre ends when the display on the instrument panel shows the message of completed manoeuvre.

At the end of the manoeuvre, the driver resumes control of the vehicle and, if necessary, must complete parking manually.

## DESCRIPTION OF MANOEUVRING OUT FROM PARALLEL PARKING

(where provided)

### Activation

The vehicle must be stationary in the parking place for the "Manoeuvring out from a parking place" function to be activated correctly by pressing the button on the dashboard fig. 229.

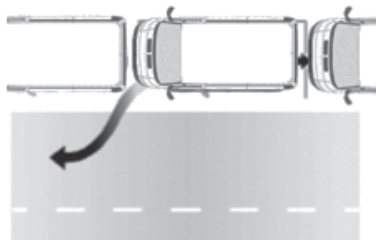

229

F1A0857

### Selection of the exiting side

Proceed as follows to perform the manoeuvre:

- select to manoeuvre on passenger side by moving the direction indicator towards the required side;
- select to manoeuvre on the driver side by moving the direction indicator to the required side.

The manoeuvre is aborted if the selected side is occupied.

The system will inform the driver by displaying messages on the instrument panel display about the side on which the exiting manoeuvre will be performed.

### Manoeuvre

The driver will be asked to engage reverse, leave the steering wheel and use the pedals, while the system handles the steering automatically to

manoeuvre the car out of the parking place.

The driver controls the movements of the vehicle using accelerator, brake and clutch pedals (versions with manual transmission) or accelerator and brake pedals (versions with automatic transmission).

The parking sensors must detect a front obstacle (positioned at a maximum distance of approximately 200 cm from the front bumper) and a rear obstacle (positioned at a maximum distance of approximately 200 cm from the rear bumper) and the selected exit side free for the system to be able to manoeuvre. It is not possible for the system to carry out the manoeuvre if the overall parking space (front + rear), excluding the length of the vehicle, is less than about 1 m. In this condition, the manoeuvre is not performed and a dedicated message appears on the display.

### GENERAL WARNINGS

- If the sensors undergo impact which alters their position, the system operation could deteriorate considerably.
- The system reaches top performance after the vehicle has covered about 50 km (system "self-calibration").





- ❑ If the sensors are dirty, covered by snow, ice or mud or are repainted vs. the original conditions, the system operation could result strongly degraded. It is extremely important that the sensors are always clean in order for the system to operate correctly. During cleaning make sure not to scratch or damage them; avoid using dry or rough cloths. The sensors should be washed using clean water with the addition of car shampoo if necessary. In washing stations, clean the sensors quickly, keeping the steam jet/high pressure washing nozzles at least 10 cm away from the sensors.
- ❑ Ultrasonic sound sources (e.g. pneumatic brakes of trucks or air drills) nearby could negatively influence the sensor performance.
- ❑ Sensors may detect a non-existent obstacle (echo interference) due to mechanical noises, for example while washing of the vehicle, in the case of rain, strong wind, hail.
- ❑ The sensors may not detect objects of a particular shape or made from particular materials (very thin poles, trailer beams, panels, nets, bushes, parking deterrent posts, kerbs, rubbish bins, motor cars, etc.). Always pay the utmost care and make sure that the vehicle and its path are really

- compatible with the parking area detected by the system.
- ❑ The use of tyres (one or more) or rims with dimensions other than those installed on the vehicle at the factory could affect the system operation.
- ❑ If a trailer (with correctly engaged socket) is present, the system will be automatically disabled.
- ❑ In "Search in progress" mode, the system could incorrectly identify a parking place to carry out the manoeuvre (e.g. by a junction, driveways, roads crossing the travel direction, etc.).
- ❑ In the case of parking manoeuvres on roads on a gradient, the performance of the system could be inferior and it may deactivate.
- ❑ In the case of parking manoeuvres with the vehicle at full load on roads on a gradient, the performance of the system could be inferior and it may deactivate.
- ❑ If a parking manoeuvre is being carried out between two parked cars alongside the pavement, the system may cause the vehicle to mount the pavement.
- ❑ Some manoeuvres at very tight bends might be impossible to be carried out.
- ❑ Take great care to ensure that conditions do not change during the

- parking manoeuvre (e.g. if there are persons and/or animals in the parking place, moving cars, etc.) and intervene immediately if necessary.
- ❑ When parking, pay attention to the cars coming in the opposite direction.
- ❑ Always respect the Highway Code rules.

WARNING Correct system operation is not guaranteed if snow chains or the space-saver wheel are fitted.

WARNING The function only informs the driver about the last appropriate parking place (parallel or perpendicular) detected by the parking sensors.

WARNING Some messages displayed are accompanied by acoustic warnings.

WARNING The driver is required to follow the instructions of the system to perform a correct parking manoeuvre.

WARNING During the assisted parking manoeuvre may be interrupted due to insufficient space to finish.





## IMPORTANT

**150)** Parking and other dangerous manoeuvres are, however, always the driver's responsibility. While carrying out these manoeuvres, always make sure that no people (especially children) or animals are in the area concerned. The parking sensors are an aid for the driver, but the driver must never allow their attention to lapse during potentially dangerous manoeuvres, even those executed at low speeds.

**151)** The search for the parking space and the parking manoeuvres must be performed in compliance with the current regulations of the Highway Code.

**152)** If you wish to stop the steering wheel with your hands during a manoeuvre, it is advisable to handle it firmly on the outer rim. Do not try and keep your hands on the inside or hold the spokes.



## WARNING

**52)** The operation of the system is based on various components: front and rear parking sensors, side sensors, steering system, wheels, braking system and instrument panel. The malfunction of one of these components could compromise the operation of the system.

**53)** Only have the bumper repainted or any retouches to the paintwork in the area of the sensors carried out by a Fiat Dealership. Incorrect paint application could affect the operation of the parking sensors.

## REAR CAMERA (ParkView® Rear Backup Camera)

(where provided)

### DESCRIPTION

 153)

 54)

The rear view camera fig. 230 is located on the luggage compartment tailgate.

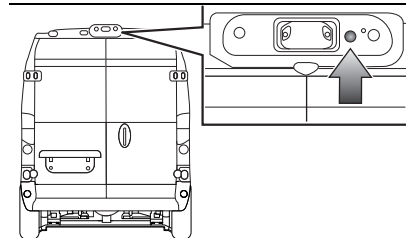

230

F1A0663

### Camera activation/deactivation

Every time reverse is engaged, the display fig. 231 of the **Uconnect™** system shows the area around the vehicle, as seen by the rear camera.

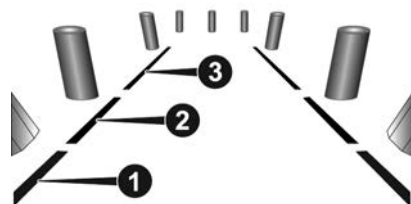

231

07186J0002EM

The images are shown on the display together with a warning message. With the "Camera delay" option active, when engaging the reverse gear, the image from the camera will continue to be displayed for up to 10 seconds after reverse is disengaged, unless vehicle speed is higher than 13 km/h, or:

- that the transmission lever is in neutral;
- the ignition device is in the STOP position.

When the shift lever is no longer in the reverse position, a button for deactivating the display of the image from the camera appears on the **Uconnect™** system display along with the images behind the vehicle, if the "Camera delay" setting is active on the **Uconnect™** system.

NOTE The displayed image may look a bit distorted.



**IMPORTANT**

**153)** *Parking and other potentially dangerous manoeuvres are, however, always the driver's responsibility. While carrying out these manoeuvres, always make sure that no people (especially children) or animals are in the area concerned. The camera is an aid for the driver, but the driver must never allow his/her attention to lapse during potentially dangerous manoeuvres, even those executed at low speeds. Always keep a slow speed, so as to promptly brake in the case of obstacles.*

**WARNING**

**54)** *It is vital, for correct operation, that the camera is always kept clean and free from any mud, dirt, snow or ice. Be careful not to scratch or damage the camera while cleaning it. Avoid using dry, rough or hard cloths. The camera must be washed using clean water, with the addition of vehicle shampoo if necessary. In washing stations which use steam or high-pressure jets, clean the camera quickly, keeping the nozzle more than 10 cm away from the sensors. Also, do not apply stickers to the camera.*

**SYMBOLS AND MESSAGES ON THE DISPLAY****Indications on the display**

If activated, using **Uconnect™** system settings, it is possible to activate the guidelines on the display. If activated, the grid is positioned on the image to highlight the width of the vehicle and the expected reversing path in accordance with the steering wheel position.

A superimposed central broken line indicates the centre of the vehicle to facilitate parking manoeuvres or tow hook alignment. The various coloured areas indicate the distance from the rear part of the vehicle.

The table below shows the approximate distances for each area fig. 231:

| Area       | Distance from the rear of the vehicle |
|------------|---------------------------------------|
| Red (1)    | 0 - 30 cm                             |
| Yellow (2) | 30 cm - 1 m                           |
| Green (3)  | 1 m or more                           |

**Messages on the display**

If the rear load compartment is open, the camera will not detect any obstacle in the rear part of the vehicle. The display will show a dedicated warning message.

In this case, close the load compartment using the handle, pressing it next to the lock until it clicks (see the "Doors" paragraph in the "Knowing your vehicle" chapter).

**TRAFFIC SIGN RECOGNITION**

The TSR (Traffic Sign Recognition) system is a driver assistance system that alerts the user to the most plausible road limits.

It is able to recognise both unconditional speed limits and those in rain, snow and fog (shown only when they are valid).

Where available, a speed limit of these types represents the applicable road limit, always visible at the top of each screen with a symbol. Example:



Road limits in other categories (e.g. time restrictions, exit signs, etc.) and the prohibition of overtaking are only visible in the "Driver Assist" screen of

the instrument panel (see the "Display" chapter in the "Knowing the instrument panel" section).

NOTE The rain, fog or snow type limits are only displayed if these conditions are likely to occur, i.e. if the windscreen wipers (in case of rain), the fog lights/fog lights (in case of fog) or the windscreen wipers with low external temperature (in case of snow) are activated.

The Traffic Sign Recognition system is automatically active when the vehicle is started.

Using the "Settings" menu of the **Uconnect™** system the user can:

❑ deactivate the system by removing the check mark from the relevant menu item

❑ select the type of signalling when the detected road limit is exceeded (off, visual, visual and acoustic signalling).

See the "Uconnect™" chapter in the "Multimedia" section for more information.

If Speed Limiter or Adaptive Cruise Control is active, the applicable road limit (unconditional or rain/snow/fog type) is made available and by pressing the RES button can be accepted as a speed for Intelligent Speed Assist or alternatively for Intelligent Adaptive Cruise Control .

The recognition of valid road limits depends very much on road conditions, the positioning of signs, visibility conditions and various other factors. The system supplies and reminds the driver of the most plausible road limit.

The TSR system cannot provide an applicable speed limit in the following cases:

❑ if an end-of-limit sign is recognised and if the navigator (where provided) is unable to provide a valid limit on that stretch of road. The symbol  appears on the display.

❑ in case of system fault or unavailability, the symbol  appears on the display.

NOTE In some cases, the system may show this symbol  when recalculating the route by the navigation system (where provided).

### With Uconnect™ without navigation system

The TSR system uses the camera, located in the central area of the windscreen fig. 232 and reminds the user of the last road limit recognised by the camera.

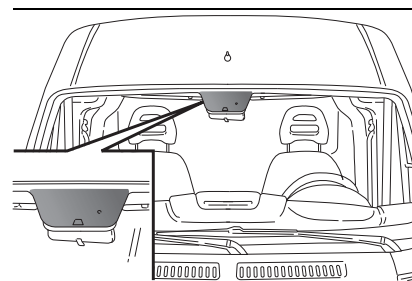

232

F1A0988

NOTE Without a navigator, the system cannot provide:

❑ the implicit limits (e.g. the general speed limit on motorways). In these cases the system can show the last road sign encountered (e.g. the speed limit of the entrance ramp);

❑ in general, the limit in force for a road where a speed limit sign was not previously encountered and correctly recognised.

After travelling a certain distance, the road limit symbol turns grey to indicate that it is no longer considered reliable by the system. Upon recognition of a new sign, the TSR symbol will become coloured again.

WARNING In the absence of a navigator, the system cannot recognise the unit of measurement of the country you are travelling in, but only the numerical value of the road sign



encountered along the road. The speed limit suggested and offered to Intelligent Speed Assist (ISA) and Intelligent Adaptive Cruise Control (IACC) systems (where active) is therefore intended according to the unit of measurement set by the user on the instrument panel display. Therefore, for the ISA and the IACC to be of practical help in complying with the limits in force, the driver must set the unit of measurement consistent with the country in which they are travelling.

### **With Uconnect™ with navigation system (Traffic Sign Information)**

When the navigator is present, the TSR system integrates the detections made by the camera with the information provided by the navigation system. Therefore, it can provide the implicit limits (e.g. the general speed limit on motorways) and to supplement with maps the limitations of recognition of road signs on the camera alone. The navigator tells the system of the unit of measurement in force in the country in which you are travelling and converts the value consistently with the unit of measurement selected by the user. In this way, the speed limitation suggested by the ISA system or the speed offered by the IACC system will always be correct, regardless of the

unit of measurement chosen by the user.

The system can display the shape of the signs consistently with the current shape of the country in which you are travelling.

Using the information contained in the navigator, the system can recognise motorway, urban and non-urban scenarios and to use the limits provided by the navigator to provide the most plausibly accurate speed limit. In addition, the system can recognise turns and provide, where necessary, the limit detected by the navigator in place of that recognised by the camera.

## **INTELLIGENT SPEED ASSIST**

---

The "Intelligent Speed Assist" system can be used to set a speed limit on the "Speed Limiter" system equal to the one detected on the road signs by means of the "Traffic Sign Recognition" system, signalled to the driver on the instrument panel display. The minimum speed that can be set is 30 km/h (20 mph).

The "Intelligent Speed Assist" system can be activated if the following systems are active:

- Speed Limiter (see the chapter in this section)
- Traffic Sign Recognition (see the chapter in this section)

When the "Intelligent Speed Assist" system recognises a new road sign, it will suggest the new speed limit to the driver with a specific message and dedicated alerts depending on whether the road sign is higher or lower than the current speed stored by the Speed Limiter. Consider both unconditional speed limits and those valid in rain, snow or fog to be valid for speed limitation.

You can confirm by pressing the RES button the speed limit setting equal to the suggested sign. Once the speed limit provided by the "Traffic

Sign Recognition" system has been acquired as the new Speed Limiter value, the activation of Intelligent Speed Assist is indicated by the symbol LIM on the display and the relevant road sign is shown surrounded by green.

## SYSTEM DEACTIVATION

The system is deactivated under the following conditions:

- when the Traffic Sign Recognition system is deactivated;
- when the Speed Limiter system is deactivated;
- when the Traffic Sign Recognition system shows a new speed limit which is not confirmed by the driver;
- when the Traffic Sign Recognition system shows the end of the speed limit;
- when the Traffic Sign Recognition system cannot display any speed limit.

## EXCEEDING THE PROGRAMMED SPEED

By fully depressing the accelerator pedal, the programmed speed can be exceeded even with the "Intelligent Speed Assist" system active (e.g. in the event of overtaking). The system is disabled until the speed drops below the set limit, after which it activates again automatically.

## ADAPTIVE CRUISE CONTROL (ACC)

(where provided)

 154) 155) 156) 157) 158) 159) 160)

 55) 56) 57) 58) 59) 60) 61)

## DESCRIPTION

The Adaptive Cruise Control (ACC) is a driver assist device which combines the Cruise Control functions with one for controlling the distance from the vehicle ahead.

The device allows to hold the vehicle at the desired speed without needing to press the accelerator. It also allows to hold a given distance from the vehicle ahead (the distance can be set by the driver).

The Adaptive Cruise Control (ACC) uses a radar sensor, located behind the front bumper fig. 233 and a camera, located in the middle area of the windscreen fig. 234, to detect the presence of a vehicle close ahead.

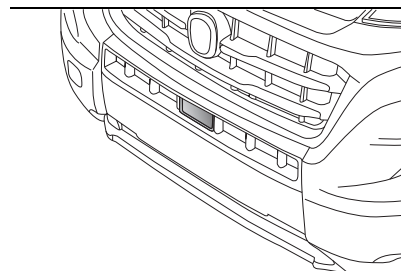

233

F1A0704

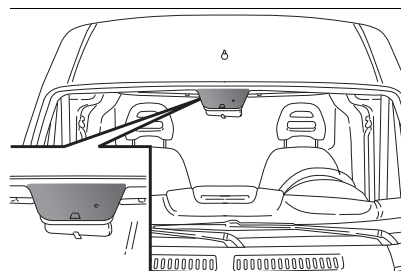

234

F1A0998

The device enhances driving comfort when on the motorway or out of town with light traffic.

The use of the device is therefore not advantageous on busy roads or in town.

## WARNINGS

If the sensor does not detect any vehicle ahead, the device will maintain a fixed set speed.

If the sensor detects a vehicle ahead, the device automatically intervenes



by braking (or accelerating) slightly in order not to exceed the original set speed, so that the vehicle keeps the preset distance, seeking to adapt to the speed of the vehicle ahead.

It is advisable to turn the device off in the following cases:

- ❑ driving in fog, heavy rain, snow, heavy traffic and in complex driving situations (e.g. on motorways with roadworks in progress);
- ❑ driving close to a bend (winding roads), icy, snowy, slippery roads or with a steep uphill or downhill slope;
- ❑ entering a turn lane or an off-ramp of the motorway;
- ❑ towing a trailer;
- ❑ when circumstances do not allow safe driving at a constant speed.

With “Adaptive Cruise Control”  mode engaged, an adequate distance between vehicles is maintained (the message “Adaptive Cruise Control” is shown on the instrument panel display); To change the operating mode, use the button on the steering wheel (see that described on the following pages).

## ADAPTIVE CRUISE CONTROL ACTIVATION/DEACTIVATION Activation

To activate the device, press and release the button  fig. 235.

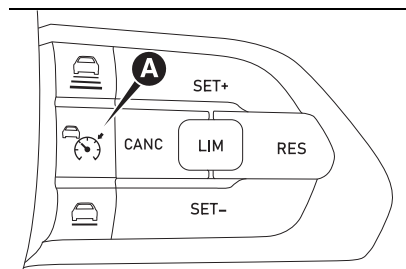

235

F1A0733

With the device activated and ready to work, the display shows a message indicating the "readiness" of the system and a dedicated icon as shown in fig. 236.



236

F1A0740

**WARNING** It is dangerous to leave the device activated when it is not used. There is a risk of inadvertently activating it and losing control of the vehicle due to unexpected excessive speed.

## Deactivation

With the device active, to deactivate it press and release the button .

## SETTING THE DESIRED SPEED

The device can be set only with speeds above 30 km/h (or 20 mph for markets with instrument panels giving mph) and with a maximum limit of 150 km/h (or 90 mph for markets with instrument panels giving mph).

The maximum speed value that can be set can be limited by Speed Limiters approved in certain countries or by the Speed Limiters set by fleets.

When vehicle reaches the desired speed, press and release the button SET + or SET - to set the speed to the current speed. The display will show the set speed. Then take your foot off the accelerator pedal.

Press the accelerator pedal to make the vehicle go faster than the set speed. While the accelerator pedal is pressed:

- ❑ a graphic on the display will make the Adaptive Cruise Control warning light flash if the target car ahead is not present. If the car in front is detected by the sensors, a graphic of the detected car will be displayed and flashing;

❑ the device will not be able to control the distance between the vehicle and the one ahead. In this case the speed will be determined only by the position of the accelerator pedal.

The device will return to normal operation as soon as the accelerator pedal is released.

The system cannot be set:

- ❑ when pressing the brake pedal;
- ❑ when the brakes are overheated;
- ❑ when the parking brake is engaged;
- ❑ when the gear lever is in the P (park), R (reverse) or N (neutral) positions (versions with automatic transmission or dual clutch automatic transmission);
- ❑ when the shift lever is in the R (reverse), neutral or in 1<sup>st</sup>(first gear engaged) positions (versions with manual transmission);
- ❑ when the clutch is pressed (versions with manual transmission);
- ❑ when the engine speed exceeds a maximum threshold (versions with manual transmission and versions with automatic transmission/dual-clutch automatic transmission) or goes below a minimum threshold (only versions with manual transmission);
- ❑ when the vehicle speed is not within the settable speed range;
- ❑ when an intervention of the ESC system (or ABS or other stability control

systems) is in progress, or has just ended;

- ❑ when the ESC system is off;
- ❑ during automatic braking by the Forward Collision Warning Plus system (where provided);
- ❑ when the Speed Limiter is active;
- ❑ in case of failure of the device;
- ❑ when the engine is off;
- ❑ in case of radar sensor obstruction: in this case, clean the sensor position in the zone shown in fig. 233. Use a clean cloth for cleaning. Do not use solvents or abrasive paste.

In case of system set, the conditions described above also cause a cancellation or deactivation of the system with times that may vary according to the conditions.

**WARNING** The device does not deactivate on reaching speeds higher than those that can be set (130 km/h or 81mph for instrument panel set to mph) with the accelerator pedal pressed. In these conditions, the device may not work correctly and it is advisable to deactivate it.

## **CHANGING THE SPEED**

### **Increasing speed**

After having set the device, the stored speed can be stored by holding the SET + button pressed.

❑ **Press the SET + button once:** the set speed will increase by 1 km/h (or by 1 mph when the measurement unit is set to mph). Each touch of the button once will increase the speed by 1 km/h (or by 1 mph, the latter for instrument panels set to miles per hour).

❑ **Hold the SET + button pressed:** the set speed will increase in 10 km/h steps (or in 5 mph steps when the measurement unit is set to mph) until the button is released. The set speed increase is shown on the display.

### **Decreasing speed**

After having set the device, the stored speed can be reduced by holding the SET – button pressed.

❑ **Press the SET – button once:** the set speed will be reduced by 1 km/h (or by 1 mph when the measurement unit is set to mph). Each subsequent press of the button will reduce the speed by 1 km/h (or by 1 mph when the measurement unit is set to mph).

❑ **Hold the SET – button pressed:** the set speed will decrease in 10 km/h steps (or in 5 mph steps when the measurement unit is set to mph) until the button is released. The set speed decrease is shown on the display.

### **WARNINGS**

By keeping the accelerator pedal depressed, the vehicle can continue to accelerate beyond the set speed. In

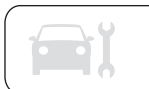



this case, press the SET + (or SET –) button to set the speed to the current speed of the car.

When the SET – button is pressed to reduce the speed, the braking system intervenes automatically if the exhaust brake does not slow the car down sufficiently to reach the set speed.

The device holds the set speed uphill and downhill; however a slight variation is entirely normal, particularly on slight gradients.

For versions with manual transmission, gears can be shifted during operation of the device to allow to select the gear suited to the set speed and keep the device set. The device is cancelled when you press and hold the clutch pedal down or putting the gear lever in the neutral position for more than a certain time limit.

The automatic transmission (or dual clutch automatic transmission) could change to a lower gear when driving downhill or when accelerating. This is normal and necessary to maintain the set speed.

The device is switched off while driving if the brakes overheat.

### **SPEED VARIATION WITH ROAD SIGN (Intelligent Adaptive Cruise Control)**

The system can be used to set a speed limit equal to that indicated on the road sign detected by the “Traffic Sign Recognition” system when the navigator is present (see the respective paragraph in this section).

If the setting was selected, the “Traffic Sign Information” system will suggest the new speed limit, which will be shown with a message on the instrument panel display. The driver can confirm the speed setting RES suggested by the road sign with the RES button.

### **ACCELERATING WHEN OVERTAKING**

When driving with the device active and following a vehicle, the device provides additional acceleration to facilitate overtaking, when travelling over a given speed and switches on the left direction indicator on roads with right-hand traffic (of the right indicator for roads with left-hand traffic).

The device detects the direction of traffic automatically when vehicle passes from left-hand traffic to right-hand traffic.

### **RECALLING THE SPEED**

Once the system has been cancelled but not deactivated, if a speed was previously set simply press the RES button and remove your foot from the accelerator to recall it.

The system will be set to the last stored speed.

Before returning to the previously set speed, bring the speed close to that value, then press the RES button and release it.

**WARNING** The recall function must only be used if the road and traffic conditions so allow. Recalling an excessively high or low speed for the current traffic and road conditions could cause an acceleration or a deceleration of the vehicle. Failure to comply with these precautions may cause serious accidents and fatal injuries.

### **SETTING THE DISTANCE BETWEEN CARS**

The distance between your vehicle and the vehicle ahead may be set to 1 bar (short), 2 bars (medium), 3 bars (long), 4 bars (maximum) fig. 237.





237

F1A0738

The distances from the vehicle ahead are proportional to speed.

The interval of time with respect to the vehicle ahead remains constant and varies from 1 second (for the short distance 1-bar setting) to 2 seconds (for the maximum distance 4-bar setting).

The set distance is shown on the display by means of a dedicated icon (or in the “Driver Assist” area).

The setting is 4 (maximum) the first time the device is used. After the distance has been modified by the

driver, the new distance will be stored also after the system is deactivated and reactivated.

### To decrease the distance

Press and release the button to decrease the distance setting .

The distance setting decreases by one bar (shorter) every time the button is pressed.

The set speed is held if there are no cars ahead. Once the shortest distance has been reached, a further press of the button will set the longest distance. If a vehicle is detected ahead in the same lane, travelling at slower speed, an icon appears on the display (where provided). The device will automatically adjust the vehicle speed to hold the distance setting regardless of the set speed.

The vehicle holds the set distance until:

- the vehicle ahead accelerates to a speed higher than the set speed;
- the vehicle ahead leaves the lane or the detection field of the Adaptive Cruise Control device sensor;
- the distance setting is changed;
- the Adaptive Cruise Control device is deactivated/cancelled.

**WARNING** The maximum braking applied by the device is limited. The

driver may apply the brakes in all cases if needed.

**WARNING** If the device predicts that the braking level is not sufficient to hold the set distance, the warning message “BRAKE!” will blink on the display to notify the driver while approaching the vehicle ahead. An acoustic warning is also emitted. In this case, it is advisable to brake immediately as necessary to hold a safe distance from the vehicle ahead.

**WARNING** The driver is responsible for ensuring that there are no pedestrians, other vehicles or objectives along the direction of the vehicle. Failure to comply with these precautions may cause serious accidents and injuries.

**WARNING** The driver is fully responsible for holding a safe distance from the vehicle ahead respecting the highway code in force in the respective country.

### DEACTIVATION

The device is deactivated and the set speed is cancelled if:

- the Adaptive Cruise Control button  is pressed;



- ❑ the Speed Limiter button is pressed;
  - ❑ the ignition device is set to STOP.
- The device is cancelled (the set speed and distance are stored):
- ❑ when the CANC button is pressed;
  - ❑ when the conditions indicated in the paragraph "Setting the desired speed" occur;
  - ❑ when the vehicle speed drops under the minimum set speed (e.g. in presence of slow vehicles).

If these conditions occur while the system is decelerating with respect to a vehicle ahead, the system could continue the deceleration, if necessary, also after it is cancelled or deactivated within the minimum speed settable on the system.

### **SYSTEM LIMITED OPERATION WARNING**

If the dedicated message is shown on the display, a condition limiting the system operation may have occurred. The possible reasons of this limitation are a fault, blinding of one of the sensors or something blocking the camera view.

In case of radar sensor obstruction, clean the sensor position in the zone shown in fig. 232.

Use a clean cloth for cleaning. Do not use solvents or abrasive paste.

When the conditions limiting the system functions end, this will go back to normal and complete operation. Should the fault persist, contact a Fiat Dealership.

### **PRECAUTIONS WHILE DRIVING**

The device may not work correctly in some driving conditions (see below): the driver must control the vehicle at all times.

#### **Towing a trailer**

Use of the device is not recommended while towing a trailer.

#### **Vehicle not aligned**

The device may not detect a vehicle travelling on the same lane but which is not aligned along the same direction of travel or a vehicle which is cutting in from a side lane. Sufficient distance from the vehicles ahead may not be guaranteed in these cases.

The non-aligned vehicle can weave in and out of the driving direction causing the vehicle to brake or accelerate unexpectedly.

#### **Steering and curves**

On curves fig. 238 with the device set, it could limit speed and acceleration to vehicle stability even if no cars are detected ahead.

When leaving the curve, the device resets the previously set speed.

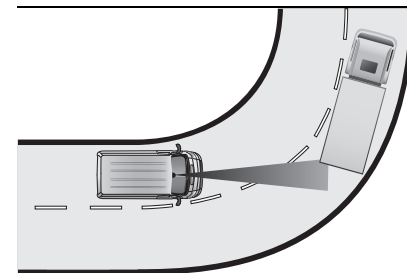

238

F1A0997

**WARNING** In case of narrow curves, the performance of the device could be limited. In this case, it is advisable to deactivate the device. In this case, it is advisable to deactivate the device.

#### **Using the device on gradient**

When driving on roads with variable gradient, the device may not detect the presence of a vehicle on the lane. Device performance could be limited according to speed, load, traffic conditions and gradient steepness.

#### **Lane change**

The device may not detect the presence of a vehicle until it is fully in your lane fig. 239.

In this case, sufficient distance from the vehicle which is changing lane may not be guaranteed: it is advisable to pay

the utmost attention at all times and be always ready to press the brakes if needed.

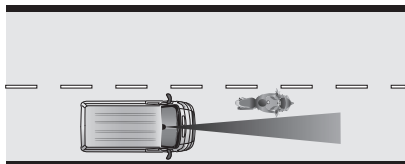

239

F1A0996

### Small vehicles

Some narrow vehicles (e.g. bicycles and motorcycles fig. 240) travelling near the outer edges of the lane or which enter the lane from kerbside are not detected until they are fully in the lane.

Sufficient distance from the vehicles ahead may not be guaranteed in these cases.

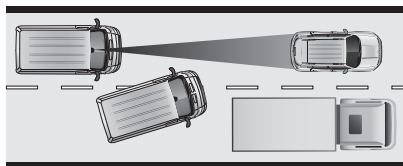

240

F1A0995

### Stationary objects and vehicles

The device cannot detect the presence of stationary vehicles or objects. For example, the device will not operate if the vehicle ahead leaves the lane and a vehicle ahead of that one is standing on the lane. Pay the utmost attention at all times and be always ready to press the brakes if needed.

### Objects and vehicles moving in opposite or crosswise direction

The device cannot detect the presence of objects or cars travelling in opposite or crosswise direction fig. 241 and consequently will not be operated.

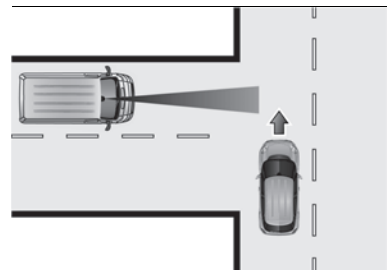

241

F1A0731



### IMPORTANT

**154)** Pay the utmost attention while driving at all times and be always ready to press the brakes if needed.

**155)** The system is an aid for the driver, who must always pay full attention while driving. The responsibility always rests with the driver, who must take into account the traffic conditions in order to drive in complete safety. The driver must always maintain a safe distance from the vehicle in front.

**156)** The device is not activated in presence of pedestrians, oncoming vehicles in the opposite direction of travel or moving in the crosswise direction and stationary objects (e.g. a vehicle standing in a queue or a broken down vehicle).

**157)** The device cannot take account of road, traffic and weather conditions and conditions of poor visibility (e.g. fog).

**158)** The device does not always fully recognise complicated driving conditions which could cause incorrect or non-



existing determination of the safe distance to be held.

**159)** The device cannot apply the maximum braking force: the car will not be stopped completely.

**160)** The radar is provided with defrosting system. For this reason, it can reach high temperatures in some conditions. If you need to operate in the zone surrounding the sensor, wait for at least 30 seconds from when the engine is switched off.



### WARNING

**55)** The system may have limited operation or not work at all in weather conditions such as: heavy rain, hail, thick fog, heavy snow.

**56)** The section of the bumper area in front the sensor or the radar sensor itself must not be covered with stickers, auxiliary headlights or any other object.

**57)** Operation can be adversely affected by any structural change made to the car, such as a modification to the front geometry, tyre change, or a heavier load than the standard load of the car.

**58)** Incorrect repairs made on the front part of the vehicle (e.g. bumper, chassis) may alter the position of the radar sensor, and adversely affect its operation. Go to a Fiat Dealership for any operation of this type.

**59)** Do not tamper with or carry out any intervention on the radar sensor or on the camera on the windscreen glass. In the event of a sensor failure, contact a Fiat Dealership.

**60)** Do not wash with high-pressure jets in the bumper lower area: in particular do not operate on the system's electrical connector. Do not use solvents or abrasive paste.

**61)** Be careful in case of repairs and painting in the zone around the sensor. In the event of a frontal impact the sensor may automatically deactivate and display a warning to indicate that the sensor needs to be repaired. Even without a malfunction warning, deactivate the system operation if you think that the position of the radar sensor has changed (e.g. due to low-speed frontal impact as during parking manoeuvres). In these cases, go to a Fiat Dealership to have the radar sensor realigned or replaced.

## CO-DRIVER SYSTEM WITH STOP&GO - Adaptive Cruise Control with Stop&Go

(where provided)

**161) 162) 156) 157) 158) 166)**

**62) 63) 57) 65) 66) 60) 68)**

### DESCRIPTION

The Adaptive Cruise Control with Stop&Go is a driver assistance device which combines the Cruise Control functions with one for controlling the distance from the vehicle ahead.

The system allows the vehicle to be held at the desired speed without needing to press the accelerator. It also allows holding the distance set by the driver from the vehicle ahead.

The system uses a radar sensor, located behind the front bumper and a camera, located in the middle area of the windscreen fig. 242, to detect the presence of a vehicle close ahead.

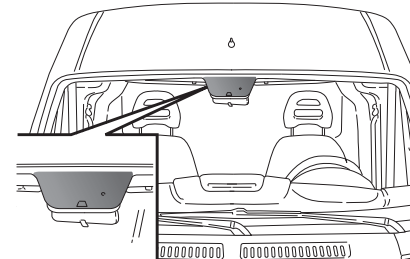

242

F1A0988

### WARNINGS

If the sensor does not detect any vehicle ahead, the device will maintain a fixed set speed.

If the sensor detects a vehicle ahead, the device automatically intervenes by braking (or accelerating) slightly in order not to exceed the original set speed, so that the vehicle keeps the preset distance, seeking to adapt to the speed of the vehicle ahead.

It is advisable to turn the device off in the following cases:

- driving in fog, heavy rain, snow;
- driving close to a bend (winding roads), icy, snowy, slippery roads or with a steep uphill or downhill slope;
- entering a turn lane or an off-ramp of the motorway;
- towing a trailer;
- when circumstances do not allow safe driving at a constant speed.

## ACTIVATION / DEACTIVATION

### Activation

To activate the device, press and release the button (A) fig. 243.

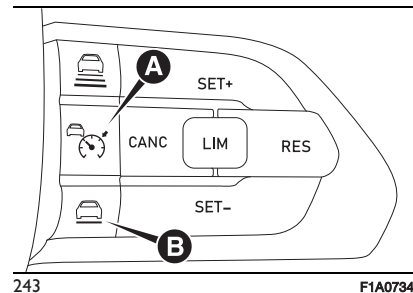

With the system enabled and ready for operation, the display shows a graphic indicating the "readiness" of the system (A) fig. 244.

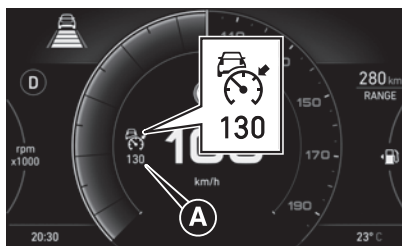

244

F1A0739

**WARNING** It is dangerous to leave the device activated when it is not used. There is a risk of inadvertently activating it and losing control of the vehicle due to unexpected excessive speed.

### Deactivation

With the device active, to deactivate it press and release the button (A) fig. 243.

## SETTING THE DESIRED SPEED

The device can only be set with the speed over 0 km/h (0 mph) and under 130 km/h (81 mph).

When vehicle reaches the desired speed, press and release the button SET + or SET - to set the speed to the current speed. The display will show the set speed. Then take your foot off the accelerator pedal. Press the

accelerator pedal to make the vehicle go faster than the set speed. While the accelerator pedal is pressed:

- a dedicated message will appear on the display for a few seconds;
- the device will not be able to control the distance between the vehicle and the one ahead. In this case the speed will be determined only by the position of the accelerator pedal.

The device will return to normal operation as soon as the accelerator pedal is released.

The system cannot be set:

- when pressing the brake pedal;
- when the brakes are overheated;
- when the electric parking brake is engaged;
- when the transmission in P (Park), R (Reverse) or N (Neutral);
- when the engine speed is above a maximum threshold;
- when an intervention of the ESC system (or ABS or other stability control systems) is in progress, or has just ended;
- when the Autonomous Emergency Brake Control (AEB Control) system (where provided) is braking automatically;
- when the Speed Limiter is active: press the button (A) fig. 243 to deactivate the Speed Limiter. Press the



(A) button again to set the system to "ready" status;

- ❑ in case of failure of the device;
- ❑ when the engine is off;
- ❑ on very steep slopes;
- ❑ in case of radar sensor obstruction: in this case, clean the sensor. Use a clean cloth for cleaning. Do not use solvents or abrasive paste. In case of system set, the conditions described above also cause a cancellation or deactivation of the system with times that may vary according to the conditions.

**WARNING** The device is not deactivated when speeds higher than those set are reached with the accelerator pedal pressed. In these conditions, the device may not work correctly and it is advisable to deactivate it.

### **INCREASING/DECREASING OF SPEED**

After having set the system, the stored speed can be increased or decreased by holding the SET + and SET - buttons pressed.

- ❑ **Press the SET + or SET - button once:** the set speed will increase or decrease by 1 km/h (1 mph). Each subsequent press of the button will

result in an increase or decrease of 1 km/h (1 mph).

- ❑ **Hold the SET + or SET - button pressed:** the set speed will increase or decrease in 10 km/h steps (or 5 mph) until the button is released.

The set speed increase or decrease is shown on the display.

### **WARNINGS**

- ❑ By keeping the accelerator pedal depressed, the vehicle can continue to accelerate beyond the set speed. In this case, press the SET + (or SET -) button to set the speed to the current speed of the vehicle.
- ❑ When the SET - button is pressed to reduce the speed, the braking system intervenes automatically if the exhaust brake does not slow the vehicle down sufficiently to reach the set speed.
- ❑ The system holds the set speed uphill and downhill; however a slight variation is entirely normal, particularly on steep gradients.
- ❑ The device is switched off while driving if the brakes overheat.

### **Speed variation with road sign (Intelligent Adaptive Cruise Control)**

The system can be used to set a speed limit equal to that indicated on the road sign detected by the "Traffic Sign Recognition" system when the

navigator is present (see the respective chapter in this section).

The "Traffic Sign Recognition" system will suggest the new speed limit which will be shown with a message. The driver can confirm the speed setting suggested by the road sign with the RES button.

### **Coming to a stop and restarting**

The system can decelerate the vehicle to a standstill when the vehicle in front of it slows down and stops. The system will automatically restart the vehicle if the vehicle comes to a stop and the vehicle in front restarts within two seconds. If the vehicle in front restarts after 2 seconds, the RES button or the accelerator pedal must be pressed to reactivate the system and restart. If the system keeps the vehicle at a standstill for three minutes, the electric parking brake will activate and the system will be deactivated.

**NOTE** When the system is keeping the vehicle stopped, the electric parking brake will be activated and the system will be deactivated at speeds close to stopping, if the driver unbuckles the seat belt or opens the door.

**WARNING** The driver must ensure that there are no pedestrians, vehicles or

other obstacles in front of the vehicle when the system is reactivated. Failure to comply with this precaution may cause serious accidents and fatal injuries.

## ACCELERATING WHEN OVERTAKING

When driving with the device active and following a vehicle, the device provides additional acceleration to facilitate overtaking, when travelling over a given speed and switches on the left direction indicator on roads with right-hand traffic (of the right indicator for roads with left-hand traffic). The device detects the direction of traffic automatically when the car passes from left-hand traffic to right-hand traffic.

## RECALLING THE SPEED

Once the system has been cancelled but not deactivated, if a speed was previously set simply press the RES button and remove your foot from the accelerator to recall it.

The system will be set to the last stored speed.

Before returning to the previously set speed, bring the speed close to that value, then press the RES button and release it.

**WARNING** The recall function must only be used if the road and traffic conditions so allow. Recalling an excessively high or low speed for the current traffic and road conditions could cause an acceleration or a deceleration of the vehicle. Failure to comply with these precautions may cause serious accidents and fatal injuries.

## SETTING THE DISTANCE BETWEEN VEHICLES

The distance between your vehicle and the vehicle ahead may be set to 1 bar (short), 2 bars (medium), 3 bars (long), 4 bars (maximum) fig. 245.



245

F1A0738

The distances from the vehicle ahead are proportional to speed. The interval of time with respect to the vehicle ahead remains constant and varies from 1 second (for the short distance 1-bar setting) to 2 seconds (for the maximum distance 4-bar setting). The set distance is shown on the display by means of a dedicated icon (A) fig. 246 (or in the “Driver Assist” area).

The setting is 4 (maximum) the first time the device is used. After the distance has been modified by the





driver, the new distance will be stored also after the system is deactivated and reactivated.



246

F1A0740

### To decrease the distance

Press and release the button to decrease the distance setting (B) fig. 243.

The distance setting decreases by one bar (shorter) every time the button is pressed.

The set speed is held if there are no cars ahead. Once the shortest distance has been reached, a further press of the button will set the longest distance. If a vehicle shown on the instrument panel proceeds in the same lane, travelling at slower speed, an icon appears on the display (where provided). The device will automatically adjust the vehicle speed to hold the distance setting regardless of the set speed.

The vehicle holds the set distance until:

- ❑ the vehicle ahead accelerates to a speed higher than the set speed;
- ❑ the vehicle ahead leaves the lane or the detection field of the Adaptive Cruise Control device sensor;
- ❑ the distance setting is changed;
- ❑ the Adaptive Cruise Control device is deactivated/cancelled.

WARNING The maximum braking applied by the device is limited. The driver may apply the brakes in all cases if needed.

WARNING If the system predicts that the braking level is insufficient to maintain the set distance, it signals the driver to pay attention when approaching the vehicle ahead by displaying an alert message on the display. An acoustic warning is also emitted. In this case, it is advisable to brake immediately as necessary to hold a safe distance from the vehicle ahead.

WARNING The driver is responsible for ensuring that there are no pedestrians, other vehicles or objectives along the direction of the vehicle. Failure to comply with these precautions may cause serious accidents and injuries.

WARNING The driver is fully responsible for holding a safe distance from the vehicle ahead respecting the highway code in force in the respective country.

### DEACTIVATION

The device is deactivated and the set speed is cancelled if:

- ❑ the (A) fig. 243 button is pressed on the Adaptive Cruise Control;
- ❑ the Speed Limiter button is pressed;
- ❑ the ignition device switch is in the STOP position;

The device is cancelled (the set speed and distance are stored):

- ❑ when the CANC button is pressed;
- ❑ when the conditions shown in the “Setting the desired speed” paragraph occur.

If these conditions occur while the system is decelerating with respect to a vehicle ahead, the system could continue the deceleration, if necessary, also after it is cancelled or deactivated within the minimum speed settable on the system.

### MINIMUM RISK MANOEUVRE

If you remove your hands from the steering wheel, a countdown will begin which will result in the activation of visual and audible alerts (see the



description provided in the "Co-Driver with Stop&Go - Traffic Jam Assist" chapter in this section). Furthermore, the system will initiate a minimum risk manoeuvre to bring the vehicle to safety if no hands are detected.

The Adaptive Cruise Control system will braking slightly 23 seconds after your hands have been removed from the steering wheel to warn you and encourage you to regain control of the vehicle.

If the driver does not regain control of the vehicle after a further 3 seconds, the system will brake again lightly. Subsequently, the system will automatically braking to bring the vehicle to a stop if you still do not put your hands back on the steering wheel persists.

The hazard warning lights will be activated as soon as the system activates the automatic braking. When the vehicle is at a standstill, the system will unlock the doors (if previously locked) and keep the hazard lights on. If you regain control of the vehicle during the minimum risk manoeuvre, placing your hands on the steering wheel or pressing the accelerator pedal will cause the system to behave normally and the minimum risk manoeuvre will be aborted.

## SYSTEM LIMITED OPERATION WARNING

If the dedicated message is shown on the display, a condition limiting the system operation may have occurred.

The possible reasons of this limitation are something blocking the camera view or a fault.

In case of camera blinding (e.g. caused by low sun in front of the windscreen), wait until the light and glare conditions cease and allow the system to operate fully.

If an obstruction is signalled, clean the area of the windscreen indicated in fig. 242 and check that the message has disappeared.

When the conditions limiting the system functions end, this will go back to normal and complete operation. Should the fault persist, contact a Fiat Dealership.

## PRECAUTIONS WHILE DRIVING

The system may not work correctly in some driving conditions (see below): the driver must control the vehicle at all times.

### Vehicle not aligned

The system may not detect a vehicle travelling on the same lane but which is not aligned along the same direction of travel or a vehicle which is cutting

in from a side lane. Sufficient distance from the vehicles ahead may not be guaranteed in these cases.

The non-aligned vehicle can weave in and out of the driving direction causing the vehicle to brake or accelerate unexpectedly.

### Steering and curves

On bends fig. 247 with the system set, it could limit speed and acceleration to vehicle stability even if no vehicles are detected ahead.

When leaving the bend, the system resets the previously set speed.

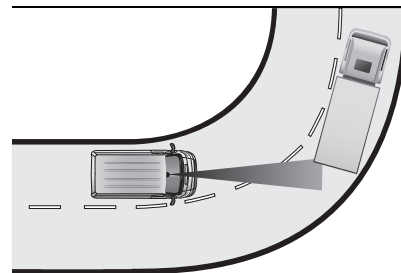

247

F1A0997

**WARNING** In case of narrow bends, the performance of the system could be limited. In this case, it is advisable to deactivate the device.

### Using the system on gradient

When driving on roads with variable gradient, the system may not detect



the presence of a vehicle on the lane. The system performance be limited according to speed, load of the vehicle, traffic conditions and gradient steepness.

### Lane change

The system may not detect the presence of a vehicle until it is fully in your lane fig. 248.

In this case, sufficient distance from the vehicle which is changing lane may not be guaranteed: it is advisable to pay the utmost attention at all times and be always ready to press the brakes if needed.

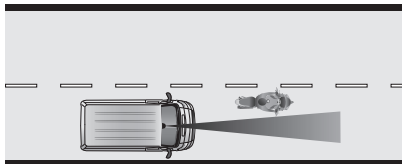

248

F1A0996

### Small vehicles

Some narrow vehicles (e.g. bicycles and motorcycles fig. 249) travelling near the outer edges of the lane or which enter the lane from kerbside are not detected until they are fully in the lane.

Sufficient distance from the vehicles ahead may not be guaranteed in these cases.

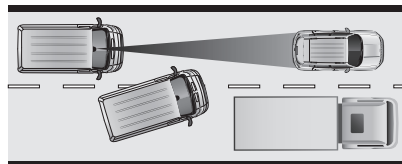

249

F1A0995

### Stationary objects and vehicles

The system cannot detect the presence of stationary objects and vehicles if you are travelling at a speed exceeding 60 km/h (37 mph). For example, the system may not operate if the vehicle ahead leaves the lane and a car stopped on the lane ahead of it. Pay the utmost attention at all times and be always ready to press the brakes if needed.

### Objects and vehicles moving in opposite or crosswise direction

The system cannot detect the presence of objects or cars travelling in opposite or crosswise direction fig. 250 and consequently will not be operated.

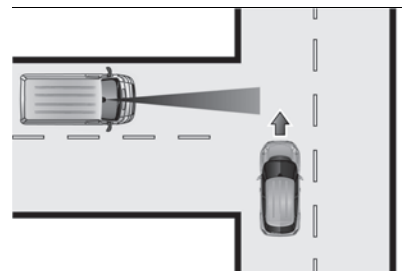

250

F1A0781



### IMPORTANT

**161)** Pay the utmost attention while driving at all times and be always ready to press the brakes if needed.

**162)** The system is an aid for the driver, who must always pay full attention while driving. The responsibility always rests with the driver, who must take into account the traffic conditions in order to drive in complete safety. The driver must always maintain a safe distance from the vehicle in front.

**163)** The device is not activated in presence of pedestrians, oncoming vehicles in the opposite direction of travel or moving in the crosswise direction and stationary objects (e.g. a vehicle standing in a queue or a broken down vehicle).

**164)** The device cannot take account of road, traffic and weather conditions and conditions of poor visibility (e.g. fog).

**165)** The device does not always fully recognise complicated driving conditions which could cause incorrect or non-

existing determination of the safe distance to be held.

**166)** The device can take the car to a standstill but the driver must always be ready to apply the brakes, if necessary.



## WARNING

**62)** The system may have limited operation or not work at all in weather conditions such as: heavy rain, hail, low sun, blinded camera, thick fog, heavy snow.

**63)** The camera on the windscreen must not be covered with stickers or any other object.

**64)** Operation can be adversely affected by any structural change made to the car, such as a modification to the front geometry, tyre change, or a heavier load than the standard load of the car.

**65)** Incorrect repairs in the zone where the camera is mounted may interfere with its field of vision and reduce its performance (e.g. application of fillers or glues to remove scratches). Go to a Fiat Dealership for any operation of this type.

**66)** Do not tamper with nor operate on the camera on the windscreen. In the case of damage, contact a Fiat Dealership.

**67)** Do not wash with high-pressure jets in the bumper lower area: in particular do not operate on the system's electrical connector. Do not use solvents or abrasive paste.

**68)** Be careful in case of repairs and painting in the zone around the sensor. In the event of a frontal impact the sensor may automatically deactivate and display a warning to indicate that the sensor needs

to be repaired. Even without a malfunction warning, deactivate the system operation if you think that the position of the radar sensor has changed (e.g. due to low-speed frontal impact as during parking manoeuvres). In these cases, go to a Fiat Dealership to have the radar sensor realigned or replaced.

## CO-DRIVER SYSTEM WITH STOP&GO - Traffic Jam Assist

(where provided)

The system combines Active Cruise Control (ACC) functions and lane centring logic to control the trajectory of the vehicle holding it as close as possible in the middle of the lane and also managing speed.

 **167) 168) 169) 170) 171) 172) 173) 174) 175)**

It is a driving assistance system that can be activated on all road types.

The system uses information from the front camera and radar to help you keep the vehicle in the middle of the lane at a constant speed.

If the event that the lane marking line is missing or not correctly recognised, the Co-Driver system may also use information from adjacent and preceding vehicles. This condition may occur in congested traffic, when the vehicle front and/or objects around the vehicle obstruct the lane markings. In

this case, the system can use the queues of cars in the traffic to define the driving trajectory. Alternatively, the system can use the "lock-on" strategy, which allows it to automatically follow the car in front.

## OPERATION

The system only works if the driver keeps his or her hands on the steering wheel.

If the system detects that hands have been removed from the steering wheel, it will alert you of the need to put your hands back on the steering wheel (see following pages).

**WARNING** The Co-Driver system can take a few seconds to activate once all conditions are met. During this time, a grey indication will appear on the instrument panel display and the system will be activated automatically as soon as all conditions are met, without any intervention by the driver.



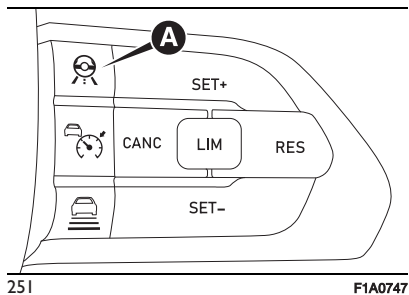

The following conditions must be met before the Co-Driver system turns on:

- ❑ the Co-Driver system must be switched on by pressing the button (A) fig. 251 on the steering wheel;
- ❑ the Adaptive Cruise Control device (ACC) must be on;
- ❑ the vehicle speed must be between 0 and 150 km/h;
- ❑ no anomaly related to the camera or the radar must be present;
- ❑ the road lane width must be between 2.7 metres and 4.2 metres;
- ❑ the direction indicators must not be activated;
- ❑ no anomaly related to the system must be present.

### ACTIVATION / DEACTIVATION

To activate the system, press button (A) fig. 251 on the steering wheel.

To deactivate the system press the button again.

### Suspension conditions

System operation is temporarily paused in the following cases:

- ❑ ACC system deactivation or inhibition (see paragraph the Adaptive Cruise Control function);
- ❑ if there are very tight bends;
- ❑ one of the two lines is broken or ruined;
- ❑ the sun is low and is dazzling the camera on the windscreen;
- ❑ if the left or right direction indicator is activated;
- ❑ if the driver intentionally changes lanes without switching on the direction indicator on the corresponding side;
- ❑ when there is no surrounding traffic and there are no horizontal markings or they cannot be detected;
- ❑ if there are system anomalies;
- ❑ if vehicle speed exceeds the maximum limit;
- ❑ if lateral acceleration is high;
- ❑ poor visibility (due to heavy rain, snow, fog, etc.);

### Automatic deactivation

The system is deactivated if you take your hands off the steering wheel for 45 seconds.

**WARNING** When the Co-Driver is paused the related graphics in the dedicated area will turn grey.

**WARNING** Hands on the steering wheel are detected by a capacitive sensor installed in it.

When the suspension conditions are over, the Co-Driver will be available again without requiring any reactivation action by the driver.

### INDICATIONS ON THE DISPLAY

The system status can always be viewed through a dedicated area on the instrument panel display.

The system status is indicated by the colour of the  symbol.

If the driver's hands are not on the steering wheel, a series of warnings will appear on the instrument panel display to alert the driver that he needs to reposition his hands on the steering wheel. Acoustic signals will also be emitted.

After a certain period of time, the Co-Driver system will be disabled if the driver has not repositioned his or her hands on the steering wheel.

When the system does not detect hands on the steering wheel for a few seconds, it will warn the driver by

displaying a dedicated screen at the centre of the instrument panel display (see the description in the following pages).

## SYSTEM STATUS

### Active system

The active and correctly operating system status is indicated by the following screen on the instrument panel display fig. 252 in the "Driver Assistance" menu.



252

F1A0744

When the hands are removed from the steering wheel, the system does not deactivate automatically, but after a few seconds: some dedicated screens appear on the instrument panel display in sequence, to warn the driver to return his or her hands to the steering wheel (see the description below).

### Active system (hands removed from the steering wheel for a short time)

As soon as you remove your from the steering wheel, this screen fig. 253 appears on the instrument panel display: in this case, the system remains active.



253

F1A0776

If the driver has not returned his or her hands to the steering wheel within a few seconds, this screen fig. 254 will appear on the instrument panel display.



254

F1A0777

### Active system (hands removed from the steering wheel for a long time)

If the driver has not yet returned his or her hands to the steering wheel, this screen fig. 255 will appear on the instrument panel display.

An acoustic warning will sound also in this case. If you do not put your hands back on the steering wheel after an extended period of time, a deactivation message will appear on the instrument panel. The steering wheel control will then be deactivated.



255

F1A0778

When the Co-Driver system is active, Lane Control (where provided) is temporarily paused. When the Co-Driver system is not active, Lane Control (where provided), if previously activated, is still available. For more information on the Lane Control system, see the "Driving assistance



systems" chapter in the "Safety" section.

### SYSTEM LIMITED OPERATION

The Co-Driver may have limited or reduced functionality when one of the following conditions occurs:

The main ones are listed below:

- ❑ lane marking lines are not clear or in conditions of poor visibility (e.g. in heavy rain, snow, fog, etc.);
- ❑ either the camera or radar are damaged, covered or obstructed (e.g. by mud, ice, snow, etc.);
- ❑ when driving in the hills or on roads with narrow turns;
- ❑ near motorway toll-gates;
- ❑ when the motorway entrance or exit is more than 6 meters wide;
- ❑ if the camera is exposed to dazzling light (e.g. reflection or direct sunlight).



#### IMPORTANT

**167)** Many unpredictable situations can arise, affecting the performance of Co-Driver system. The driver must be ready to react immediately and take control of the vehicle in place of Co-Driver system.

**168)** If the vehicle approaches a bend that is too tight with respect to the current speed, the Co-Driver system turns off. The driver must therefore be ready to immediately regain control of the vehicle

at any time. To avoid this situation it is important that the vehicle speed set does not exceed the current road speed limit.

**169)** The Co-Driver system uses a hands on steering wheel detection sensor: the driver must keep his hands on the steering wheel at all times. If the hands are removed from the steering wheel for a certain period of time, the system disengages.

**170)** When using Co-Driver system, hold the steering wheel and consider the road conditions and surrounding traffic. The driver must therefore be ready to immediately regain control of the vehicle at any time. Failure to observe these instructions can cause severe injuries with even lethal consequences.

**171)** The Co-Driver system is an aid for the driver, who must always pay full attention while driving. The responsibility always rests with the driver, who must take into account the traffic conditions in order to drive in complete safety. The driver must always maintain a safe distance from the vehicle in front.

**172)** If the windscreen must be replaced due to scratches, chipping or breakage, contact exclusively a Fiat Dealership. Do not replace the windscreen on your own, risk of malfunction! It is advisable to replace the windscreen if it is damaged in the area of the camera.

**173)** Driving the vehicle on urban routes could significantly change the sensitivity of the system, due to the limited and/or lack of vertical and horizontal signs and variable traffic conditions.

**174)** Do not place any objects on the steering wheel (e.g. steering wheel covers of any type or material) which could

interfere with the capacitive hand detection sensor on the steering wheel.

**175)** External factors and conditions may affect the proper operation of the Co-Driver system: damage or obstructions caused by mud, ice, snow, etc., damaged or misaligned bumpers, interference with other equipment that causes electromagnetic waves.

## SAVING FUEL

Some useful tips are given below for fuel saving and reducing harmful emissions of CO<sub>2</sub> and other pollutants (nitrogen oxides, unburnt hydrocarbons, Particulate Matter (PM), etc.).

### GENERAL INFORMATION

The general factors that affect fuel consumption are listed below.

#### Vehicle maintenance

Have checks and adjustments carried out in accordance with the "Scheduled Servicing Plan".

#### Tyres

Check the tyre pressures at least once every four weeks: if the pressure is too low, consumption levels increase as resistance to rolling is higher.

#### Unnecessary loads

Do not travel with an overloaded boot. The weight of the vehicle (especially



when driving in town) and its geometry greatly affect fuel consumption and stability.

### Roof rack/ski rack

Remove the roof rack or the ski rack from the roof after use. These accessories reduce the aerodynamic coefficient of the vehicle and have a negative effect on fuel consumption. When transporting particularly large objects, use a trailer if possible.

### Electric devices

Use electrical devices only for the amount of time needed. The heated rear window, additional headlights, windscreen/rear window wipers and heater fan need a considerable amount of energy, therefore increasing fuel consumption (by up to 25% in the urban cycle).

### Climate control module

Air conditioning leads to higher fuel consumption (on average up to +20%). If the temperature outside permits, try and use the ventilation only.

### Devices for aerodynamic control

The use of non-certified spoilers may adversely affect air drag and fuel consumption.

## DRIVING STYLE

The main driving styles that affect fuel consumption are listed below.

### Start

Do not warm up the engine at low or high revs when the vehicle is stationary; this causes the engine to warm up more slowly, thereby increasing fuel consumption and emissions. It is therefore advisable to move off immediately, slowly, avoiding high speeds: in this way the engine will warm up more quickly.

### Unnecessary actions

Avoid accelerating when stopped at traffic lights or before switching off the engine.

This action and also double declutching is absolutely pointless on modern cars and also increases consumption and pollution.

### Gear selection

As soon as the conditions of the traffic and road permit, use a higher gear. Using a low gear for faster acceleration will increase fuel consumption.

In the same way improper use of a high gear increases consumption, emissions and engine wear.

### Top speed

Fuel consumption increases considerably with speed.

Maintain a constant speed, avoiding unnecessary braking and acceleration, which cost in terms of both fuel consumption and emissions.

### Acceleration

Accelerating violently will greatly affect consumption and emissions: acceleration should be gradual.

## USAGE CONDITIONS

The main usage conditions that negatively affect fuel consumption are listed below.

### Cold starting

Short journeys and frequent cold starts do not allow the engine to reach optimum operating temperature. Consequently, both consumption (from +15 to +30% on the urban cycle) and emissions will increase.

### Traffic and road conditions

Rather high consumption levels are linked to situations with heavy traffic, for instance when travelling in queues with frequent use of the lower gears or in cities with many traffic lights. Winding mountain roads and rough road surfaces also adversely affect consumption.

### Stops in traffic

During prolonged hold-ups (e.g. level crossings) the engine should be switched off.



## REFUELLING THE VEHICLE

### IN BRIEF

*Stop the engine before refuelling.*

Only refuel with automotive diesel conforming to the European specification EN590.

### OPERATION AT LOW TEMPERATURES

If the outside temperature is very low, diesel thickens due to the formation of paraffin clots with consequent defective operation of the fuel supply system.

In order to avoid these problems, different types of diesel are distributed according to the season: summer type, winter type and arctic type (cold/mountain areas). If refuelling with diesel whose specifications are not suitable for the usage temperature, it is advisable to mix PETRONAS DURANCE DIESEL ART additive in the proportions shown on the container with the fuel. Pour the additive into the tank before the fuel.

When using or parking the vehicle for a long time in the mountains or cold areas, it is advisable to refuel using locally available diesel fuel. In this case,

it is also advisable to keep the tank over 50% full.



### REFUELLING CAPACITY

To ensure that you fill the tank completely, top up twice after the first click of the fuel supply gun. Further top-ups could cause faults in the fuel feeding system.

### FUEL TANK CAP

When refuelling, open flap (A) fig. 256 located on the left side of the vehicle therefore unscrew the cap (B) fig. 256 turning it counter-clockwise.

For versions / markets where provided, insert the ignition key in the lock of the cap. Turn the key counter-clockwise and remove the cap by gripping the key. Do not remove the key from the cap during refuelling. During the operation of refuelling, the cap can be hung to its appropriate place located on the door A (A) (fig. 256).

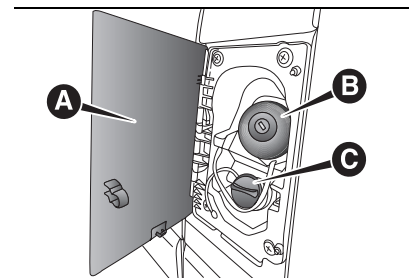

256

F1A0765

The sealing may cause a slight pressure increase in the tank. A little breathing off, while slackening the cap is absolutely normal.

In case of loss or damage to the fuel tank cap, make sure that the replacement cap is for the appropriate vehicle.

Tighten the cap of the fuel tank filler until you hear a "click". This sound shows that the cap of the fuel tank filler is properly tightened.

For versions / markets where provided, turn the key clockwise until it stops. It is not necessary to apply an additional load on the key to complete the tightening of the cap. Only in the case where the cap has been tightened properly, it will be possible to remove the ignition key from the cap.

After each refuelling, make sure the fuel filler cap is securely tightened.



**WARNING** When the gun distributor fuel "snaps" or interrupts the supply, the tank is nearly full and you can run two additional top-ups after shooting automatic.



## **TOPPING UP AdBlue® DIESEL EMISSIONS ADDITIVE (UREA)**

### **Preliminary Conditions**

AdBlue® (UREA) freezes at temperatures lower than -11 °C. If the vehicle stands for a long time at this temperature refilling could be difficult. For this reason, it is advised to park the vehicle in a garage and/or heated environment and wait for the AdBlue® (UREA) to return to liquid state before topping up.

Proceed as follows:

- park the vehicle on ground level;
- stop the engine by turning the ignition device to MAR;
- open the fuel flap A (A)fig. 256 and then unscrew and remove the cap (C) (blue colour) from the AdBlue® (UREA) filler.

### **Refilling with nozzles**

You can fill up at any AdBlue® (UREA) distributor.

Proceed as follows:

- insert the AdBlue® (UREA) nozzle

in the filler, start refilling and stop refilling at the first shut-off (the shut-off indicates that the AdBlue® (UREA) tank is full).

Do not proceed with the refilling and remove the nozzle to prevent spillage.

### **Refilling with containers**

Proceed as follows:

- check the expiration date;
- read the advice for use on the label before pouring the content of the bottle into the AdBlue® (UREA) tank;
- if systems which cannot be screwed in (e.g. tanks) are used for refilling, after the indication appears on the instrument panel display (refer to the "Warning lights and messages" chapter), fill the AdBlue® (UREA) tank with no more than 10 litres;
- if containers which can be screwed to the filler are used, the reservoir is full when the AdBlue® (UREA) level in the container stops pouring out. Do not proceed further.

### **Operations after refilling**

Proceed as follows:

- fit the cap (C)fig. 256 back on the AdBlue® (UREA) filler by turning it clockwise and screwing it completely;
- set the ignition device to MAR (it is not necessary to start the engine);

wait for the indication on the instrument panel to switch off before moving the vehicle. The indication may stay on for a few seconds to approximately half a minute.

If the engine is started and the vehicle is moved, the indication will remain on for longer. This will not compromise engine operation;

if the AdBlue® (UREA) was topped up when the tank was empty, refer to the "Refilling" chapter, and wait for 2 minutes before starting the engine.

**IMPORTANT** If AdBlue® (UREA) is spilled out of the filler neck, clean up well the area and proceed to filling up again. If the liquid crystallises, eliminate it with a sponge and warm water.

### **WARNING**

**DO NOT EXCEED THE MAXIMUM LEVEL:** this could cause damage to the reservoir. AdBlue® (UREA) freezes at under -11 °C. Although the system is designed to operate below the freezing point of the UREA, it is advisable not to fill the tank beyond the maximum level because if the AdBlue® (UREA) freezes the system can be damaged. Follow the instructions in the "Topping up AdBlue® diesel emissions additive (UREA)" paragraph in this section.



- ❑ If the AdBlue® (UREA) is spilled on painted surfaces or aluminium, immediately clean the area with water and use absorbent material to collect the fluid that has been spilled on the ground.
- ❑ Do not try to start the engine if the AdBlue® (UREA) was accidentally added to the Diesel fuel tank, this can result in serious engine damage, contact a Fiat Dealership.
- ❑ Do not add additives or other fluids to AdBlue® (UREA); doing so could damage the system.
- ❑ The use of non-conforming or degraded AdBlue® (UREA) may lead to indications appearing on the instrument panel display (see "Warning lights and messages" chapter).
- ❑ Never pour AdBlue® (UREA) into another container: it could be contaminated.
- ❑ In case of damage to the sewage system of exhaust gas resulting from the use of additives / tap water, the introduction of diesel fuel, or at least by not fulfilling the requirements, the warranty expires.
- ❑ If the AdBlue® (UREA) runs out, refer to the "Warning lights and messages" chapter to continue using the vehicle normally.

### AdBlue® (UREA) storage

AdBlue® (UREA) is considered a very stable product with a long shelf life. Stored at temperatures LOWER than 32°C, it has a shelf life of at least one year. Follow the instructions on the label of the container.

### AdBlue® (UREA) tank topping in cold environments

Since AdBlue® (UREA) starts to freeze around -11°C, the vehicle is equipped with an automatic system of heating UREA that allows the system to function properly at temperatures below -11°C.

If the vehicle remains idle for a long period at temperatures below the -11°C, the AdBlue® (UREA) in the tank might freeze.

If the AdBlue® (UREA) tank was filled beyond the maximum level and freezes, it can be damaged; for this reason it is advisable not to exceed the maximum level of the tank.

Pay extra attention to avoid exceeding the maximum level when you use portable containers for topping up.

### Fuel storage - Diesel Fuel



In case of the storage of massive amounts of fuel, good maintenance is essential. The fuel contaminated

with water favours the proliferation of "microbes".

These microbes create a "slime" that can clog the filter system and fuel pipes. Remove water from the supply tank and regularly replace the filter pipe.

IMPORTANT When a Diesel engine runs out of fuel, air is blown through the fuel system.

### Fuel - Vehicle compatibility identification - Graphic symbol for informing consumers in accordance with EN16942

The symbols shown below aid recognising the correct fuel type to be used on your vehicle. Before proceeding with refuelling, check the symbols inside the fuel filler flap (where provided) and compare them with the symbols shown on the fuel pump (where provided).

### Symbols for diesel fuelled vehicles



**B7:** Diesel containing up to 7% (V/V) of FAME (Fatty Acid Methyl Esters) compliant with **EN590**



## IMPORTANT

**176)** Do not approach naked flames or lit cigarettes to the fuel tank filler: fire risk. Keep your face away from the fuel filler to prevent breathing in harmful vapours.

**177)** To avoid fuel spillage and the exceeding of the maximum level, avoid topping up after filling the tank.

**178)** Any fuel pumping in portable containers located on a floor can cause a fire. Danger of burns. Always put the fuel container on the ground during filling. Avoid using contaminated fuel: a fuel contaminated with water or earth can cause serious damage to the engine fuel feed system. Proper maintenance of the fuel filter, of the engine and the fuel tank is essential.

**179)** Do not open the fuel system at high pressure with the engine running. The operation of the engine creates a high fuel pressure. A jet of high-pressure fuel can cause serious injury or death.



## WARNING

**69)** Only refuel with automotive diesel complying with the European specification EN590. The use of other products or mixtures may damage the engine beyond repair and consequently invalidate the warranty, due to the damage caused. If you accidentally introduce other types of fuel into the tank, do not start the engine. Empty the tank. If the engine has been run for even an extremely limited amount of

*time, you must not only drain the fuel tank, but the rest of the supply circuit as well.*

## ADBLUE® (UREA) ADDITIVE FOR DIESEL EMISSIONS

The vehicle is equipped with an AdBlue® (UREA) injection system and Selective Catalytic Reduction to meet emission standards.

These two systems ensure compliance with the diesel emissions requirements; at the same time, they ensure fuel-efficiency, handling, torque and power. For messages and system warnings, refer to the "Warning lights and messages" chapter in the "Knowing the instrument panel" section.

AdBlue® (UREA) is considered a very stable product with a long shelf life. Stored at temperatures LOWER than 32°C, it has a shelf life of at least one year.

For more information on the AdBlue® (UREA) liquid type, see the "Fluids and lubricants" chapter in the "Technical Specifications" section.

The vehicle is provided with an automatic AdBlue® (UREA) heating system when the engine starts allowing the system to work correctly at temperatures lower than -11 °C.

WARNING! AdBlue® (UREA) freezes at temperatures lower than -11 °C.

## LOADING ADVICE

The Fiat Ducato version used by you has been designed and type approved on the basis of certain maximum weights (see "Weights" table in the "Technical Specifications" section): kerb weight, payload, gross vehicle weight, maximum weight on front axle, maximum weight on rear axle, towable weight.

WARNING The maximum permitted load on the floor fastenings is 500 kg; the maximum permitted load on the side panel is 150 kg.

WARNING For versions with right and left side flaps, it is advisable to reposition the release lever in the closed position before lowering the sides.

 **180) 181) 182)**

 **70)**

In addition to these general precautions, some simple precautions can improve driving safety, travelling comfort and vehicle durability:  
 distribute the load evenly over the platform: if it is necessary to



concentrate it in a single area, choose an area mid-way between both axles;   
 ☐ lastly, remember that the dynamic behaviour of the vehicle is affected by the weight transported: in particular, the stopping distances are longer, especially at high speed.



### IMPORTANT

**180)** *Bumpy roads and abrupt braking may cause unexpected load shifting with consequently hazardous situations for the driver and passengers: before setting off, secure the load tightly using the partition and appropriate hooks, steel cables, ropes or chains strong enough to hold the items to be secured.*

**181)** *Even when the vehicle is stopped on a steep hill or side slope, opening the rear or side doors could cause unsecured goods to fall out.*

**182)** *If you wish to carry a reserve of fuel in a can, observe the legal restrictions and only use a can that is type-approved and properly secured to the load anchoring eyebolts. In the event of a collision the fire risk is increased all the same.*



### WARNING

**70)** *Each of these must be strictly observed and MUST NEVER BE EXCEEDED in any case. In particular, ensure that you never exceed the maximum permitted weights on the front*

*and rear axles when arranging the load on the vehicle (particularly if the vehicle is equipped with a specific trim level).*

## TOWING TRAILERS

### WARNINGS

The vehicle must be provided with a type-approved tow hook and adequate electrical system to tow caravans or trailers. Installation should be carried out by specialised personnel who will issue the required papers for travelling on roads.

Install any specific and/or additional rear-view mirrors as specified by the Highway Code. Remember that when towing a trailer, steep hills are harder to climb, the braking spaces increase and overtaking takes longer depending on the overall weight.

Engage a low gear when driving downhill, rather than constantly using the brake.

The weight of the trailer on the vehicle tow hook will reduce the loading capacity of the vehicle by the same amount. Consider the weight of the trailer fully laden, including accessories and luggage, to make sure you do not exceed the maximum towable weight (shown on the vehicle registration document).

Do not exceed the speed limits specific to each country you are driving in, in the case of vehicles towing trailers. In any case, the top speed must not exceed 100 km/h.

You are advised to fit a suitable stabiliser to the trailer drawbar.

In the vehicles equipped with parking sensors, after fitting the tow hook malfunctioning warnings may be displayed, as some parts (tow bar, ball tow hook) may be within the sensor detection range. In this case the detection range must be adjusted or the parking assistance function must be deactivated.

183) 184)

### INSTALLING THE TOW HOOK

The towing device should be fastened to the body by specialised technicians according to any additional and/or integrative information supplied by the Manufacturer of the device.

The towing device must meet current regulations with reference to Directive 94/20/EC and subsequent amendments.

For any version the towing device used must match the towable weight of the vehicle on which it is to be installed. For the electric connection a standard connector should be used which is

generally placed on a special bracket normally fastened to the towing device, and a special ECU for external trailer light control must be installed on the vehicle. For the electrical connection, 7 or 13 pin 12 VDC connections are to be used (CUNA/UNI and ISO/DIN Standards). Follow the instructions provided by the vehicle manufacturer and/or the tow hitch manufacturer. An electric brake should be supplied directly by the battery through a cable with a cross section of no less than 2,5 mm<sup>2</sup>.

**WARNING** Electric brakes or other devices must be used with engine running. In addition to the electrical branches, the electric system of the vehicle can only be connected to the supply cable for an electric brake and to the cable for an internal light, though not above 15W. For connections use the preset control unit with battery cable no less than 2.5 mm<sup>2</sup>.

**WARNING** The trailer tow hook contributes to the length of the vehicle. When installing on long wheelbase versions, it is only possible to install removable tow hooks because the total vehicle length limit of 6 metres is exceeded. If no trailer is fitted, the hook must be removed from the attachment

base and it must not exceed the original length of the vehicle.

**WARNING** If you wish to leave the tow hook fitted without towing a trailer, it is advisable to contact a Fiat Dealership for the relevant system update operations because the tow hook could be detected as an obstacle by the central sensors.

### Installation diagram for Van versions fig. 257

The tow hook structure must be fastened in the points shown by the symbol Ø using a total of 6 M10x1.25 screws and 4 M12 screws.

The internal back plates must be at least 5 mm thick. MAX LOAD ON BALL: 100/120 kg depending on the payload (see the “Weights” table in the “Technical Specifications” section).



To install a tow hook, the bumpers must be trimmed as described in the supplier's installation kit.

### Installation diagram for Truck and Chassis Cab versions fig. 258

Another tow hook specific to Truck and Chassis Cab versions is shown in fig. 258.

The structure Ø must be fixed in the points indicated using a total of 6 M10x1.25 screws and 4 M12 screws. MAX LOAD ON BALL: 100/120 kg depending on the payload (see the “Weights” table in the “Technical Specifications” section).



### IMPORTANT

**183)** *The ABS with which the vehicle may be equipped will not control the braking system of the trailer. Particular caution is required on slippery roads.*

**184)** *Never modify the braking system of the vehicle to control the trailer brake. The trailer braking system must be fully independent from the hydraulic system of the vehicle.*

**185)** *After fitting, screw holes must be sealed to prevent exhaust gas infiltrations.*



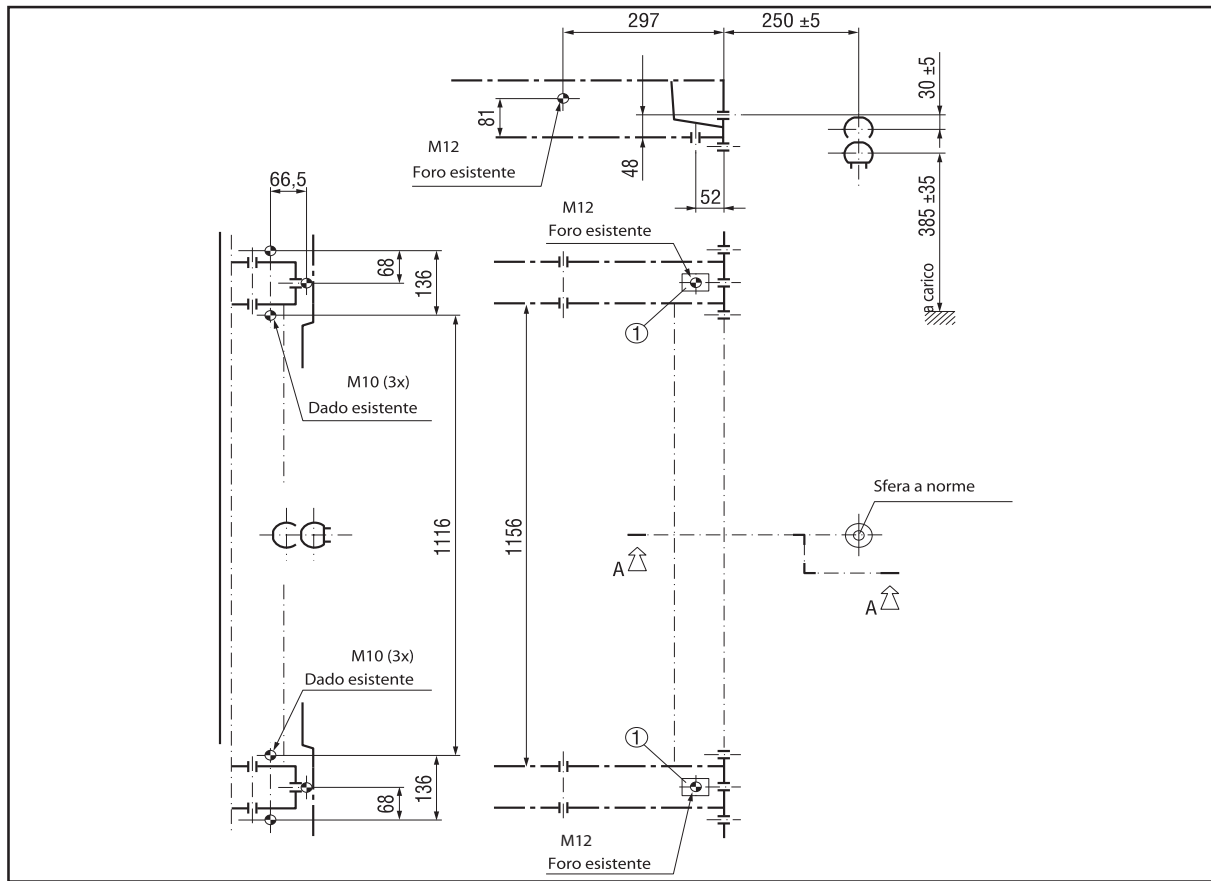

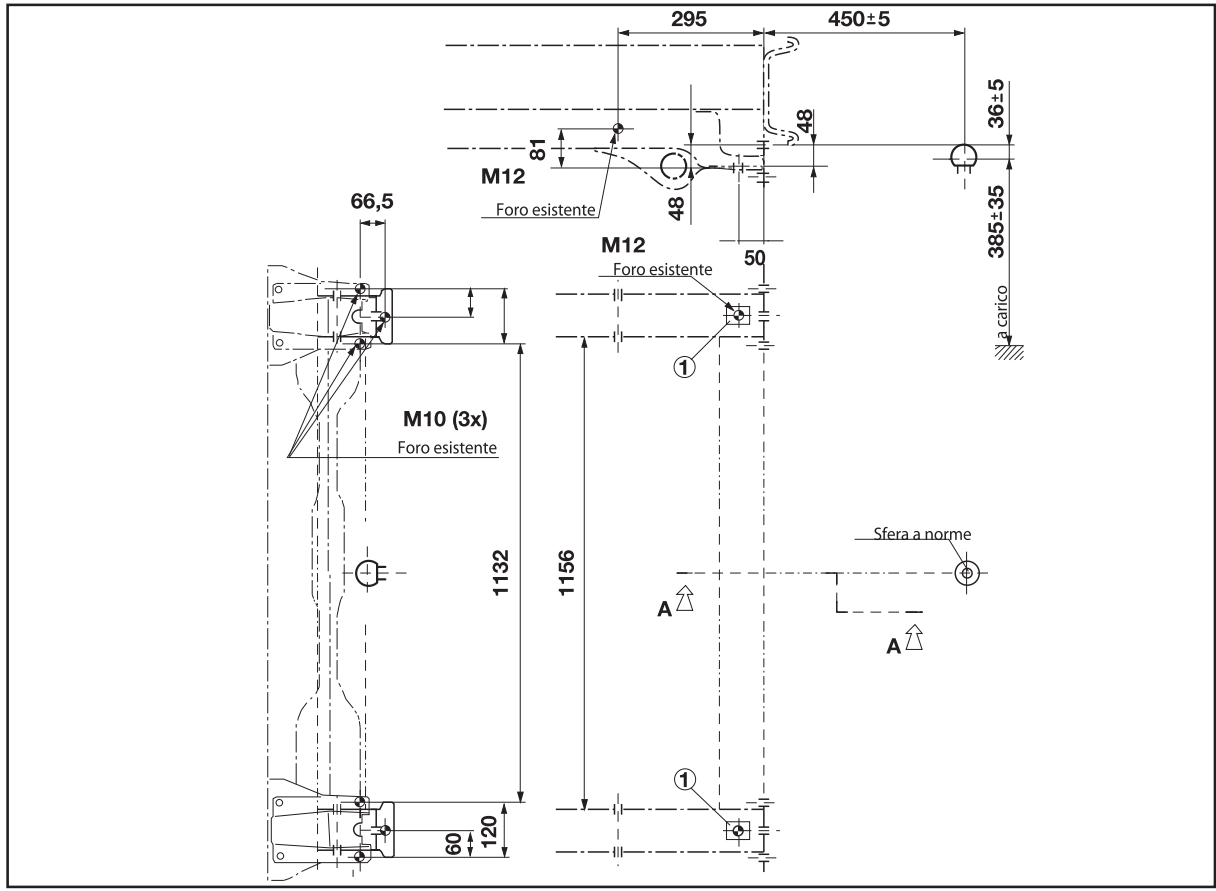

## INSTRUCTIONS FOR USING THE REMOVABLE BALL HEAD TOW BAR

 71) 72) 73) 74) 75) 76)

Before setting off, check the correct locking of the removable ball head tow bar, as follows:

- ❑ The green mark of the handwheel must coincide with the green mark on the tow bar;
- ❑ The handwheel is in the stop position on the tow bar (without slot);
- ❑ locked lock and key removed;
- ❑ ball head bar firmly secured to the housing pipe.

Check by shaking with a hand.

The fitting procedure must be repeated if any of the 4 checked requirements is not met.

If even only one of the requirements is not met the tow hook must not be used, as in this case there is risk of accidents.

Contact the joint manufacturer.

The ball head tow bar can be fitted and removed manually, without needing any tool.

Never use working tools or means, as the mechanism could be damaged.

Never unlock in the case of trailer attached to the vehicle or fitted rack.

When driving without trailer without rack the ball head tow bar must be

removed and the closing cap must always be inserted in the housing pipe. This applies particularly if the visibility of the number plate characters or of the lighting system is reduced.

### Removable ball head tow bar fig. 259 - fig. 260 - fig. 261

(1) Housing pipe / (2) Ball head tow bar / (3) Lock balls / (4) Release lever / (5) Handwheel / (6) Cap / (7) Key / (8) Red mark (handwheel) / (9) Green mark (handwheel) / (10) Green mark (tow bar) / (11) Symbol (release control) / (12) Plug / (13) Pin / (14) No gaps between 2 and 5 / (15) Gap of approximately 5 mm

### Installing the ball head tow bar

Proceed as follows:

1. Remove the plug from the mounting pipe.

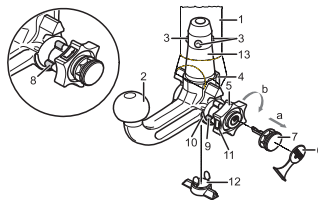

259

F1A0380

### Locked position, driving

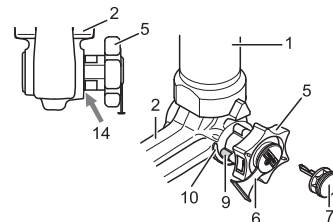

260

F1A0381

### Released position, removed

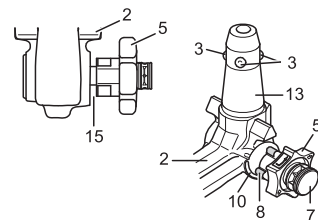

261

F1A0382

The ball head tow bar is usually in the released position when taken out from the boot. This can be observed by the flywheel spaced from the tow bar, corresponding to a slot of approx. 5 mm (see figure) and by the red mark on the flywheel directed to the green mark on the tow bar.

Please note that the tow bar can be installed only when in these conditions. If the locking mechanism of the tow bar



is disengaged before the installation, or at any other time, and is in the locked position, it must be pre-loaded. The locked position can be identified by the green mark of the flywheel coinciding with the green mark of the tow bar and by the flywheel in the stop position on the tow bar, namely without slot (see figure).

The locking mechanism is pre-loaded as follows: with the key inserted and the lock open, extract the flywheel following the direction of the arrow and, to pre-load, rotate according to the direction of the arrow b until the stop. The release lever is engaged and the locking mechanism remains in the pre-loading position even when the flywheel is released. The tow bar must be inserted in the housing pipe with the coupling pin for the installation. Insert from the bottom and push upwards. The mechanism then locks automatically. Keep your hands far from the flywheel, as it rotates during the locking procedure.

2. The tow bar must be inserted in the housing pipe with the coupling pin for the installation. Insert from the bottom and push upwards. The mechanism then locks automatically. Keep your hands far from the flywheel, as it rotates during the locking procedure.

3. Close the lock and always remove the key. The key cannot be removed when the lock is released. Apply the protection cap on the lock.

### Removing the tow bar

Proceed as follows:

1. Remove the protection cap from the lock and press it on the key grip. Open the lock with the key.
2. Hold the tow bar firmly, remove the flywheel following the direction of the arrow and rotate according to the direction of the arrow b until stopping, so as to remove till the extracted position. Then remove the tow bar from the housing pipe. The flywheel can then be released; it autonomously stops in the released position.
3. Arrange the tow bar in the luggage compartment so that it cannot be dirtied or damaged by other transported objects.
4. Insert the suitable plug in the mounting pipe.



### WARNING

**71)** The removable ball head bar must be repaired and taken apart by the manufacturer only.

**72)** The accompanying plate must be in a highly visible point of the vehicle, near the mounting pipe or inside the boot.

**73)** To ensure correct operation of the system, periodically remove all dirt deposits from the ball head bar and from the mounting pipe. The mechanical components must be serviced at the specified intervals. The lock must only be treated with graphite.

**74)** Periodically lubricate the joints, the sliding surfaces and the balls with grease without resin or oil. Lubrication is also a further corrosion protection.

**75)** If the vehicle is washed with high-pressure jets, the ball head bar must be removed and the dedicated cap fitted. The ball head bar must never be treated with steam jets.

**76)** Two keys are supplied together with the removable ball tow bar. Note down the key number on the pawl for any following order and keep it.



## **PROLONGED VEHICLE INACTIVITY**

If the vehicle needs to be off the road for longer than one month, the following precautions must be taken:

- ❑ park the vehicle indoors in a dry and, if possible, well-ventilated place;
- ❑ engage a gear;
- ❑ check that the parking brake is not activated;
- ❑ disconnect the battery:

- **For versions with Start&Stop system:** the procedure must be performed by disconnecting the connector (A) (pressing the button (B)) from the sensor (C) monitoring the battery conditions, on the negative pole (D) of the battery fig. 262.

- **For versions without Start&Stop system:** disconnect the negative terminal from the battery terminal. If the vehicle is equipped with a battery disconnection function (disconnecter), see the description of the disconnection procedure in the "Battery disconnection function (disconnecter)" chapter.

- ❑ clean and protect the painted parts using protective wax;

- ❑ clean and protect the shiny metal parts using special compounds available commercially;
- ❑ sprinkle talcum powder on the windscreen and rear window wiper rubber blades and lift them off the glass;
- ❑ slightly open the windows;
- ❑ cover the vehicle with a piece of fabric or perforated plastic sheet. Do not use compact plastic tarpaulins, which prevent humidity from evaporating from the surface of the vehicle;
- ❑ inflate tyres to +0.5 bar above the standard prescribed pressure and check it periodically;
- ❑ do not drain the engine cooling system.

**WARNING** If the vehicle is equipped with an alarm system, switch off the vehicle alarm with the remote control.

**WARNING** After turning the ignition key to STOP and having closed the driver side door, wait at least one minute before disconnecting the electrical supply from the battery. When reconnecting the electrical supply to the battery, make sure that the ignition key is in the STOP position and the driver's door is closed.

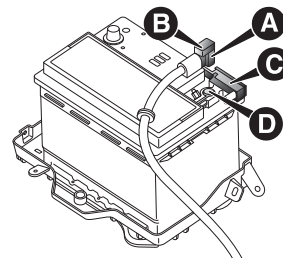

262

F1A0137

## **BATTERY DISCONNECTION FUNCTION (DISCONNECTOR)**

(for versions/markets, where provided)  
The battery disconnector is located in the lower part of the dashboard under the steering column. To access the disconnector, open the cover that protects the device fig. 263. The battery disconnection function is enabled by moving the device from position (A) to position (B) fig. 264, with the help of the ignition key.  
The battery will be disconnected, by interrupting the earth lead, about 7 minutes after.

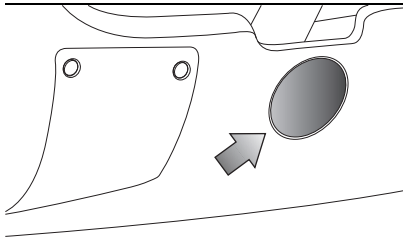

263

F1A0756

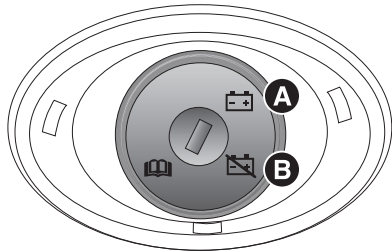

264

F1A0757

This 7 minute period is necessary to:

- allow the driver to get out of the vehicle and lock the doors using the remote control

**ATTENTION:** If the vehicle is equipped with an anti-theft system, it is absolutely necessary that the doors are locked with the mechanical key and not with the remote control. Locking with the remote control will activate the anti-theft system. At the end of the 7 minutes, when the battery would be

disconnected, the anti-theft system would recognise this as a break-in attempt.

- guarantee that all the vehicle electrical systems have been deactivated.

With the battery disconnected, access to the vehicle will only be possible by unlocking the driver's door using the mechanical lock.

To restore the battery connection, insert the ignition key into the disconnecter and move it to position (A) fig. 264, at which point the vehicle can be started normally.

If the battery is disconnected, it may be necessary to set certain electrical devices again (e.g. clock, date, etc.).





## IN CASE OF EMERGENCY

*Have a flat tyre or a burnt-out bulb?  
At times, a problem such as these may  
interfere with your driving experience.  
The pages on emergencies can help  
you to deal with critical situations  
independently and calmly.  
In an emergency, we recommend that  
you call the phone number found in the  
Warranty Booklet.  
It is also possible to call the  
00 800 3428 0000 freephone number  
to search the nearest Fiat Dealership.*

|  |     |
|--|-----|
| HAZARD WARNING LIGHTS .....                        | 223 |
| ASSIST CALL .....                                  | 223 |
| HELP CALL .....                                    | 225 |
| Uconnect Box SYSTEM                                |     |
| BATTERY .....                                      | 228 |
| REPLACING A BULB .....                             | 228 |
| REPLACING AN EXTERIOR<br>BULB .....                | 232 |
| REPLACING INTERIOR BULBS ....                      | 237 |
| FUSES.....   | 238 |
| CHANGING A WHEEL .....                             | 238 |
| TYRE REPAIR KIT .....                              | 243 |
| JUMP STARTING .....                                | 246 |
| RECHARGING THE BATTERY .....                       | 247 |
| ADDITIONAL HEATER FUEL<br>CUT-OFF SWITCH .....     | 248 |
| FUEL CUT-OFF SYSTEM .....                          | 249 |
| AUTOMATIC TRANSMISSION<br>GEAR LEVER RELEASE ..... | 249 |
| TOWING THE VEHICLE .....                           | 251 |

## HAZARD WARNING LIGHTS

They are switched on by pressing the switch (A) fig. 265 or (A) fig. 266, according to the versions, regardless of the position of the ignition key.

Warning lights  and  are lit up in the instrument panel when this device is activated. Press the switch (A) fig. 265 again to turn the lights off.

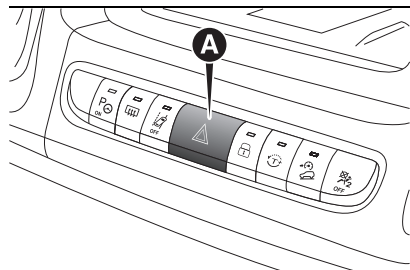

265

F1A0642

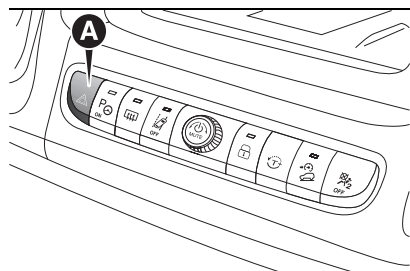



266

F1A0674

**WARNING** The use of hazard warning lights is governed by the highway code of the country you are in. Comply with legal requirements.

## EMERGENCY BRAKING

(for versions/markets, where provided)

In the event of emergency braking the hazard warning lights come on automatically, as do the  and  warning lights in the panel. The function switches off automatically when the nature of the braking changes.

This function complies with the relevant legislation currently in force.

## ASSIST CALL

(for versions/markets, where provided)

The vehicle is provided with on-board assistance functions designed to provide support in the event of vehicle malfunctions (ASSIST). They are managed via the Uconnect Box.

The ASSIST function is activated:

automatically (for versions/markets, where provided) following malfunctions of the braking system, fuel system, engine, etc.

manually, by pressing the ASSIST button fig. 267 located on the ceiling light or by selecting the appropriate menu on the **Uconnect™** system (for versions/markets, where provided):



Assist

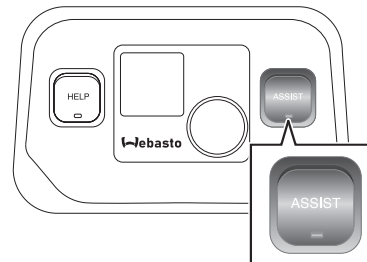

267

F1A0749

The ASSIST function is activated with:

- ignition device at MAR;
- ignition device in STOP position and **Uconnect™** system display on.

After the ASSIST function (for versions/markets, where provided) has been activated automatically or manually, pressing the corresponding button will send position data to the operational centre and make a voice call to an operator.

**NOTE** If the Assist function does not work, the system fault will be indicated on the display. If this happens, go to an authorised workshop to have the function repaired as soon as possible.  
**NOTE** The correct operation of the ASSIST services will be guaranteed only by a good network coverage.



**WARNING** The ASSIST function may not be available for the first minute after the vehicle is started.

Privacy: GPS location is always active for ASSIST. Deactivating it via the "Settings" menu of the **Uconnect™** system will make some with other services unavailable (see the "Settings" paragraph of the **Uconnect™** system for more details).

**WARNING** The  icon at the top of the **Uconnect™** system display indicates that the geolocation function is active (ON). When geolocation is on, the vehicle position is tracked to enable the functions that require it. When geolocation is off, the vehicle position is only tracked by the navigation, safety, insurance and driver assistance systems (where provided). See the **Uconnect™** system "Settings" paragraph to deactivate the function.

### **MANUAL ASSIST CALL**

(for versions/markets, where provided)  
Pressing the ASSIST button located on the front ceiling light fig. 267 and/or on the display of the **Uconnect™** system (for versions/markets, where provided) to call to one or more of the following services:

**Roadside assistance:** if case of need, a connection will be established with the roadside assistance authority which will receive the vehicle type and its position directly. Additional roadside assistance charges may apply.

**Customer care** (for versions/markets, where provided): Customer service to support all vehicle problems.

The LED on the ASSIST button located on the ceiling light will turn green once connected to an ASSIST operator and will turn off when the connection is ended.

**NOTE** If the ASSIST call button is pressed by mistake, the call can be ended by pressing the same button again or by pressing the cancel button on the **Uconnect™** system display.

Once the connection has been established, the following data will be automatically transmitted, as authorised by the customer:

- indication that the occupant has made an ASSIST call;
- vehicle brand;
- the most recent known GPS coordinates of the vehicle;
- the type of error that occurred on the vehicle that automatically sent the ASSIST request (in the case of an automatic call - for versions/markets, where provided).

The call will be made through the vehicle sound system to provide any additional information about the assistance request.

If the system is unable to establish the voice call, or the line disconnects due to insufficient coverage, the ASSIST service will make several attempts to try to call the operational centre.

**WARNING** If you have not subscribed to the related services or the My Assistant package has expired or is unavailable for purchase, the ASSIST call will not be available. For further information visit the Fiat official website.

**WARNING** If the ASSIST call system detects a malfunction, it is indicated by the red LEDs on the ceiling light and a corresponding message on the **Uconnect™** system display. Contact a Fiat Dealership as soon as possible.

If an emergency call (HELP) is active and an ASSIST call is requested, the latter will not be delivered.

### **GENERAL DISCLAIMER**

#### **Personal data & privacy**

The Manufacturer collects, processes and uses the personal data of the vehicle in accordance with legal requirements. Read more about the

general conditions of service and data protection policies on the Fiat official website.

❑ The customer is solely responsible for using the services in the vehicle, even if by other people, and shall inform all users and occupants of the vehicle about the services and the functions and limits of the system.

### Operating prerequisites

❑ To use some of the Uconnect Services you need to register on the dedicated portal that can be accessed from the Fiat official website, activate and login to your devices.

❑ Uconnect Services not available in all markets and is subject to limitations depending on **Uconnect™** system type, location and duration of the services.

❑ The full operation of the Uconnect Services, including the ASSIST call, is subject to mobile network and GPS geolocation coverage, without which the proper provision of services is not guaranteed. Coverage may not be guaranteed in places such as tunnels, garages, multi-storey car parks, mountains.

❑ The services may be unavailable in the event of mobile network overload or problems related to the vehicle power source (e.g. low battery).

❑ When using the services, customers shall keep their passwords secret for strictly personal use and not to disclose them to third parties.

## HELP CALL

(for versions/markets, where provided)

The vehicle is equipped with on-board assistance functions designed to provide support in the event of an accident and/or emergency (HELP). They are managed via the Uconnect Box.

The HELP function is activated:

❑ automatically in the event of a major collision recorded by the device aboard the vehicle;

❑ manually, by pressing the HELP button located on the ceiling light fig. 268 (for versions/markets, where provided) or by means of the dedicated menu on the **Uconnect™** system:



HELP

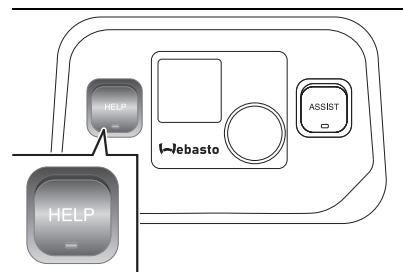

268

F1A0750

**WARNING** If the **HELP** emergency service is activated, the call will be routed automatically to a private Call Centre. Note that whenever the text refers to the HELP call, it is to be considered managed by private service providers. The HELP call service is not the e-call system for emergency calls set out in the applicable European Community legislation for newly type-approved vehicles.

The HELP service has an expiry. Refer to the My Uconnect website for the latest terms of service.

The HELP function is activated with:

❑ ignition device at MAR;  
❑ ignition device in STOP position and **Uconnect™** system display on.

After the HELP function (for versions/markets, where provided) has been activated automatically or



manually, pressing the corresponding button will send the position data to the operational centre and make a voice call to an operator.

NOTE If the HELP function does not work, the system fault will be indicated on the display. If this happens, go to an authorised workshop to have the function repaired as soon as possible.

NOTE The correct operation of the HELP services will only be guaranteed with good network coverage.

WARNING The HELP function may not be available for the first minute after the vehicle is started.

Privacy: GPS location is always active for HELP. Deactivating it via the "Settings" menu of the **Uconnect™** system will make some with other services unavailable (see the "Settings" paragraph of the **Uconnect™** system for more details).

WARNING The  icon at the top of the **Uconnect™** system display indicates that the geolocation function is active (ON). When geolocation is on, the vehicle position is tracked to enable the functions that require it. When geolocation is off, the vehicle position is only tracked by the navigation,

safety, insurance and driver assistance systems (where provided). See the **Uconnect™** system "Settings" paragraph to deactivate the function.

## MANUAL HELP CALL

(for versions/markets, where provided)

When required, hold the HELP button on the front ceiling light fig. 268 pressed for 2 seconds or press the button on the **Uconnect™** display (for versions/markets, where provided).

The LED on the HELP button will turn green when the call is connected to an HELP operator, and will turn off when the call ends.

NOTE If the HELP call button is pressed by mistake, it is possible to press it again within 10 seconds to cancel the operation or press the cancel button on the **Uconnect™** system display.

Once the connection has been established, the following data will be automatically transmitted to the Operations Centre, as authorised by the customer:

- indication that the occupant has made an HELP call;
- vehicle brand;
- the most recent known GPS coordinates of the vehicle.

If you are able to speak to the operator, do so through vehicle audio to provide

additional information about the request for help.

If the system is unable to establish the voice call, or the line disconnects because of insufficient coverage, the HELP service will try to call the operational centre again for 5 minutes. If the operational centre needs to contact the vehicle again, the system can receive an incoming call, which will be accepted automatically.

WARNING When the service expires, you will not be contacted by any operations centre and the system will warn you of the unavailability of the service.

WARNING If the HELP call system detects a malfunction, it will be indicated:

- during the start-up phase;
- by turning on the red LEDs on the ceiling light and displaying a message on the **Uconnect™** system display when the malfunction is detected. Contact a Fiat Dealership as soon as possible.

WARNING In the event of danger (fire, visible smoke or hazardous road conditions or positions), do not wait for



voice contact with the HELP service operator, but exit from the vehicle immediately and go to a safe place, if in a condition to do so.

**WARNING** Do not place network antennas, CB radios or aftermarket electrical equipment to avoid interference. Such interference could prevent the system from making the emergency call.

**WARNING** Ignoring system fault warnings (red LED on the ceiling light) could mean being unable to make an HELP call when necessary.

Even if the HELP call system is fully functional, factors outside the control of the Manufacturer could interfere with or prevent operation of the HELP call. Such factors can be caused by the vehicle electrical systems not being intact, damage to the HELP system during the accident, satellite signals that are overloaded or unavailable, network congestion, adverse weather conditions, buildings, structures, interference, tunnels, etc.

## GENERAL DISCLAIMER

### Personal data & privacy

❑ The Manufacturer collects, processes and uses the personal data of the vehicle in accordance with legal requirements. Read more about the general conditions of service and data protection policies on the Fiat official website.

❑ The customer is solely responsible for using the services in the vehicle, even if by other people, and shall inform all users and occupants of the vehicle about the services and the functions and limits of the system.

**❑ If the HELP emergency service is activated (for versions and markets where available), the call will be routed automatically to a private Call Centre. Note that whenever the text refers to the HELP call, it is to be considered managed by private service providers.**

### Operating prerequisites

❑ To use some of the Uconnect Services you need to register on the dedicated portal that can be accessed from the Fiat official website, activate and login to your devices.

❑ Uconnect Services not available in all markets and is subject to limitations depending on **Uconnect™** system type, location and duration of the services.

❑ Full functionality of Uconnect Box services, including HELP calls, depends on the mobile network and GPS geolocation coverage, without which the services may not be provided correctly. Coverage may not be guaranteed in places such as tunnels, garages, multi-storey car parks, mountains.

❑ The services may be unavailable in the event of mobile network overload or problems related to the vehicle power source (e.g. low battery).

❑ When using the services, customers shall keep their passwords secret for strictly personal use and not to disclose them to third parties.



## Uconnect Box SYSTEM BATTERY

The Uconnect Box system is provided with an independent battery that allows the operation of some connected services even if the vehicle battery is disconnected.

The system will warn the user of the need to replace this battery by displaying a dedicated message on the display of the **Uconnect™** system (for versions/markets where provided) and by means of a notification via mobile app (for versions/markets, where provided).

Go to a Fiat dealership as soon as possible.

**NOTE** Failure to replace the battery and, consequently, failure to observe the warnings provided by the system could affect or entirely prevent service operation.

**NOTE** Regardless of state of charge, the battery must be replaced every 5 years by a Fiat dealership.

## REPLACING A BULB

### GENERAL INSTRUCTIONS

 **186)** **187)**

 **188)**  **77)**

- When a light is not working, check that the corresponding fuse is intact before replacing a bulb. For the location of fuses, refer to the "Fuses replacement" chapter in this section.
- before changing a bulb check the contacts for oxidation;
- burnt bulbs must be replaced by others of the same type and power;
- always check the headlight beam direction after changing a bulb;

**WARNING** A slight misting may appear on the internal surface of the headlight: this does not indicate a fault and is caused by low temperature and the degree of humidity in the air. Misting will rapidly disappear when the headlights are switched on. The presence of drops inside the headlights indicates infiltration of water. Contact a Fiat Dealership.



### IMPORTANT

**186)** Modifications or repairs to the electric system that are not carried out properly or do not take the system technical specifications into account can cause malfunctions leading to the risk of fire.

**187)** Halogen bulbs contain pressurised gas, in the case of breakage they may burst causing glass fragments to be projected outwards.

**188)** Never disconnect the 12V battery terminals. No operations are allowed on the 12V battery. Always go to a Fiat Dealership.



### WARNING

**77)** Halogen bulbs must be handled holding the metallic part only. Touching the transparent part of the bulb with your fingers may reduce the intensity of the emitted light and even reduce the lifespan of the bulb. In the event of accidental contact, wipe the bulb with a cloth moistened with alcohol and let the bulb dry.

## BULB TYPES

Various types of bulbs are fitted to your vehicle:

**All-glass bulb:** (type A) these are pressure fitted - pull to remove.

---

**Bayonet bulb:** (type B) to remove them press the bulb and turn it anticlockwise.

---

**Cylindrical bulbs:** (type C) release them from their contacts to remove.

---

**Halogen bulbs:** (type D) to remove the bulb, release it and extract it from its seat.

---

**Halogen bulbs:** (type E) to remove the bulb, release it and extract it from its seat.

---

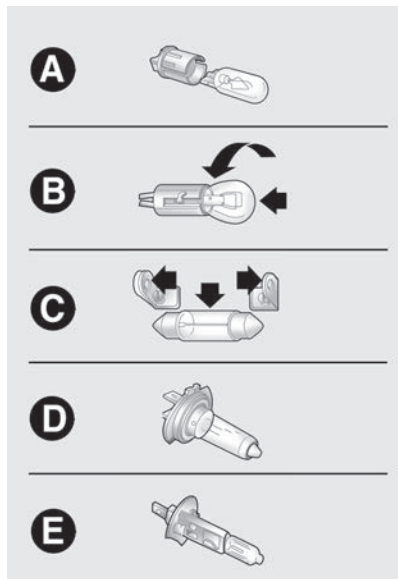

**Light bulbs**

| Light bulbs                               | Type                      | Power                 | Figure ref. |
|---|---------------------------|-----------------------|-------------|
| Main beam headlights                      | H7                        | 55W                   | D           |
|   | FULL LED                  | -                     | -           |
| Dipped beam headlights                    | H7                        | 55W                   | D           |
|   | FULL LED                  | -                     | -           |
| Front side / Daytime running lights (DRL) | W21/5W - LED (*)          | 21/5W                 | B           |
|   | LED (*)                   | -                     | -           |
| Front fog lights (**)                     | H11                       | 55W                   | -           |
| Front direction indicators                | WY21W                     | 21W                   | B           |
|   | LED (*)                   | -                     | -           |
| Side direction indicators                 | W16WF (***) / WY5W (****) | 16W (***) / 5W (****) | A           |
| Rear direction indicators                 | PY21W                     | 21W                   | B           |
| Side lights                               | W5W                       | 5W                    | A           |
| Rear side lights                          | P21/5W                    | 21/5W                 | B           |
| Rear side lights/Brake lights             | P21W                      | 21W                   | B           |
| Third brake light                         | W5W                       | 5W                    | B           |
| Reverse gear                              | W16W                      | 16W                   | B           |
| Rear fog light                            | W16W                      | 16W                   | B           |
| Number plate                              | C5W                       | 5W                    | A           |

| Light bulbs                     | Type   | Power | Figure ref. |
|---------------------------------|--------|-------|-------------|
| Front roof light (movable lens) | 12V10W | 10W   | C           |
| Rear ceiling light              | 12V10W | 10W   | C           |

(\*) Where provided

(\*\*) For versions/markets, where provided

(\*\*\*) XL and Tempo Libero versions

(\*\*\*\*) All other versions



## REPLACING AN EXTERIOR BULB

For the type of bulb and power rating, see the previous chapter "Changing a bulb".

### FRONT LIGHT CLUSTERS

The front light clusters contain the side lights and DRLs (where the LED solution is not provided), dipped beam, main beam and direction indicator bulbs.

Bulbs must be replaced with the headlight removed and placed on a work surface.

To remove the headlight, operate as follows:

- open the bonnet by following the procedure in the "Bonnet" chapter in the "Knowing your vehicle" section;
- disconnect the electrical connector (A) fig. 269 from the headlight;
- undo the screws (B) fig. 270 fixing the headlight to the body, release the headlight from its housing, in the lower part, as shown in fig. 270 and remove the headlight placing it on a work surface;
- follow the steps described below for replacing the bulbs;
- after the replacement, refit the headlight and secure it with the fixing screws (B) fig. 270;

- connect the electrical connector (A) fig. 269 from the headlight.

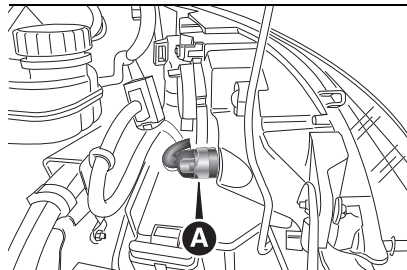

269

F1A0337

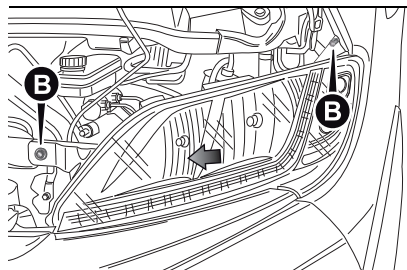

270

F1A0338

The bulbs are arranged inside the light cluster as follows fig. 271:

- (A) direction indicators
- (B) dipped beam headlights
- (C) main beam headlights
- (D) daytime running lights
- (E) side lights/DRLs with LEDs (as an alternative to (D))

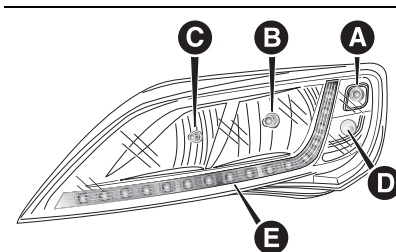

271

F1A0313

To replace a main beam headlight bulb, remove the rubber cap (C) fig. 272.

To replace a dipped beam headlight bulb, remove the rubber cap (B) fig. 272.

To replace a direction indicator or side light/DRL bulb (when not LED), remove the rubber cap (A) fig. 272.

After replacement, refit the rubber caps correctly, ensuring that they are locked in place.

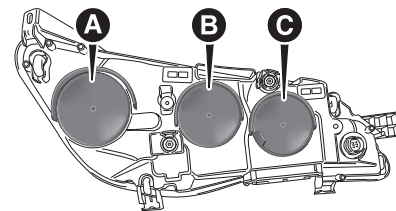

272

F1A0314

## SIDE LIGHTS/DAYTIME RUNNING LIGHTS

To replace the bulb, proceed as follows:

- ❑ remove the protective rubber cover (A) fig. 272;
- ❑ turn the bulb holder (B) fig. 273 anticlockwise;
- ❑ extract the bulb by pulling and replace it;
- ❑ remove the bulb by pushing it slightly and turning it anticlockwise (bayonet mount);
- ❑ refit the bulb holder B by turning it clockwise and making sure that it locks correctly;
- ❑ refit the protective rubber cover (A) fig. 272.

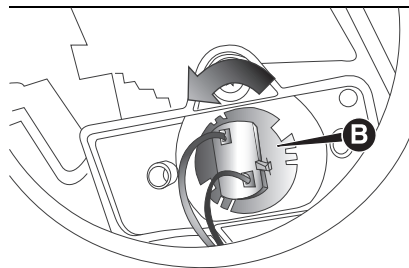

273

F1A0386

## MAIN BEAM HEADLIGHTS

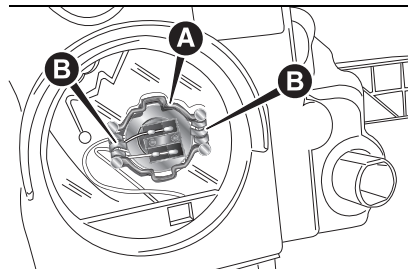

274

F1A0315

To replace the bulb, proceed as follows:

- ❑ remove the protective rubber cover (C) fig. 272;
- ❑ free the bulb holder (A) fig. 274 from the side clips (B) and remove it;
- ❑ disconnect the electrical connector;
- ❑ fit the new bulb, ensuring that the outline of the metal part coincides with the grooves on the curve of the headlight, pressing to engage it with the side clips;
- ❑ reconnect the electrical connector;
- ❑ refit the protective rubber cover (C) fig. 272.

## DIPPED BEAM HEADLIGHTS

With incandescent bulbs

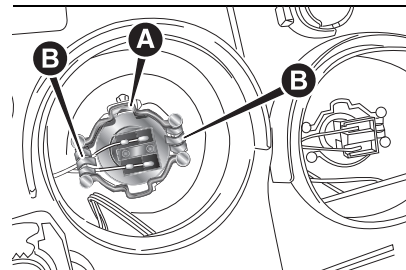

275

F1A0316

To replace the bulb, proceed as follows:

- ❑ remove the protective rubber cover (B) fig. 272;
- ❑ free the bulb holder (A) fig. 275 from the side clips (B) and remove it;
- ❑ disconnect the electrical connector;
- ❑ fit the new bulb, ensuring that the outline of the metal part coincides with the grooves on the curve of the headlight, pressing to engage it with the side clips;
- ❑ reconnect the electrical connector;
- ❑ refit the protective rubber cover (B) fig. 272.

## DIRECTION INDICATORS

To replace the bulb, proceed as follows:



- ❑ remove the protective rubber cover (A) fig. 272;
- ❑ turn the bulb holder (B) fig. 276 anticlockwise;
- ❑ extract the bulb by pulling and replace it;
- ❑ remove the bulb by pushing it slightly and turning it anticlockwise (bayonet mount);
- ❑ refit the bulb holder (B) by turning it clockwise and making sure that it locks correctly;
- ❑ refit the protective rubber cover (A) fig. 272.

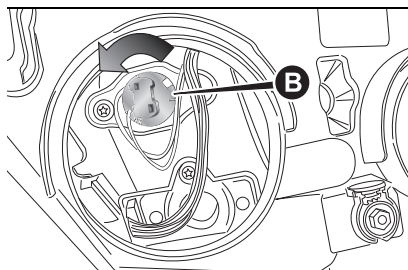

276

F1A0317

### Side

To replace the bulb, proceed as followsfig. 277:

- ❑ move the mirror manually to permit access to the two fixing screws (A);
- ❑ using the Phillips screwdriver provided, undo the screws and extract the bulb holder assembly, releasing it from the teeth;

- ❑ undo the bulb and replace bulb (B), turning it anticlockwise.

### VERSIONS WITH LED LIGHTS

(for versions/markets, where provided)

For replacing these bulbs, contact a Fiat Dealership.

### FOG LIGHTS

(for versions/markets, where provided)

To replace the front fog light bulbs, proceed as follows:

- ❑ steer the wheel completely inwards;
- ❑ undo the screw (A) and remove the inspection flap (B) fig. 278;

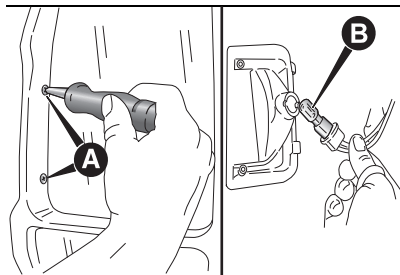

277

F1A0195

- ❑ adjust the clip (C) fig. 279 and disconnect the electrical connector (D);
- ❑ turn and remove the bulb holder (E);
- ❑ release the bulb and replace it;
- ❑ refit the new bulb and carry out the procedure described previously in reverse.

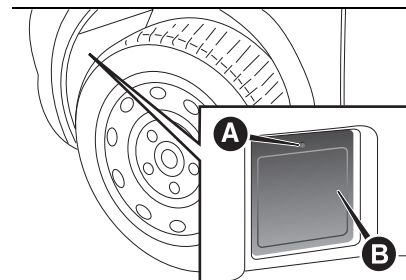

278

F1A0361

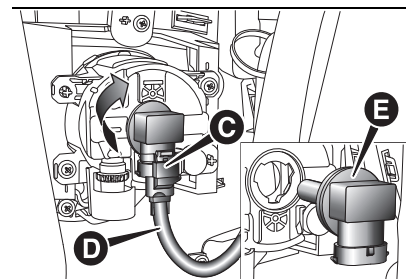

279

F1A0362

### REAR LIGHT CLUSTERS

The bulbs are arranged inside the light cluster as follows fig. 280:

- (A) brake/side lights
- (B) sidelights
- (C) direction indicators
- (D) reverse gear lights
- (E) rear fog lights

To change the bulb, proceed as follows fig. 281, fig. 282:



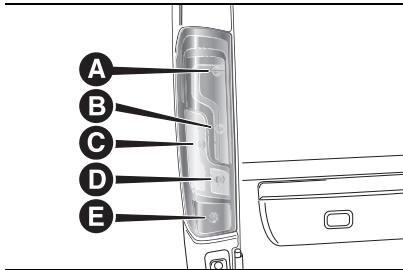

280

F1A0318

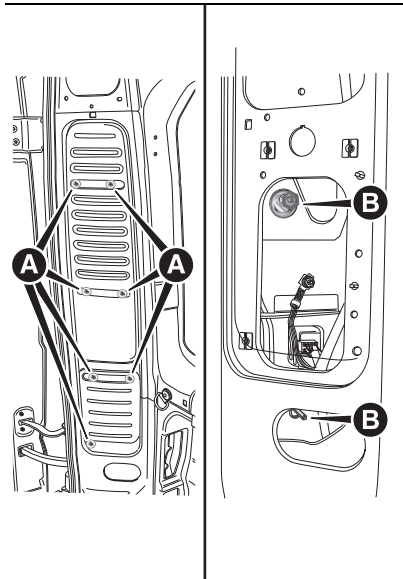

281

F1A0319

- open the rear swing door
- undo the 7 fixing screws (A) of the plastic cover;
- undo the two fixing screws (B);
- extract the unit outwards and disconnect the electrical connector;
- unscrew the screws (C) using the screwdriver provided and remove the bulb holder;

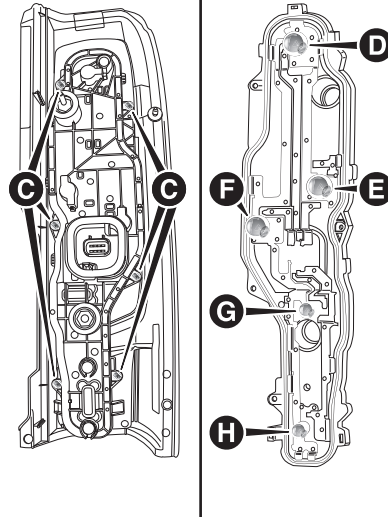

282

F1A0320

- remove the bulb to be replaced (D), (E), (F) pushing it slightly and turning it anticlockwise (bayonet mount) and

- replace it; extract the bulb (G), (H) pulling it outwards;
- refit the bulb holder and tighten the screws (C);
- reconnect the electrical connector, correctly reposition the unit on the bodywork of the vehicle and then tighten the fixing screws (B);
- refit the plastic cover fastening it with the 7 fixing screws (A).



For truck and chassis cab versions:

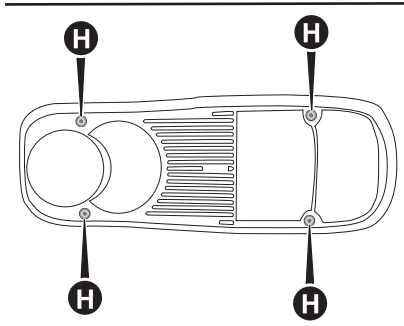
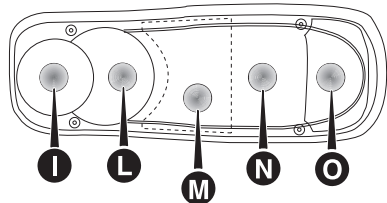

283

F1A0200

Undo the four screws (H) fig. 283 and replace the bulbs:

- (I) bulb for rear fog light
- (L) bulb for reversing light
- (M) bulb for side light
- (N) bulb for brake light
- (O) direction indicator bulb.

### THIRD BRAKE LIGHTS

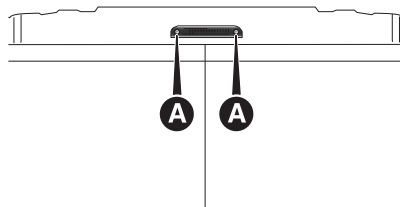

284

F1A0204

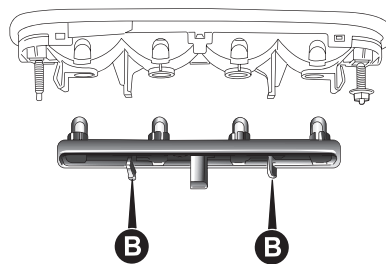

285

F1A0205

To replace the bulb proceed as follows:

- undo the two fixing screws (A) fig. 284;
- extract the lens unit;
- press the tabs (B) fig. 285 together and remove the bulb holder;
- remove the snap-fitted bulb and replace.

### NUMBER PLATE LIGHTS

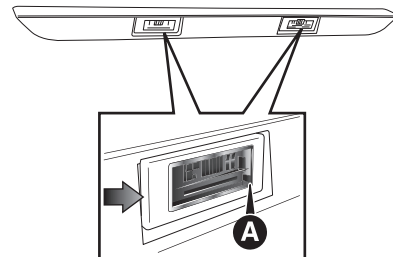

286

F1A0206

To replace the bulb proceed as follows:

- operate in the point indicated by the arrow and remove the lens unit (A) fig. 286;
- change the bulb releasing it from the side contacts and making sure the new bulb is correctly fastened between the contacts;
- refit the snap-fitted lens unit.

### SIDE LIGHTS

(for versions/markets, where provided)

#### □ For extra-long van versions

Proceed as follows:

- undo the two fixing screws (C) fig. 287 and remove the headlight;
- remove the bulb holder (D) on the rear of the light cluster, turning through 1/4 turn;
- remove the snap-fitted bulb and replace.

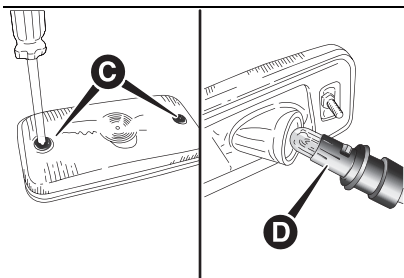

287

F1A0207

### ❑ Chassis cab versions with platform

Proceed as follows:

- remove the bulb holder on the rear of the light cluster, turning through 1/4 turn;
- remove the snap-fitted bulb and replace.

## REPLACING INTERIOR BULBS

For the type of bulb and relevant power rating, see the “Changing a bulb” chapter.

### FRONT CEILING LIGHT

To replace the bulbs, proceed as follows:

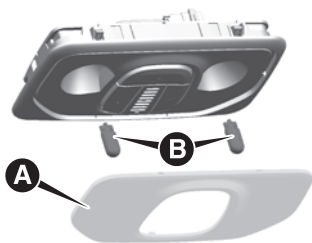

288

F1A0745

- ❑ With the help of a small tool, remove the transparent part of the ceiling light (A) fig. 288;
- ❑ pull the bulb (B) fig. 288 towards you and replace it;
- ❑ reposition the lens of the ceiling light (A) making sure that it is locked into place.

### LED LOAD COMPARTMENT CEILING LIGHT

(for versions/markets, where provided)  
Contact a Fiat Dealership for replacing an LED front ceiling light.

## REAR CEILING LIGHT

To replace the bulbs, proceed as follows:

- ❑ operate in the points shown by the arrow and remove ceiling light (D) fig. 289;
- ❑ open protective flap (E) fig. 290;
- ❑ change the bulb (F) fig. 290 releasing it from the side contacts and making sure the new bulb is correctly fastened between the contacts;
- ❑ close the protective flap (E) fig. 290 and re-insert the roof light (D) fig. 289 in its housing, making sure that it locks into place.

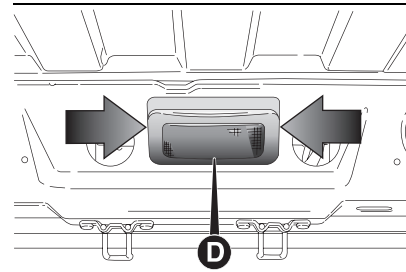

289

F1A0210



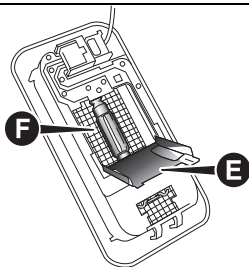

290

F1A0211

## FUSES

⚠ 189) 190) ⚠ 78)



### IMPORTANT

**189) Replacement of a fuse.** All work may be performed only by a Fiat Dealership or a qualified repair workshop. The replacement of a fuse by a third party may cause a serious vehicle fault.

**190) Installation of electrical accessories.** The vehicle's electrical circuit is designed to function with standard or optional equipment, before installing other electrical equipment or accessories in the vehicle contact a Fiat dealership or a qualified repair workshop.



### WARNING

**78)** The manufacturer shall not be held liable for expenses resulting vehicle is repair or anomalies resulting from the installation of accessories not provided or recommended by the manufacturer and not installed according to specifications, in particular when the combined consumption of all additional equipment connected exceeds 10 mA.

## CHANGING A WHEEL

### GENERAL INSTRUCTIONS

Wheel replacement and correct use of the jack and spare wheel (for versions/markets, where provided) call for some precautions, which are listed below.

⚠ 191) 192) 193) 194) 195)

#### Please note that:

- the jack weight is 4.5 kg;
- the jack requires no adjustment;
- the jack cannot be repaired: in the event of a fault it must be replaced by another original one;
- no tool other than its cranking device may be fitted on the jack.

⚠ 196)

#### To change a wheel, proceed as follows:

- stop the vehicle in a position that is not dangerous for oncoming traffic

where you can change the wheel safely. The ground must be flat and sufficiently compact;

- stop the engine and engage the parking brake;

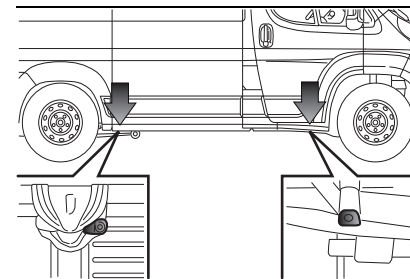

291

F1A0168

- engage first gear or reverse;
- put on the reflective safety jacket (compulsory by law in certain countries) before getting out of the vehicle;
- indicate that the vehicle has broken down using the devices required by the law in the current country (e.g. warning triangle, hazard lights, etc.);
- in the event of a wheel change on a slope or on unsurfaced roads, put any object as stop under the wheels;
- take the tool bag from under the passenger seat.

The container includes these tools:

- (A) - tow hook

- (B) - rod for spanner
- (C) - bolt spanner
- (D) - jack
- (E) - extension for spanner
- (F) - screwdriver grip
- (G) - screwdriver bit

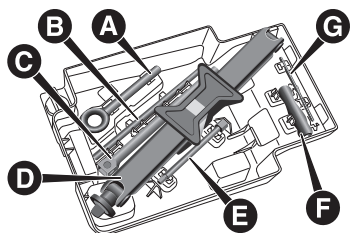

292

F1A0420

- ❑ if the tool container is not provided, for special trim versions, a bag containing the above tools may be provided;
- ❑ for versions with alloy rims, remove the press-fitted hub cap;
- ❑ take the extension for spanner, the bolt spanner and the rod for spanner from the tool container;
- ❑ with the tools assembled correctly, loosen the fixing bolts for the wheel to be changed by one turn;
- ❑ turn the ring nut to partly extend the jack;
- ❑ position the jack at the lifting support nearest the wheel to be replaced, at

the points shown in fig. 291. For short wheelbase versions with retractable footboard, the jack must be positioned at the lift point shown in fig. 293 aligned (45°) so that it does not interfere with the retractable footboard;

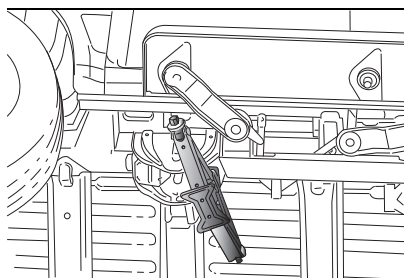

293

F1A0169

- ❑ warn anybody nearby that the vehicle is about to be lifted. They must stay clear and not touch the vehicle until it is back on the ground;
- ❑ for versions equipped with self-levelling pneumatic suspension, before using the jack to raise the vehicle, press the buttons (A) and (B) fig. 294 simultaneously for at least 5 seconds. The operating mode for raising the vehicle is activated: the LEDs on the buttons come on constantly. To exit this mode, press buttons (A) and (B) simultaneously for another 5 seconds; both LEDs on the buttons will go out and full system operation will be restored. This mode deactivates

automatically when the speed of approx. 5 km/h is exceeded.

⚠ 197

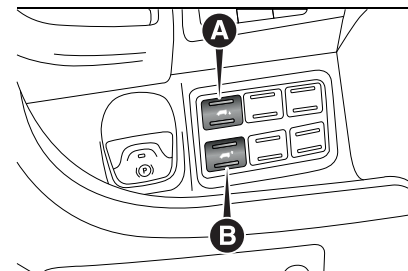

294

F1A0634

- ❑ lift the vehicle.
- After lifting the vehicle:
- ❑ for all versions, access the rear right wheel arch, operate the screw (A) fig. 295 on the spare wheel retaining device, using the supplied wrench assembled correctly with the dedicated extension (B) fig. 295;
- ❑ turn the tool anticlockwise fig. 296 to allow the spare wheel to descend;
- ❑ continue turning anticlockwise until the stop point, indicated by the stiffening of the manoeuvre or a click from the clutch present in the device;

⚠ 198) 199)



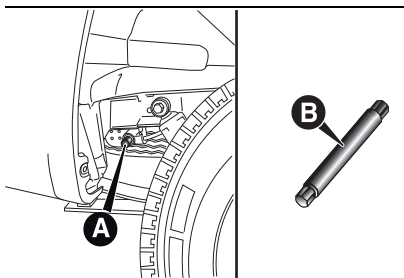

295

F1A0174

□ after unwinding the whole cable of the spare wheel lifting device, remove the wheel from the vehicle;

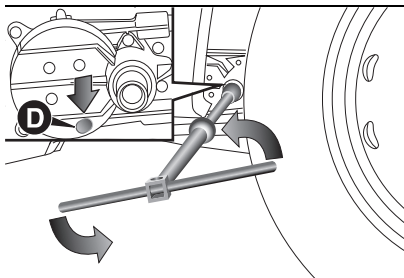

296

F1A0421

□ undo the retaining knob (D) fig. 297 and free the wheel by sliding out the support (E);

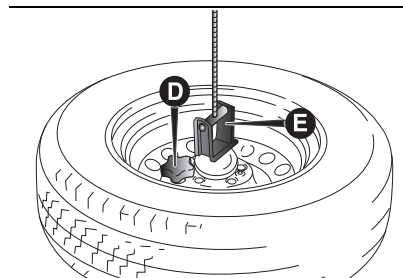

297

F1A0174

□ with the tools assembled, undo the bolts fig. 298 fully and remove the wheel;

□ fit the spare wheel, lining up the holes (G) fig. 299 with the corresponding pins H. While fitting the spare wheel, make sure that the mating surfaces are clean and free of impurities that could later cause the fixing bolts to come loose;

□ screw in the 5 fastening bolts;  
 □ assemble the tools to tighten the bolts fully, passing alternately from one bolt to the diagonally opposite one, following the scheme shown in fig. 299;  
 □ use the wheel removal wrench to lower the vehicle and remove the jack.

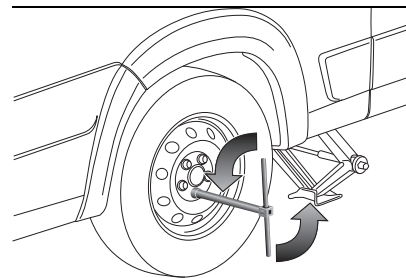

298

F1A0422

At the end of the operation:

□ take the replaced wheel, reattach it to the support (E) fig. 297 and tighten the knob (D);

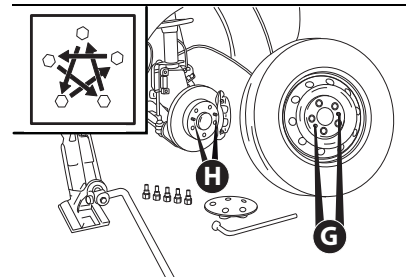

299

F1A0176

□ fit the assembled tool fig. 296 complete with extension (B)fig. 295 on the screw (A)fig. 295 of the spare wheel housing manoeuvring device and turn clockwise to lift the spare wheel back up until it is fully supported in its housing beneath the floor pan. Check

that the notch ( D )fig. 296indicating that the device is coupled appears in the window.



200)

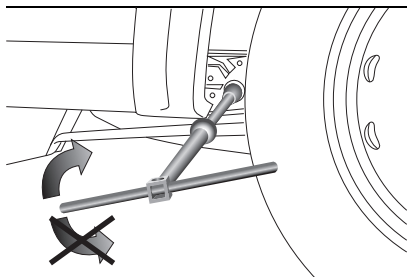

300

F1A0430

For vehicles with alloy rims, proceed as follows:

- ❑ carry out the above described operations for changing the wheel until loading the punctured wheel on the spare wheel lifting device;
- ❑ take the kit from the tool bag, located in the glove compartment;
- ❑ the kit includes one bracket, three special screws and one Allen spanner, 10 size;
- ❑ go to the rear side of the vehicle where the spare wheel is located;
- ❑ make sure that all of the cable for the spare wheel lifting device has been unrolled, grip the bell and position it inside the circular bracket fig. 301;



301

F1A0424

- ❑ tighten the knob onto the screw to secure the bracket fig. 302;

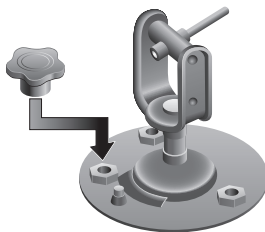

302

F1A0425

- ❑ rest the bracket on the inside of the alloy rim fig. 303;

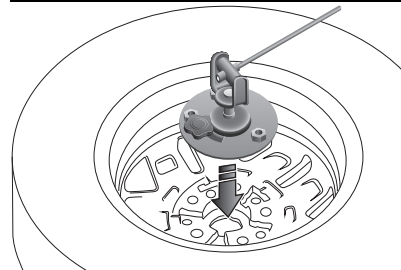

303

F1A0426

- ❑ use the Allen key to tighten the three special screws on the nuts of the bracket fig. 304 and secure the rim;

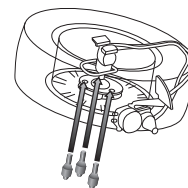

304

F1A0385

- ❑ fit the assembled tool fig. 296 complete with extension ( B )fig. 295 on the screw ( A )fig. 295 of the spare wheel housing manoeuvring device and turn clockwise to lift the spare wheel back up until it is fully supported in its housing beneath the floor pan. Check that the notch ( D )fig. 296indicating that



the device is coupled appears in the window.

❑ check that the position of the replaced wheel under the platform is correct (the lifting system is equipped with a clutch to limit the end of the stroke, incorrect positioning may jeopardise safety);

❑ place the removal tools back in the tool bag / compartment;

❑ place the tool box / compartment in its housing under the passenger seat.

 201) 202)



### IMPORTANT

**191)** Use your hazard lights, warning triangle, etc to show that your vehicle is stationary. Passengers should get out of the vehicle, particularly if it is heavily loaded, and wait for the wheel to be changed away from the traffic. Engage the parking brake. In the event of a wheel change on a slope or on unsurfaced roads, put any object as stop under the wheels.

**192)** The spare wheel supplied (for versions/markets, where provided) is specific for your vehicle. Therefore, it must not be used on other models. Do not use spare wheels of other models on your vehicle. The wheel bolts are specific for your vehicle: do not use them on different models and do not use bolts from other models on your vehicle.

**193)** Repair and refit the standard wheel as soon as possible. Do not apply grease to the bolt threads before fitting: they could come unscrewed.

**194)** Use the jack only to replace wheels on the vehicle with which it is supplied or on other cars of the same model. Never use the jack for other purposes, such as lifting other vehicle models. Never use the jack to carry out repairs under the vehicle. Incorrect positioning of the jack may cause the lifted vehicle to fall. Do not use the jack for loads higher than the one shown on its label.

**195)** Never tamper with the inflation valve. Never introduce tools of any kind between rim and tyre. Check the tyre and spare wheel pressure regularly, referring to the values shown in the "Technical specifications" section

**196)** No tools other than the crank provided should be used with the spare wheel lifting device; it should be operated by hand only.

**197)** On versions equipped with self-levelling air suspension, never introduce the head or hands in the wheel arch. The vehicle could raise or lower automatically depending on possible load or temperature changes.

**198)** The device should only be operated by hand, without using any type of tool other than the crank provided like pneumatic or electrical screwdrivers.

**199)** The moving components of the jack (screws and joints) can also cause injuries: avoid touching them. If you come into contact with lubricating grease, clean yourself thoroughly.

**200)** At the end of the operation of raising/locking the spare wheel, after having checked the correct positioning of the wheel under the platform (yellow notch inside the window on the device), the spanner must be extracted, taking care not to turn it in the wrong direction (as in fig. 300) to facilitate the extraction of the spanner itself, to prevent the attachment device from being released and the wheel assembly not being securely retained.

**201)** Each time the spare wheel is moved, check that it is correctly positioned in its housing under the platform. If it is not correctly positioned, this could adversely affect safety.

**202)** The spare wheel lifting device is equipped with a clutch safety system for its own protection; this could be activated if an excessive load is applied on the manoeuvring screw.



## TYRE REPAIR KIT

(where provided)

⚠ 203) 204) 205) 206) 207) 208) 209) 210) 211) 212) 213)

214) 215) 216)

⚠ 79) 80) 81)

⚠ 4)

The vehicle may be equipped with a different Tyre Repair Kit (OPT1 kit or OPT2 kit), according to the version. The Tyre Repair Kit is located in the right door, inside a specific container.

### PRELIMINARY OPERATIONS

Proceed as follows:

- ❑ stop the vehicle in a position that is not dangerous for oncoming traffic where you can carry out the procedure safely. The car must be stopped in a lay-by, car park or parking or service area, and the ground must be as level as possible and sufficiently compact;
- ❑ switch off the engine, switch on the hazard warning lights, apply the electric parking brake and set the gear lever to "P" (Park) (automatic transmission versions), or engage 1st gear if uphill or reverse gear if downhill (manual transmission versions);
- ❑ steer the wheels completely;
- ❑ when parked on a steep slope, place a wedge or stone behind the wheels;
- ❑ before getting out of the vehicle, put on the reflective safety jacket (if required by the regulations in force). In

any case, follow the road safety laws in force in the country where you are driving;

- ❑ make sure that any passengers get out of the vehicle and go to a safe place where they will not obstruct traffic or be exposed to the risk of injury. In the event of a puncture, change the tyre in accordance with the laws of the country in which you are travelling.

### OPT1 KIT DESCRIPTION

The Tyre Repair Kit consists of:

- ❑ a canister (A) fig. 305 of sealant, with filling : tube (B);
- ❑ a compressor (D) complete with pressure gauge, fittings and an adhesive label (C) with the words "Max. 80 km/h", to be attached in a position easily visible to the driver (e.g. on the dashboard) after repairing the tyre;
- ❑ some adaptors, for inflating different elements.

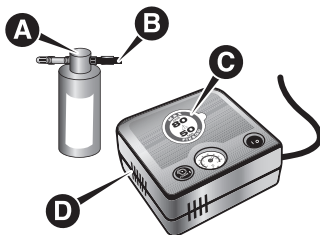

305

F1A9040

### Repair procedure

Proceed as follows:

- ❑ put on the gloves, connect the tube (E) fig. 306 to the spray can (A) using the connector (F). Unscrew the tyre valve cap and screw the filler pipe ring nut (B) onto the tyre valve;
- ❑ make sure that switch (G) fig. 307 of the compressor (D) is in "0" (off) position;
- ❑ insert the plug into the socket in the boot and then start the engine;

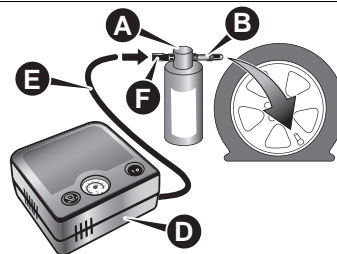

306

F1A9041

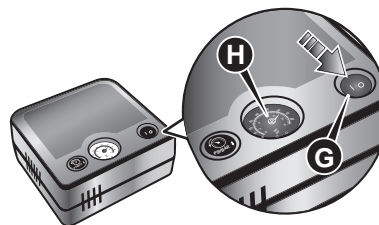

307

F1A9042



- ❑ switch on the compressor by turning the switch (G) fig. 307 to the "I" (on) position;
- ❑ Inflate the tyre to a pressure prescribed in this handbook. In order to obtain a more precise reading, check the pressure value on pressure gauge (H) fig. 307 with the compressor off;
- ❑ If the pressure of at least 1.8 bar is not reached within 15 minutes, disconnect the kit and move the vehicle a few metres to allow the sealing fluid to reach the hole in the tyre tread. Connect the compressor and restore the pressure using the hose (E) fig. 306. If a pressure of at least 1.8 bar is not reached within 15 minutes, the tyre is too badly damaged. Do not continue driving and contact a Fiat Dealership;
- ❑ after driving about 8 km, stop, apply the parking brake, check the pressure again and restore it if it exceeds 1.8 bar using the hose (E) fig. 306 and drive to a Fiat Dealership;
- ❑ instead, if the measured pressure is lower than 1.8 bar, the tyre is too damaged to be repaired. Do not continue driving and contact a Fiat Dealership.

**WARNING** Only use original tyre repair canisters, which can be purchased at a Fiat Dealership.

**WARNING** The kit must be used with the engine running for the entire tyre repair process.

### OPT2 KIT DESCRIPTION

The Fix&Go tyre repair kit contains fig. 308:

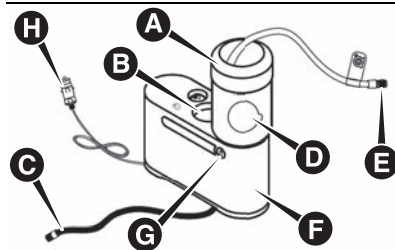

308

F1A0743

- ❑ a canister (A) of liquid sealant, complete with clear filler hose (E); black pressure top-up hose (C); sticker (D) marked max. 80 km/h to be affixed in a position in clear view of the driver (on the dashboard) after the tyre has been repaired;
- ❑ a compressor (F) provided with an electrical connector (H);
- ❑ a pair of protective gloves located in the spray can compartment.

### Repair procedure

Proceed as follows:

- ❑ stop the vehicle in a position that is not dangerous for oncoming traffic where you can change the wheel;

- ❑ stop the engine, apply the parking brake and engage 1<sup>st</sup> or reverse gear;
- ❑ before getting out of the vehicle, put on the reflective safety jacket (if required by the regulations in force). In any case, follow the road safety laws in force in the country where you are driving;
- ❑ insert the cartridge (A) containing the sealant into the corresponding compressor compartment (F) and press it down hard until you feel the locking mechanism click. Detach the speed limit sticker (D) and apply it in a clearly visible position;
- ❑ insert the cartridge (A) containing the sealant into the corresponding compressor compartment (F) and press it down hard until you feel the locking mechanism click. Detach the speed limit sticker (D) and apply it in a clearly visible position;
- ❑ wear the gloves;
- ❑ remove the cap from the tyre valve and connect and screw the transparent tube of the sealing fluid (E) onto the valve. Make sure that the ON/OFF button is in the OFF position.

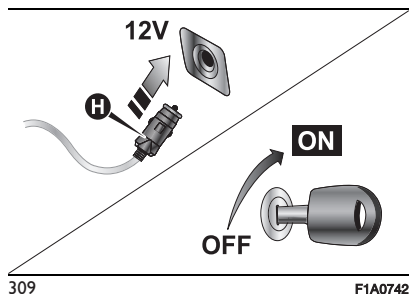

□ insert the electrical connector (H) fig. 309 in the 12 V power socket of the vehicle and start the engine;

□ operate the compressor by pressing the ON/OFF button (ON position) fig. 308. When the pressure gauge (B) reaches the recommended pressure (see the “Wheels” chapter in the “Technical Specifications” section), stop the compressor by pressing the ON/OFF button again;

□ disconnect the cartridge (A) from the compressor, by pressing the release button (G) and lifting the cartridge upwards.

If the pressure gauge (B) fig. 308 indicates a pressure lower than 3 bar 15 minutes after starting the compressor, switch off the compressor, disconnect the sealing fluid tube (E) from the tyre valve and remove the cartridge (A) from the compressor.

Move the vehicle approximately 10 metres to distribute the sealant. Stop the vehicle safely, operate the parking brake and restore pressure using the black inflation pipe (C) fig. 308 to reach the required pressure. If the pressure is still lower than 3 bar 15 minutes after switching on, do not resume driving but contact a Fiat Dealership. After driving for about 8 km / 5 miles, stop the vehicle in a safe and suitable area, and engage the parking brake. Take the compressor and restore pressure using the black inflation tube (C).

If the pressure reading is higher than 3 bar, restore the pressure and drive with great care to the nearest Fiat Dealership.

### Inflation procedure

Proceed as follows:

□ stop the vehicle safely as described above, and engage the parking brake;

□ extract the black inflation tube and screw it firmly onto the tyre valve. Then follow the instructions given above.

### Cartridge replacement

Only use original cartridges, which can be purchased from the Fiat Dealership.



## IMPORTANT

**203) WARNING:** The kit must only be used for tyre repair.

**204) ATTENTION:** Do not exceed 80 km/h. Avoid sudden acceleration or braking. The Tyre Repair Kit provides a temporary repair, so the tyre must be examined and repaired by a specialist as soon as possible. Before using the Tyre Repair Kit, ensure that the tyre is not damaged excessively and that the rim is in good condition, otherwise do not use it and call roadside assistance. Do not remove foreign bodies from the tyre.

**205) Punctures on the sides of the tyre may not be repaired. Do not use the Tyre Repair kit if the tyre was damaged as a result of being used when underinflated.**

**206) Wear the protective gloves provided with the Tyre Repair kit.**

**207) Apply the sticker where it can be easily seen by the driver as a reminder that the tyre has been treated with the Tyre Repair Kit. Drive carefully, particularly on bends.**

**208) As required by current regulations, the information on chemical substances for the protection of human health and the environment and on the safe use of the sealing fluid are on the packaging label. Compliance with the indications on the label is an essential condition to ensure the safety and the effectiveness of the product. Remember to carefully read the label before use; the user of the product is responsible for any damages caused by improper use. The sealing fluid has an expiration date. Replace the bottle if the sealant has expired.**



**209)** Repairs are not possible in the case of damage to the wheel rim (bad groove distortion causing air loss). Do not remove the foreign body (screws or nails) from the tyre.

**210)** The Tyre Repair Kit is not suitable for definitive repairs, so the repaired tyres may only be used temporarily. The Tyre Repair Kit provide a temporary repair, therefore the tyre must be examined and repaired by a specialist as soon as possible.

**211)** Use your hazard warning lights, warning triangle, etc. to show that your vehicle is stationary. Passengers should get out of the vehicle, particularly if it is heavily loaded, and wait for the wheel to be changed away from the traffic. On gradients or on unsurfaced roads, chock the wheels with the chocks provided.

**212)** If the pressure falls below 1.8 bar, do not drive any further: the Tire Repair Kit cannot guarantee proper seal because the tyre is too damaged. Contact a Fiat Dealership.

**213)** Carefully read the cartridge label before use and avoid improper use. The kit should be used by adults and cannot be used by children.

**214)** You must always indicate that the tyre was repaired using the Tyre Repair Kit. Give the booklet or the cartridge to the technicians who will be handling the tyre that was treated using the Tire Repair Kit.

**215)** Do not let the compressor turned on for longer than 20 consecutive minutes - overheating hazard

**216)** Use the kit only in case of a punctured tyre.



## WARNING

**79)** The sealant fluid is effective within a temperature range of  $-30^{\circ}\text{C}$  to  $+50^{\circ}\text{C}$ . The sealant fluid has an expiry date and must be replaced periodically.

**80)** The surface of the tube may be hot.

**81)** In the event of a puncture caused by foreign bodies, the kit may be used to repair tyres showing damage on the tyre tread up to max. 6 mm diameter.



## WARNING

**4)** Dispose of the bottle and the sealant liquid properly. Have them disposed of in compliance with national and local regulations.

## JUMP STARTING

Go to a Fiat Dealership immediately if warning light  comes on steady on the instrument panel.

### STARTING WITH AUXILIARY BATTERY

If the battery is flat, it is possible to start the engine using an auxiliary battery with the same capacity or a little higher than the flat one.

It is advisable to contact a Fiat Dealership to check/replace the battery.



Proceed as follows to start the car:

- lift the flap (A) fig. 310 to access the positive battery terminal connection.
- connect the positive terminals (+ mark near the terminal) of the two batteries using a suitable lead;
- use a second lead to connect the negative terminal (-) of the auxiliary battery to the earth point as shown in fig. 311;
- start the engine;
- when the engine has been started, remove the cables reversing the order above.

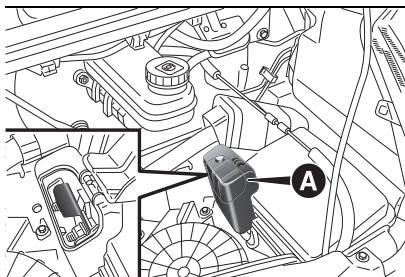

310

F1A0351

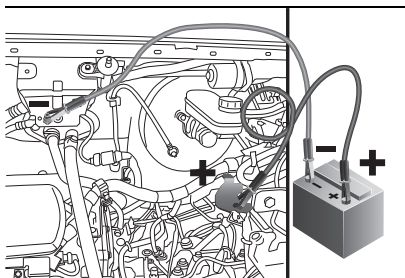

311

F1A0352

If after a few attempts the engine does not start, do not persist but contact the nearest Fiat Dealership.

**WARNING** Do not directly connect the negative terminals of the two batteries: sparks could ignite explosive gas released from the battery. If the auxiliary battery is installed on another vehicle, avoid any metal parts on the latter and the vehicle with the flat

battery from accidentally coming into contact.

## BUMP STARTING

Never bump start the motor by pushing, towing or driving downhill. This could cause fuel to flow into the catalytic converter and damage it beyond repair.



### IMPORTANT

**217)** *This starting procedure must be performed by expert personnel because incorrect actions could cause electrical discharge of considerable intensity. Furthermore, battery fluid is poisonous and corrosive: avoid contact with skin and eyes. Keep naked flames and lighted cigarettes away from the battery and do not cause sparks.*

## RECHARGING THE BATTERY

**WARNING** The battery recharging procedure is given as information only. To carry out this operation contact a Fiat Dealership.

**WARNING** After setting the ignition device to STOP and having closed the driver side door, wait at least one minute before disconnecting the electrical supply from the battery. When reconnecting the electrical supply to the battery, make sure that the ignition device is in the STOP position and the driver's door is closed.

**WARNING** Charging should be slow at a low ampere rating for approximately 24 hours. Regardless of the duration of the operation, it is always recommended to disconnect the battery from the device as soon as charging is complete to avoid potential damage.

**WARNING** The cables of the electrical system must be correctly reconnected to the battery, i.e. the positive cable (+) to the positive terminal and the negative cable (-) to the negative terminal. The battery terminals are marked with the positive (+) and



negative (-) symbols, and are shown on the battery cover. The battery terminals must also be corrosion-free and firmly secured to the terminals. If a "quick-type" battery charger is used with the battery fitted on the vehicle, disconnect both battery leads before connecting it. Do not use a "quick-type" battery charger to provide the starting voltage.



### VERSIONS WITHOUT START&STOP SYSTEM

To charge, proceed as follows:

- ❑ disconnect the terminal from the negative battery pole;
- ❑ connect the charger cables to the battery terminals, observing the polarity;
- ❑ turn on the battery charger;
- ❑ when it is recharged, turn the charger off before disconnecting it from the battery;
- ❑ reconnect the terminal to the negative battery pole.

### VERSIONS WITH START&STOP SYSTEM

To charge, proceed as follows:

- ❑ disconnect the connector (A) (pressing the button (B)) from the sensor (C) monitoring the battery conditions, on the negative pole (D) of the battery;

- ❑ connect the positive cable of the battery charger to the positive battery terminal (E) and the negative cable (F) to sensor terminal as shown in fig. 312;
- ❑ turn on the charger;
- ❑ at the end of the charging process, switch the battery charger off;
- ❑ after having disconnected the battery charger, reconnect connector (A) to the sensor (C) as shown fig. 312.

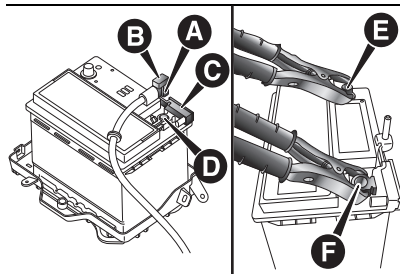

312

F1A0219

### ! IMPORTANT

**218)** *Battery fluid is poisonous and corrosive: avoid contact with your skin and eyes. The battery should be charged in a well ventilated place, away from naked flames or possible sources of sparks: danger of explosion and fire.*

**219)** *Do not attempt to recharge a frozen battery: first it must be thawed, otherwise there is a risk of explosion. If freezing has occurred, the battery should be checked by specialised technicians to make sure*

*that the internal elements are not damaged and that the body is not cracked, with the risk of leaking poisonous and corrosive acid.*

## ADDITIONAL HEATER FUEL CUT-OFF SWITCH

The vehicle is fitted with a safety switch that trips to cut off the fuel supply to the additional heater in the event of a collision.



### Reactivating the additional heater fuel cut-off switch

Press the button to reactivate the fuel cut-off switch of the additional heater (A) fig. 313.

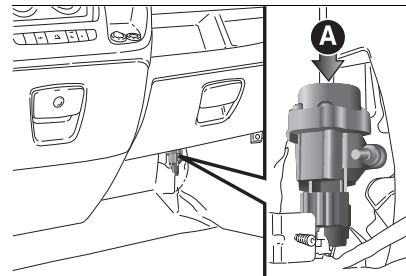

313

F1A0086





## IMPORTANT

**220)** If, after a crash, you smell fuel or notice leaks from the fuel supply system, do not reset the switch to avoid fire risk.

**221)** Before reactivating the fuel cut-off switch, carefully check for fuel leaks or damage to the vehicle electrical devices (e.g. headlights).

## FUEL CUT-OFF SYSTEM

This intervenes in the case of a collision causing:

- the interruption of the fuel supply with the engine consequently cutting out;
- automatic unlocking of the doors;
- turning on the lights inside the car;
- deactivation of climate control system ventilation;
- switching on the emergency lights (to disable the lights, run the "reset" procedure as shown below).

On some versions, the intervention of the system is indicated by a message shown on the display. In the same way, a dedicated message on the display warns the driver if system operation is compromised.

WARNING Check carefully for fuel leaks, for instance in the engine

compartment, under the vehicle or near the tank area.

After a collision, bring the ignition device to STOP to prevent the battery from running down.

Reset procedure In case of a minor collision, simply turn the key to STOP and then restart. In the event of a major collision, you must call for assistance, as restarting the vehicle is not possible.

## AUTOMATIC TRANSMISSION GEAR LEVER RELEASE

In the event of a failure, to move the gear lever from P (Park), proceed as follows:

- switch off the engine;
- engage the parking brake;
- working carefully in the point indicated by the arrow, fig. 314, remove the gaiter lifting it upwards;

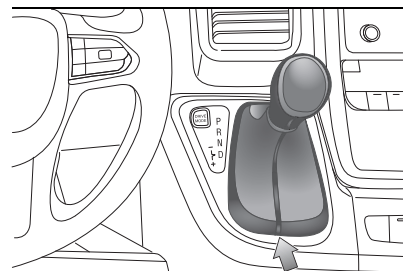

314

F1A0707

- depress the brake pedal and keep it fully depressed;
- insert the supplied screwdriver perpendicular into the release hole in the rear right corner of the gear selector unit (fig. 315) and press the release lever and the button on the knob at the same time;

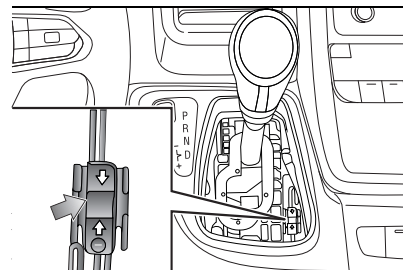

315

F1A0708

- move the gear lever to N (Neutral);
- refit the gear lever gaiter correctly;



- start the engine.

## IGNITION KEY EMERGENCY REMOVAL

(versions with automatic transmission)



The ignition key (for versions with key without remote control) can be removed only if the gear lever is in position P (Park).

If the vehicle battery is flat and the ignition key is engaged, the latter is locked in position.

Follow these steps to extract the key fob manually:

- stop the vehicle in safe conditions, engage a gear and the parking brake;
- using the key (A) fig. 316 provided (located in the container with the handbook), undo the fixing screws (B) fig. 317 of the lower trim;

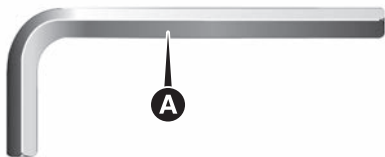

316

F1A0477

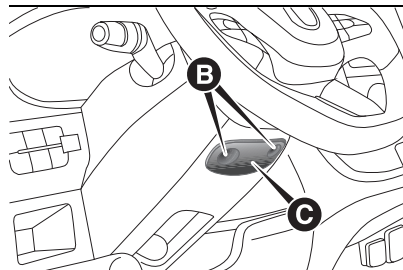

317

F1A0787

- remove the lower steering column trim (C) fig. 317 releasing it from its housing;
- pull tab (D) fig. 318 downwards using one hand and with the other one remove the key, sliding it outwards;

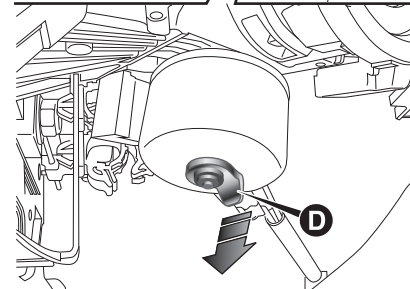
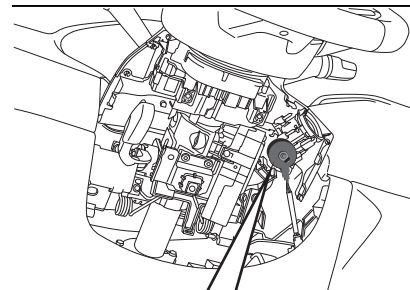

318

F1A0469

- once the key has been removed, refit the lower trim (C) fig. 317, make sure it locks correctly and fully tighten the fixing screws (B).



### WARNING

**82)** It is advisable to contact a Fiat Dealership to have the refitting procedure carried out. If you would like to proceed autonomously, special attention must be paid to the correct coupling of the



retaining clips. Otherwise, noise might be heard due to an incorrect fastening of the lower cover with the upper cover.

## TOWING THE VEHICLE

⚠ 222) 223) 224) 225) 226) 227) 228) 229) 230)

The vehicle is equipped with two rings for attaching the tow hook.

The front ring is located in the tool box beneath the passenger side seat.

On versions with Fix&Go kit and without spare wheel, the tool box is available only on request for versions/markets where provided.

In the absence of the tool box the vehicle front tow hook is housed in the on-board documentation container,

together with the Owner Handbook.

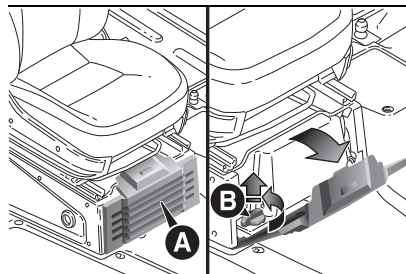

319

F1A0221

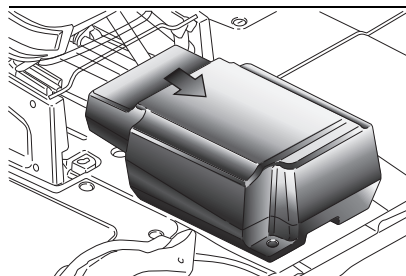

320

F1A0222

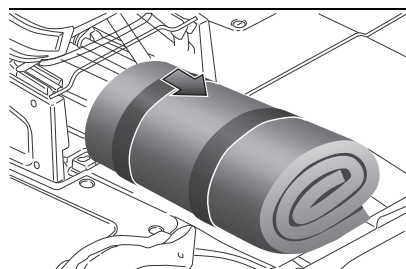

321

F1A0344

To use it, proceed as follows:

❑ Open the flap (A) and remove it as shown in fig. 319;

❑ turn the lock knob (B) fig. 319 anticlockwise and remove it to allow the compartment fig. 320 to be removed;

❑ take the screwdriver provided from the box and prise up at the point shown to raise the cap (C) fig. 322;

❑ take the tow ring (D) from the box and screw onto the threaded pin fig. 322.

The rear ring (B) fig. 323 is located at the point shown in the figure.

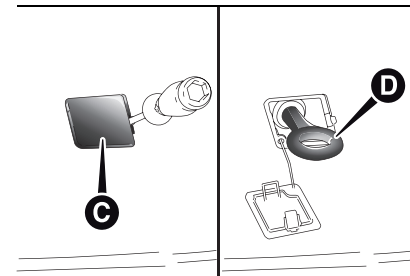

322

F1A0223

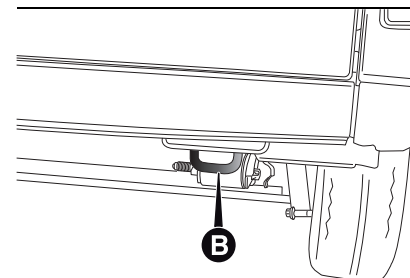

323

F1A0224

## VERSIONS WITH AUTOMATIC TRANSMISSION

Vehicles with AT9 automatic transmission cannot be towed.



**IMPORTANT**

**222)** *Screw on the tow ring and check that it stops at the end of travel position.*

**223)** *Before towing, switch off the steering lock (see the "Ignition device" chapter in the "Knowing your vehicle" section).*

**224)** *The power brakes and power steering will not operate while the vehicle is being towed. More effort on the brake pedal and steering wheel will therefore be required.*

**225)** *Do not use flexible cables when towing and avoid jerky movements. During towing operations, make sure that the fastened joint does not damage adjoining components.*

**226)** *When towing the vehicle, it is necessary to obey specific road regulations which relate both to the towing device as well as to the behaviour to adopt on the road.*

**227)** *Do not start the engine whilst the vehicle is being towed.*

**228)** *Towing must be made exclusively on roads/streets; the device must not be used to recover the vehicle if it got off the road.*

**229)** *Towing must not be used in order to get past significant obstacles on the road (e.g. heaps of snow or material on the road surface).*

**230)** *Towing must take place with the two vehicles (one towing, the other towed) aligned as much as possible. Towing by roadside assistance vehicles, too, must take place with the two vehicles aligned as much as possible.*

# SERVICING AND MAINTENANCE

*Correct maintenance permits the performance of the vehicle to be maintained over time, as well as limited running costs and safeguarding the efficiency of the safety systems.*

*This section explains how.*

|                                    |     |
|------------------------------------|-----|
| SCHEDULED SERVICING .....          | 254 |
| PERIODIC CHECKS .....              | 254 |
| DEMANDING VEHICLE USE .....        | 254 |
| SERVICE SCHEDULE .....             | 255 |
| CHECKING LEVELS .....              | 258 |
| AIR CLEANER/POLLEN<br>FILTER ..... | 262 |
| BATTERY .....                      | 263 |
| WINDSCREEN WIPER .....             | 264 |
| LIFTING THE VEHICLE .....          | 265 |
| WHEELS AND TYRES .....             | 266 |
| SNOW TYRES .....                   | 267 |
| SNOW CHAINS .....                  | 267 |
| BODYWORK .....                     | 268 |
| INTERIOR .....                     | 270 |
| RUBBER HOSES .....                 | 270 |



## SCHEDULED SERVICING

---

Correct servicing is crucial for guaranteeing a long life for the vehicle under the best conditions.

For this reason, Fiat Professional has planned a series of checks and services at fixed distance and/or time intervals, as described in the Service Schedule.

If during each operation, in addition to the ones scheduled, the need arises for further replacements or repairs, these may only be carried out with the express agreement of the Customer. It may sometimes be appropriate to reduce the frequency of some of the operations described in the service schedule, in particular:

- carrying out the additional checks suggested below to ensure the optimal state of efficiency of the vehicle;
- in case of heavy use conditions (the main ones described below, e.g. towing trailers).

**WARNING** The scheduled service deadlines are set out by the Manufacturer. Failure to have them carried out may invalidate the New Vehicle Limited Warranty. We advise sharing any doubts regarding the proper operation of the vehicle with

your Fiat Professional Dealership, before waiting for the next scheduled service deadline.

## PERIODIC CHECKS

---

Every 1000 km or before long journeys, check and, if necessary, top up:

- engine coolant level;
- brake fluid level;
- AdBlue® (UREA) Diesel emissions additive (for versions/markets, where provided);
- windscreen washer fluid level;
- tyre inflation pressure and condition;
- operation of lighting system (headlights, direction indicators, hazard warning lights, etc.);
- operation of windscreen washer/wiper system and positioning/wear of windscreen/rear window wiper blades.

Check engine oil level and top up every 3000 kilometres, if required.

## DEMANDING VEHICLE USE

---

If the vehicle is mostly used in one of the following conditions:

- towing a trailer or caravan;
  - dusty roads;
  - short, repeated journeys (less than 7-8 km) at sub-zero external temperatures;
  - engine often idling or driving long distances at low speeds or long periods of inactivity;
- the following checks must be carried out more often than may be indicated in the Service Schedule:
- check front disc brake pad condition and wear;
  - check cleanliness of bonnet and boot locks, cleanliness and lubrication of linkage;
  - visually inspect conditions of: engine, transmission, transmission, pipes and hoses (exhaust/fuel system/brakes) and rubber elements (gaiters/sleeves/bushes, etc.);
  - check battery charge and battery fluid level (electrolyte);
  - visually inspect conditions of the accessory drive belts;
  - check and, if necessary, change engine oil and replace oil filter;
  - check and, if necessary, replace passenger compartment filter.

# SERVICE SCHEDULE

| Thousands of miles  | 30 | 60 | 90  | 120 | 150 |
|---|----|----|-----|-----|-----|
| Thousands of kilometres   | 48 | 96 | 144 | 192 | 240 |
| Years   | 2  | 4  | 6   | 8   | 10  |
| Check battery charge status and possibly recharge   | ●  | ●  | ●   | ●   | ●   |
| Check tyre condition/wear and adjust pressure, if necessary; check the expiry date of the "Fix&Go Automatic" repair kit (for versions/markets, where provided)                      | ●  | ●  | ●   | ●   | ●   |
| Check operation of lighting system (headlights, direction indicators, hazard warning lights, boot, passenger compartment, glove compartment, instrument panel warning lights, etc.) | ●  | ●  | ●   | ●   | ●   |
| Check operation of the windscreen wiper/washer system and adjust nozzles, if necessary  | ●  | ●  | ●   | ●   | ●   |
| Check windscreen/rearscreen wiper blade position/wear (for markets/versions, where provided)  | ●  | ●  | ●   | ●   | ●   |
| Check cleanliness of bonnet and luggage compartment locks, cleanliness and lubrication of linkage   | ●  | ●  | ●   | ●   | ●   |
| Visually inspect condition of: exterior bodywork, underbody protection, pipes and hoses (exhaust, fuel system, brakes), rubber elements (gaiters, sleeves, bushes, etc.)            | ●  | ●  | ●   | ●   | ●   |
| Check condition and wear of front disc brake pads and operation of pad wear indicator   | ●  | ●  | ●   | ●   | ●   |
| Check condition and wear of rear disc brake pads and operation of pad wear indicator (for versions/markets where provided)  | ●  | ●  | ●   | ●   | ●   |
| Check and, if necessary, top up the fluid levels in the engine compartment (heat engine coolant, brakes, windscreen washer, etc.) (1)   | ●  | ●  | ●   | ●   | ●   |
| Visually inspect the condition and tensioning of the accessory drive belt(s)  |    | ●  |     | ●   |     |



| Thousands of miles   | 30  | 60 | 90  | 120 | 150 |
|--|-----|----|-----|-----|-----|
| Thousands of kilometres  | 48  | 96 | 144 | 192 | 240 |
| Years  | 2   | 4  | 6   | 8   | 10  |
| Inspect the conditions of toothed timing drive belt  |     | ●  |     | ●   |     |
| Check parking brake lever travel and adjust, if necessary  | ●   | ●  | ●   | ●   | ●   |
| Check exhaust emissions/smokiness  | ●   | ●  | ●   | ●   | ●   |
| Use the diagnosis socket to check fuel/engine management system operation and engine oil decay (the latter for versions/markets, where provided) | ●   | ●  | ●   | ●   | ●   |
| Check cleanliness of sliding side door lower guides for versions with S.S.D.   | ●   | ●  | ●   | ●   | ●   |
| Replace fuel filter cartridge  | ●   | ●  | ●   | ●   | ●   |
| Replace accessory drive belt/s   | (5) |    |     |     |     |
| Replace toothed timing drive belt  | (5) |    |     |     |     |
| Replace air cleaner cartridge (2)  | ●   | ●  | ●   | ●   | ●   |
| Change engine oil and replace oil filter   | (3) |    |     |     |     |
| Change the brake fluid   | (4) |    |     |     |     |
| Replace the passenger compartment filter   | ●   | ●  | ●   | ●   | ●   |

|                                      |     |    |     |     |     |
|--------------------------------------|-----|----|-----|-----|-----|
| Thousands of miles                   | 30  | 60 | 90  | 120 | 150 |
| Thousands of kilometres              | 48  | 96 | 144 | 192 | 240 |
| Years                                | 2   | 4  | 6   | 8   | 10  |
| Replace TBM battery (where provided) | (6) |    |     |     |     |

(1) Top up using the fluids indicated in the “Fluids and lubricants” chapter of the “Technical Specifications” section and only after checking that the system is intact.

(2) If the vehicle is used in dusty areas, the filter must be replaced every 24,000km.

(3) The actual interval for changing the oil and replacing the engine oil filter depends on the vehicle usage conditions and is signalled by the warning light or message (if provided) on the instrument panel and must never exceed 24 months. Change engine oil and oil filter every 12 months if the vehicle is driven mainly in towns.

(4) The brake fluid replacement has to be done every two years, regardless of the mileage.

(5) The belt must be replaced every 5 years or 144,000 km. If the vehicle is used in heavy conditions (trailer towing, dusty roads, particularly harsh weather conditions, very low or very high temperatures for extended periods, urban driving, frequent/long periods of idling), the belt must be replaced every 3 years or no more than 60000 km.

(6) The system indicates when replacement of the TBM (Telematics Box Module) battery is necessary via a message on the relative display. It is to be replaced every 5 years regardless of the distance travelled.

NOTE Change automatic transmission oil (AT9) and replace oil filter every 240,000 km.



## CHECKING LEVELS

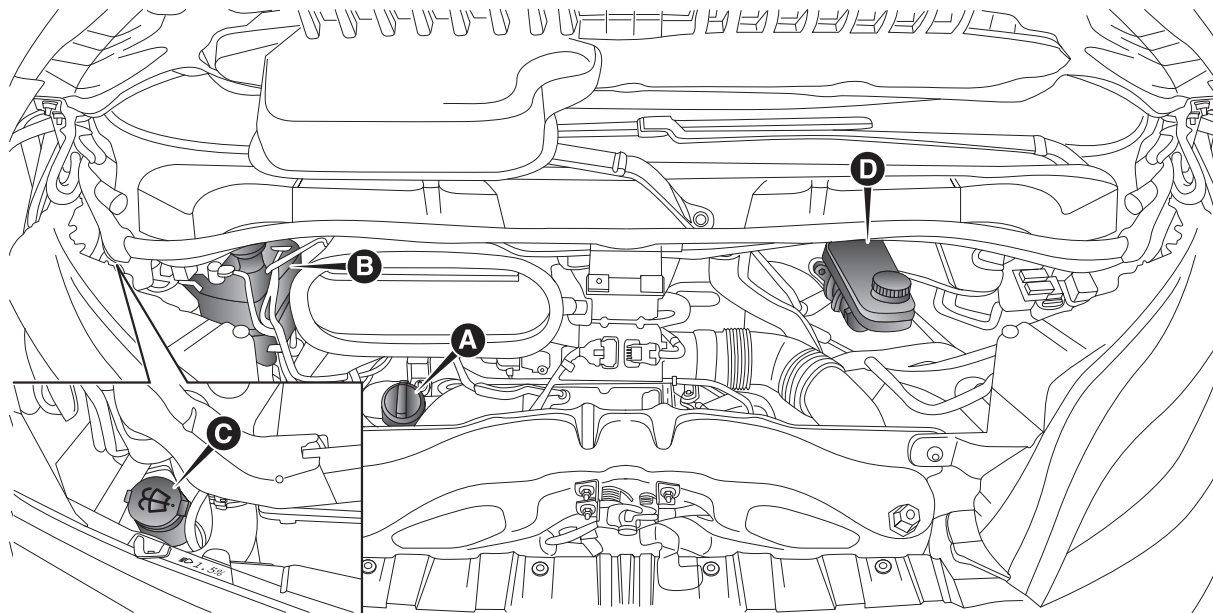

324

F1A0397

A. Engine oil filler plug B. Engine coolant C. Windscreen washer fluid D. Brake fluid

⚠ 231) 232)

⚠ 83)





## IMPORTANT

**231)** Never smoke while working in the engine compartment: inflammable gases and vapours may be present, constituting a fire risk.  
**232)** Be very careful working in the engine compartment when the engine is hot: you may get burned. Remember that the fan may start up if the engine is hot: this could injure you. Scarves, ties and other loose clothing might be pulled by moving parts.



## WARNING

**83)** When topping up, take care not to mix up the various types of fluids: they are not compatible with each other and could seriously damage the vehicle.



## ENGINE OIL



**WARNING** It is advisable to check the engine oil level indication before long journeys. The engine oil level is visible on the instrument panel display each time the engine is started.

Check on the display that the oil level is between the minimum and maximum level.

If the oil level indicator reaches the lower mark on the scale, add oil through the filler.

If the  symbol and "insufficient engine oil level" indication appears on the display, add 0.2 litres oil at a time and read again until the level reaches at least the minimum.

**WARNING** Make sure not to add too much engine oil when topping up. Engine oil in excess may damage the engine. Have your vehicle checked. Never exceed the MAX level when topping up engine oil. It is advisable to check the oil level in intermediate steps on the instrument panel display.

## Oil level indication update on display

If a top-up is needed, proceed as follows to ensure correct indication of the oil level on the display.

Proceed as follows:

□ with the vehicle on level ground, leave the engine running until it is warm (refer to the oil temperature panel) and then switch it off;

□ wait for at least 6 minutes, turn the ignition switch to ON without starting the engine and wait for 20 seconds.

*Procedure for reading the engine oil level with the engine running and idling*

Proceed as follows:

□ with the vehicle stationary, parked on level ground, leave the engine running until it is warm (refer to the oil temperature panel);

□ idle the engine and wait at least 1 minute for the correct reading.

**WARNING** If the indication is not correct after the procedure, contact a Fiat Dealership.

## Engine oil consumption

The maximum engine oil consumption is usually 400 grams every 1000 km. When the vehicle is new, the engine needs to be run in, therefore the engine oil consumption can only be

considered stabilised after the first 5,000–6,000 km.

## ENGINE COOLANT



The coolant level must be checked when the engine is cold and must range between the MIN and MAX marks on the reservoir.

If the level is to low, operate as follows:

□ to access the reservoir filler, remove the plastic cover (A) fig. 325 by turning the locking screws (B) anticlockwise;

□ slowly pour through the filler (B) - fig. 324 - the reservoir a mixture of 50% demineralised water and 50% PETRONAS LUBRICANTS PARAFLU<sup>UP</sup> until the level is close to MAX.

The mixture of 50% demineralised water and 50% PARAFLU<sup>UP</sup> protects against freezing down to -35°C.

When the vehicle is used in particularly harsh weather conditions, we recommend using a mixture of 60% PARAFLU<sup>UP</sup> and 40% demineralised water.

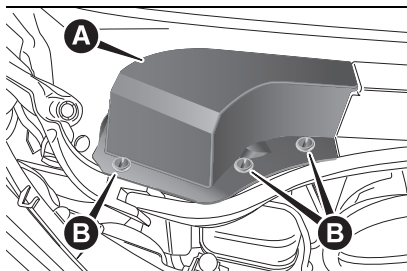

325

F1A0396

## WINDSCREEN/REAR WINDOW WASHER FLUID

234) 235)

Proceed as follows to add liquid:

- remove the (C) - fig. 324, pulling the retaining tooth outwards;
- pull the opening of the pipe upwards to extract the telescopic funnel fig. 326.

**WARNING** To prevent the cap from being damaged and interfering with the adjacent mechanical parts, make sure that it is correctly oriented as shown in fig. 326 before opening it. Otherwise, turn it until it reaches the correct position.

Use a mixture of water and PETRONAS DURANCE SC 35, in the following concentrations: 30% PETRONAS DURANCE SC 35 and 70% water in

winter or 50% PETRONAS DURANCE SC 35 and 50% water in winter. At temperatures below -20°C, use undiluted PETRONAS DURANCE SC 35 fluid.

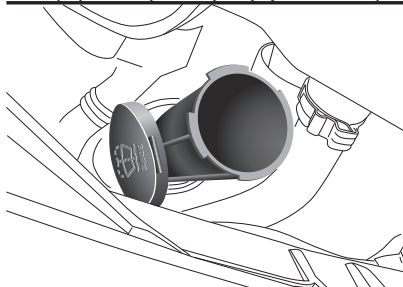
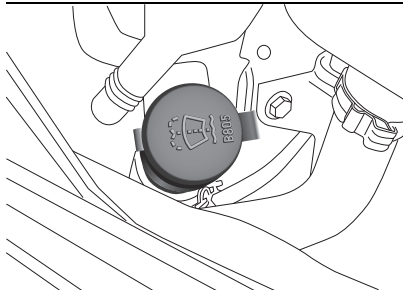

326

F1A0396

To close the cap, operate as follows:

- push the funnel fully until it locks;
- close the cap.

236)

## BRAKE FLUID

237) 238)

86)

Undo the cap (D) - fig. 324: check that the liquid contained in the reservoir is at the maximum level.

The fluid level in the reservoir must not exceed the MAX mark.

Use the brake fluid shown in the "Fluids and lubricants" table (see "Technical Specifications" section).

**NOTE** Carefully clean the cap of the reservoir and the surrounding surface.

Take great care to ensure that impurities do not enter the reservoir when the cap is opened.

Always use a funnel with a built-in filter with a mesh of 0.12 mm or less.

**WARNING** Brake fluid absorbs moisture. For this reason, if the vehicle is mainly used in areas with a high degree of atmospheric humidity, the fluid should be replaced at more frequent intervals than specified in the "Service Schedule".



### IMPORTANT

**233)** *The cooling system is pressurised. If necessary, only replace the plug with another original or the operation of the system may be adversely affected. Do not*

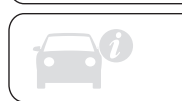

remove the reservoir plug when the engine is hot: you risk scalding yourself.

**234)** Do not travel with the windscreen washer fluid reservoir empty: the windscreen washer is essential for improving visibility.

**235)** Some commercial windscreen washer additives are flammable. The engine compartment contains hot parts which could start a fire if they come into contact.

**236)** Do not release the cap from the extension without previously extracting the system using the ring.

**237)** Brake fluid is poisonous and highly corrosive. In the event of accidental contact, immediately wash the affected parts with water and mild soap. Then rinse thoroughly. Call a doctor immediately if swallowed.

**238)** The symbol ©, on the brake fluid container indicates if a brake fluid is synthetic or mineral-based. Use of mineral type fluids will damage the special rubber seals of the braking system beyond repair.



**WARNING**

**84)** Used engine oil and replaced oil filters contain substances which are harmful to the environment. To change oil and filters, we advise you to contact a Fiat Dealership.

**85)** PARAFLU<sup>UP</sup> anti-freeze fluid is used in the cooling system. Use fluid of the same type as that contained in the cooling system for topping up. PARAFLU<sup>UP</sup> fluid cannot be mixed with any other type of fluid. If this occurs, do not start the

engine and contact your Fiat Dealership immediately.

**86)** Prevent brake fluid, which is highly corrosive, from coming into contact with painted parts. Should it happen, immediately wash with water.

**AIR CLEANER/POLLEN FILTER**

Have the air cleaner replaced by a Fiat Dealership.

**AIR CLEANER - DUSTY ROADS**

(for versions/markets, where provided)  
The air cleaner for dusty areas, except for versions with automatic transmission, is equipped with a visual filter clogging indicator device (A) fig. 327.

Therefore it is necessary to check the reading of the blockage sensor at intervals (Refer to the "Service Schedule" in the "Maintenance and care" section).

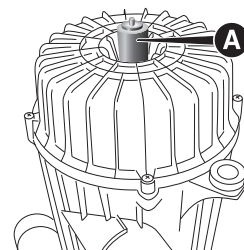

327

F1A0238

When the setting is reached the indicator (B) fig. 328 switches to red, even with the engine off. To reset the indicator, clean/replace the cartridge as on normal versions and then reset the indicator by pressing the button (C) fig. 328.

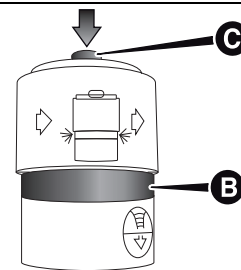

328

F1A0239

**WARNING** To blow the filter use an air jet, do not use water or liquid detergents. Since this cleaner is specific to versions designed for dusty areas, it

is advisable to contact a Fiat Dealership to change the cleaner.

## BATTERY

The battery is "limited maintenance" type: under normal conditions of use, the electrolyte does not need topping up with distilled water. It does, however, need to be checked periodically at a Fiat Dealership or by specialist personnel to make sure it is working correctly.

The battery is located inside the passenger compartment, in front of the pedals. Remove the protective cover to gain access to it.

 239) 240)

## REPLACING THE BATTERY

If required, replace the battery with an original spare part with the same specifications.

If a battery with different specifications is fitted, the service intervals given in the "Scheduled Servicing Plan" will no longer be valid.

Follow the battery manufacturer's instructions for maintenance.

 241) 242)

 87) 88)

 5)

## USEFUL ADVICE FOR EXTENDING THE LIFE OF YOUR BATTERY

To avoid draining your battery and make it last longer, observe the following instructions:

- when you park the vehicle, ensure that the doors, tailgate and bonnet are closed properly, to prevent any ceiling lights from remaining on inside the passenger's compartment;
- switch off all ceiling lights inside the vehicle: the vehicle is however equipped with a system which switches all internal lights off automatically;
- do not keep accessories (e.g. radio, hazard warning lights, etc.) switched on for a long time when the engine is not running;
- before carrying out any operation on the electrical system, disconnect the negative battery cable through the suitable terminal:
  - For versions with Start&Stop system: the procedure must be performed by disconnecting the connector (A) (pressing the button (B)) from the sensor (C) monitoring the battery conditions, on the negative pole (D) of the battery fig. 312.

- For versions without Start&Stop system: disconnect the negative terminal from the battery terminal. If the vehicle is equipped with a battery disconnection function (disconnecter), see the description of the disconnection procedure in the "Battery disconnection function (disconnecter)" chapter.

- completely tighten the battery terminals.

**WARNING** After turning the ignition key to STOP and having closed the driver side door, wait at least one minute before disconnecting the electrical supply from the battery. When reconnecting the electrical supply to the battery, make sure that the ignition key is in the STOP position and the driver's door is closed.

**WARNING** If the charge level remains under 50% for a long time, the battery is damaged by sulphation, reducing its capacity and efficiency at start-up. The battery is also more prone to the risk of freezing (at temperatures as high as -10°C). Refer to the "Prolonged vehicle inactivity" chapter in the "Starting and driving" section if the car is left parked for a long time.



If, after buying the vehicle, you want to install electrical accessories which require permanent electric supply (alarm, etc.) or accessories that in any case burden the electrical supply, contact a Fiat Dealership, whose qualified personnel, in addition to suggesting the most suitable devices from Lineaccessori MOPAR, will evaluate the overall electrical consumption, checking whether the vehicle electrical system is capable of withstanding the load required, or whether it should be integrated with a more powerful battery.

Since some of these devices continue to consume electricity even when the motor is off, they gradually run down the battery.

**WARNING** If a tachograph is fitted, if the vehicle is parked for a long period of 5 days, it is advisable to disconnect the negative battery terminal to maintain its charge. If the vehicle is equipped with a battery disconnection function (disconnecter), see the description of the disconnection procedure in the "Battery disconnection function (disconnecter)" chapter in the "Starting and driving" section.



### IMPORTANT

**239)** *Battery fluid is poisonous and corrosive. Avoid contact with skin and eyes. Keep naked flames and sources of sparks away from the battery: risk of explosion and fire.*

**240)** *Using the battery with insufficient battery fluid may irreparably damage the battery and may cause an explosion.*

**241)** *Before performing any operation on the electrical system, disconnect the negative battery cable through the suitable terminal, after having waited at least one minute from turning the ignition key to STOP.*

**242)** *Always wear appropriate goggles to protect your eyes when working on or near the conventional battery.*



### WARNING

**87)** *Incorrect installation of electric and electronic devices may cause severe damage to your vehicle. After purchasing your vehicle, if you wish to install any accessories (anti-theft, radio phone, etc.), go to a Fiat Dealership, which will suggest the most suitable devices and advise you whether a higher capacity battery needs to be installed.*

**88)** *If the vehicle will be unused for an extended period of time in extremely cold weather conditions, remove the battery and store it in a heated area to prevent it from freezing.*



### WARNING

**5)** *Batteries contain substances which are very harmful for the environment. You are recommended to go to a Fiat Dealership to have the battery replaced where the old battery will be disposed of respecting both the environment and the laws in force.*

## WINDSCREEN WIPER

### WIPER BLADES

Periodically clean the rubber part using special products; TUTELA PROFESSIONAL SC 35 is recommended.

Replace the blades if the rubber edge is deformed or worn. In any case, it is advisable to replace them approximately once a year.

A few simple precautions can reduce the possibility of damage to the blades:

- if the temperature falls below zero, make sure that ice has not frozen the rubber to the glass. Use a de-icing product to release it if required;
- remove any snow from the glass: in addition to protecting the blades, this prevents effort on the motor and overheating;
- do not operate the windscreen and rear window wipers on dry glass.

## REPLACING THE WINDSCREEN WIPER BLADES

⚠ 243)

⚠ 89)

Proceed as follows:

- raise the wiper arm, press tab (A) fig. 329 of the attachment spring and remove the blade from the arm;
- fit the new blade, inserting the tab into the special slot in the arm, making sure that it is locked;
- lower the wiper arm onto the windscreen.

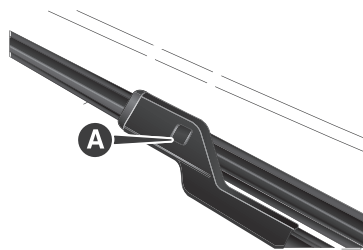

329

F1A0241

## NOZZLES

### Windscreen (washer) fig. 330

If there is no jet, first check that there is fluid in the reservoir.

Then check that the nozzle holes are not clogged; use a needle to unblock them if necessary.

The washer jets should be positioned by adjusting the angle of the sprays using a small straight-headed screwdriver.

The jets should be directed at about a third of the height from the top edge of the windscreen.

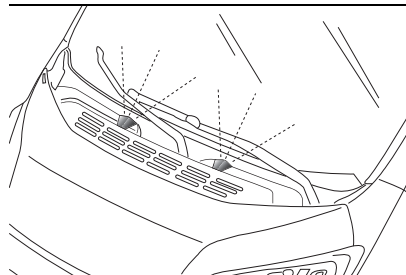

330

F1A0242

## HEADLIGHT WASHERS

Check the correct condition and cleanliness of nozzles at regular intervals.

The headlight washers come on automatically when the windscreen washer is operated with the low beams on.



## IMPORTANT

**243)** *Driving with worn windscreen wiper blades is a serious hazard, because visibility is reduced in bad weather conditions.*



## WARNING

**89)** *Do not operate the windscreen wiper with the blades lifted from the windscreen.*

## LIFTING THE VEHICLE

If the vehicle needs to be lifted, go to a Fiat Dealership which is equipped with the arm hoist or workshop lift. Lift the vehicle exclusively by positioning the jack arms or the shop jack in the points shown in fig. 331.

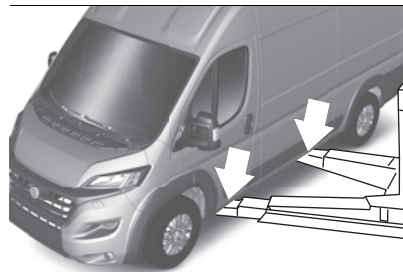

331

F1A0366



## WHEELS AND TYRES

Check the pressure of each tyre including the spare wheel, approximately every two weeks and before long journeys: the pressure should be checked with the tyre rested and cold.

It is normal for the pressure to increase when the vehicle is used; for the correct tyre inflation pressure, see the "Wheels" chapter in the "Technical Specifications" section.

Incorrect pressure causes abnormal tyre wear fig. 332:

- ❑ **A** normal pressure: tread evenly worn;
- ❑ **B** low pressure: tread particularly worn at the edges;
- ❑ **C** high pressure: tread particularly worn in the centre.

The tyres must be replaced when the tread is less than 1.6 mm thick. In any case, follow the laws in force in the country where you are driving.

 244) 245) 246) 247) 248)

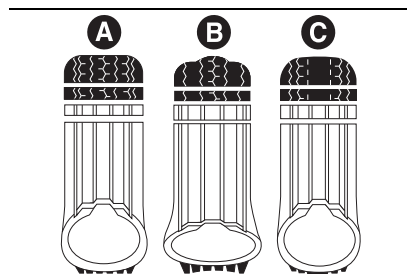

332

F1A0240

### WARNINGS

❑ As far as possible, avoid sharp braking, screech starts and violent shocks against pavements, potholes or other hard obstacles.

Driving for long stretches over uneven roads can damage the tyres;

❑ periodically check that the tyres have no cuts in the side wall, abnormal swelling or irregular tyre tread wear. Go to a Fiat Dealership if required;

❑ avoid overloading the vehicle when travelling: this may cause serious damage to the wheels and tyres;

❑ if a tyre is punctured, stop immediately and charge it to avoid damage to the tyre, the rim, suspensions and steering system;

❑ tyres age even if they are not used much. Cracks in the tread and on the sidewalls are a sign of ageing. In any event, have the tyres checked by

specialised technicians if they have been fitted for longer than 6 years. Remember to check the spare wheel very carefully;

❑ in the case of replacement, always fit new tyres, avoiding those of unknown origin;

❑ if a tyre is changed, also change the inflation valve;

❑ to allow even wear between the front and rear tyres, it is advisable to change them over every 10–15 thousand kilometres, keeping them on the same side of the vehicle so as not to reverse the direction of rotation.

**WARNING** Replacing a tyre, check that the tyre pressure monitoring (TPMS) sensor is also taken from the previous rim, together with the valve.



### IMPORTANT

**244)** Remember that the road holding qualities of your vehicle also depend on the correct inflation pressure of the tyres.

**245)** If tyre pressure is too low, the tyre may overheat and be severely damaged as a result.

**246)** Do not switch tyres from the right-hand side of the vehicle to the left-hand side, and vice versa.

**247)** Do not cross switch the tyres if they are "unidirectional" type. In this case, always take care not to fit the tyres with a



*direction of rotation that is opposite to that indicated: you would risk losing grip and control of the vehicle.*

**248)** *Do not repaint alloy wheel rims at temperatures higher than 150°C. The mechanical features of the wheels could be compromised.*

## SNOW TYRES

A Fiat Dealership will be happy to provide advice concerning the most suitable type of tyre for the customer's requirements.

The performance of these tyres is considerably reduced when the tread depth is less than 4 mm. Replace them in this case.

Due to the specific characteristics of snow tyres, in normal weather conditions or on long motorway journeys, the performance of these tyres is lower than that of standard tyres. Their usage should therefore be restricted in accordance with their type approval.

**WARNING** When using snow tyres with a maximum speed index below the one that can be reached by the vehicle (increased by 5%), place a notice in the passenger compartment, plainly in view, which states the maximum speed allowed by the snow tyres (as per EC Directive).

All four tyres should be the same (brand and track) to ensure greater safety when driving and braking as well as a good manoeuvrability.

Remember that you should not change the rotation direction of the tyres.

 **249)**



### IMPORTANT

**249)** *The maximum speed for snow tyres marked "Q" is 160 km/h, while it is 190 km/h for "T" tyres and 210 km/h for "H" tyres. You should, however, always stick to the speed limits of the highway code.*

## SNOW CHAINS

The use of snow chains should be in compliance with local regulations of each country.

Snow chains can be fitted to the tyres of the front wheels (drive wheels) only. Use of Lineaccessori MOPAR snow chains is recommended. Check the tension of the snow chains after the first few metres have been driven.

 **90)**

**WARNING** With snow chains, use the accelerator with extreme care to prevent, or to limit as much as possible, slipping of the drive wheels

that could cause chain breakage, resulting in damage to the vehicle body or mechanical components.

**WARNING** For versions fitted with 225/75 R16 tyre, use snow chains with max. thickness 16 mm. When travelling on snowy roads with snow chains, it may be helpful to turn the ASR off: in fact, in these conditions, the driving wheels skidding when moving off gives you better traction.



### WARNING

**90)** *Keep the vehicle speed down when snow chains are fitted; never exceed 50 km/h. Avoid potholes, do not drive over steps or pavements, and do not drive long distances over roads without snow, to avoid damaging both your vehicle and the road surface.*



## BODYWORK

### PROTECTION AGAINST ATMOSPHERIC AGENTS

The main causes of corrosion are the following:

- atmospheric pollution;
- salty air and humidity (coastal areas, or hot humid climates);
- seasonal environmental conditions.

The abrasive action of wind-borne atmospheric dust and sand, as well as mud and gravel raised by other cars is also not to be underestimated.

On your vehicle, Fiat has implemented the best manufacturing technologies to effectively protect the bodywork against corrosion.

These include:

- painting products and systems which give the vehicle particular resistance to corrosion and abrasion;
- use of galvanised (or pre-treated) steel sheets, with high resistance to corrosion;
- spraying the underbody, engine compartment, wheelhouse internal parts and other parts with highly protective wax products;
- spraying of plastic parts, with a protective function in the more exposed points: underdoor, inner wing, edges, etc.;

□ use of “open” boxed sections to prevent condensation and pockets of moisture from triggering rust inside.

### VEHICLE BODY AND UNDERBODY WARRANTY

Your vehicle is covered by warranty against perforation due to corrosion of any original element of the structure or body.

For the general terms of this warranty, refer to the Warranty Booklet.

### ADVICE FOR PRESERVING THE BODYWORK

#### Paintwork



Paintwork does not only serve an aesthetic purpose, but also protects the underlying sheet metal.

You are advised to touch up abrasions and scratches immediately to prevent rust formation. Use only original paint products for touch-ups (see “Bodywork paint identification plate” in the “Technical Specifications” section). Normal maintenance of paintwork consists in washing the vehicle: the frequency depends on the conditions and environment where the vehicle is used.

For example, it is advisable to wash the vehicle more often in areas with high

levels of environmental pollution or on roads spread with salt.

To correctly wash the vehicle, proceed as follows:

- wash the bodywork using a low pressure jet of water;
- wipe a sponge with a slightly soapy solution over the bodywork, frequently rinsing the sponge;
- rinse well with water and dry with a jet of air or a chamois leather.

If you put the vehicle through a vehicle wash, follow these recommendations:

- remove the aerial from the roof so it does not get damaged;
- the vehicle should be washed with water added to a soapy solution;
- rinse thoroughly to avoid soap marks remaining on the bodywork or less visible parts.

Dry the less visible parts, such as the door frames, bonnet and the headlight frames with special care, as in these areas water may stagnate more easily. It is a good idea to leave the vehicle outdoors for a while after washing it to give the water time to evaporate. Do not wash the vehicle after it has been left in the sun or with the bonnet hot: this may alter the shine of the paintwork.

Exterior plastic parts should be cleaned in the same way as the rest of the vehicle. Where possible, do not park

the vehicle under trees; the resinous substances released by many species give the paint a dull appearance and increase the possibility of corrosion.

**WARNING** Bird droppings must be washed off immediately and thoroughly as the acid they contain is particularly aggressive.

### Windows

To clean glasses, use specific cleaning products. Use clean cloths to avoid scratching the glass or altering the transparency.

**WARNING** Wipe the rear window inside gently with a cloth following the direction of the filaments to avoid damaging the heating device.

### Headlights

**WARNING** Never use aromatic substances (e.g. petrol) or ketones (e.g. acetone) for cleaning the plastic lenses of the headlights.



## ENGINE COMPARTMENT WASHING



If the engine compartment is washed (at low pressure, e.g. in very dusty areas), this must be done with the engine cold and with ignition device turned to STOP. Take care not to direct the water jet straight at the electronic control modules or the wiper motors. Have this operation performed by a specialised workshop. After washing, check that the various protective components (e.g. rubber guards and caps) have not been removed or damaged.



### WARNING

**91)** Abrasive products and/or polishes should not be used for cleaning the vehicle. Bird droppings must be washed off immediately and thoroughly as the acid they contain is particularly aggressive. Avoid (if at all possible) parking the vehicle under trees; remove vegetable resins immediately as, when dried, it may only be possible to remove them with abrasive products and/or polishes, which is highly inadvisable as they could alter the typical characteristics of the paint. Do not use pure windscreen washer fluid for cleaning the front windscreen and rear window; dilute it min. 50% with water. Only use pure screen washer fluid when strictly necessary due to external temperature

conditions. Do not use chemicals/acids to defrost windows/vehicle glass as they can damage the paint.

**92)** Some automatic systems equipped with old generation blades and/or with a poor maintenance can damage the paint, promoting the creation of microscoring which give an opaque/coated appearance to the paint, especially on dark colours. In this case, just lightly polish with specific products.

**93)** A high pressure jet cleaner should not be used for cleaning the engine compartment. The appropriate precautions have been taken to protect all parts and connections, but the pressures generated by these devices are so high that complete protection against water seepages cannot be guaranteed.



### WARNING

**6)** Detergents pollute the water. Only wash your vehicle in areas equipped to collect and treat waste water from this type of activity.



## INTERIOR

Regularly check that water is not trapped under the mats (due to water dripping off shoes, umbrellas, etc.), as this could cause oxidation of the sheet metal.



250) 251)

### SEATS AND FABRIC PARTS

Use a specific product to clean carpets and fabric upholstery.

Remove dust with a soft brush or a vacuum cleaner.

It is advisable to use a moist brush on velvet upholstery. Rub the seats using a soft microfibre cloth moistened with a solution of water and neutral detergent.

### PLASTIC PARTS

It is advisable to clean interior plastic parts with a moist cloth and a solution of water and non-abrasive mild soap. Use specific products for cleaning plastic, without solvents and specifically designed to prevent damage to the appearance and colour of the treated parts, to remove grease and tough stains.

**WARNING** Do not use alcohol, petrols or derivatives to clean the instrument panel glass.

### LEATHER STEERING WHEEL/GEAR LEVER KNOB/PARKING BRAKE

(for versions/markets, where provided)  
These components must be cleaned with mild soap and water only. Never use alcohol or alcohol-based products. Read the product label carefully before using specific products for cleaning the interiors: make sure that the product does not contain spirits or alcohol-based substances.

If, when cleaning the windscreen with special products, window cleaner accidentally drips onto the leather of the steering wheel/gear lever knob/parking brake, wipe away immediately and then wash the affected area with mild soap and water.

**WARNING** Be careful when using a steering wheel lock device, where applicable, to avoid damaging the leather upholstery by rubbing.



#### IMPORTANT

**250)** *Never use flammable products, such as petroleum ether or modified petrol, to clean the inside of the vehicle. The electrostatic charges which are generated by rubbing during the cleaning operation may cause a fire.*

**251)** *Do not keep aerosol cans in the vehicle: they might explode. Aerosol cans must not be exposed to temperatures higher than 50°C. Temperatures may greatly exceed this value inside a vehicle exposed to direct sunlight.*

## RUBBER HOSES

As far as the maintenance of the braking system and supply system rubber hoses is concerned, follow the "Service Schedule" in this section carefully.

Ozone, high temperatures and prolonged lack of fluid in the system may cause hardening and cracking of the hoses, with possible leaks. Careful checking is therefore necessary.

# TECHNICAL SPECIFICATIONS

*Everything you may find useful for understanding how your vehicle is made and works is contained in this section and illustrated with data, tables and graphics. For the enthusiasts and the technician, but also just for those who want to know every detail of their vehicle.*

|  |     |
|--|-----|
| IDENTIFICATION DATA .....  | 272 |
| ENGINE CODES - BODYWORK<br>VERSION .....                                 | 274 |
| ENGINE .....   | 277 |
| POWER SUPPLY .....   | 278 |
| TRANSMISSION .....   | 279 |
| SUSPENSION.....  | 280 |
| BRAKES .....   | 281 |
| STEERING .....   | 282 |
| WHEELS.....  | 283 |
| DIMENSIONS .....   | 290 |
| PERFORMANCE .....  | 300 |
| WEIGHTS AND LOADS.....   | 303 |
| REFILLING .....  | 306 |
| FLUIDS AND LUBRICANTS .....  | 308 |
| FUEL CONSUMPTION AND<br>CO <sub>2</sub> EMISSIONS .....                  | 311 |
| PRESCRIPTIONS FOR<br>HANDLING THE VEHICLE AT<br>THE END OF ITS LIFE..... | 312 |



## IDENTIFICATION DATA

It is advisable to take note of the identification codes. Identification codes are printed and shown on the plates as indicated below, together with the positions:

- Vehicle identification number (VIN) plate.
- Chassis marking.
- Bodywork paint identification plate.
- Motor marking.

## VEHICLE IDENTIFICATION NUMBER (VIN) PLATE

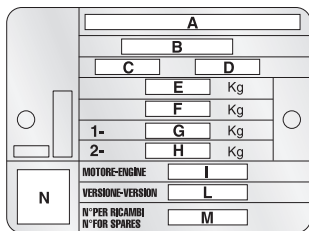

333

F1A0243

This plate is fitted to the engine compartment front crossmember and contains the following data fig. 333:

**A** Name of manufacturer.

- B** Type-approval number.
- C** Vehicle type identification code.
- D** Chassis serial number.
- E** Maximum permitted weight of vehicle fully laden.
- F** Maximum permitted weight of vehicle fully laden plus trailer.
- G** Maximum permitted weight on first axle (front).
- H** Maximum permitted weight on second axle (rear).
- I** Engine type.
- L** Bodywork version code.
- M** Spare part number.
- N** Correct value of smoke coefficient (for diesel engines)

## CHASSIS MARKING

They are located respectively: one on the passenger side interior wheel housing (A) fig. 334 , the other on the lower part of the windscreen fig. 335.

The marking includes:

- type of vehicle;
- chassis serial number.

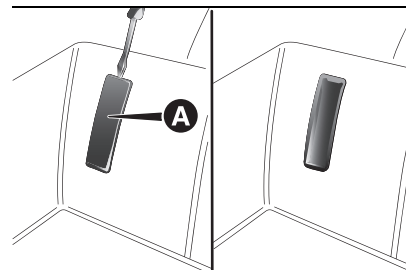

334

F1A0244

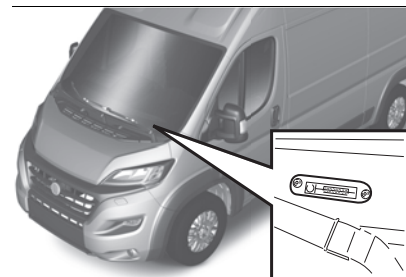

335

F1A0365

## BODYWORK PAINT IDENTIFICATION PLATE

This plate is fitted to the engine compartment front crossmember and contains the following identification data fig. 336:

- A** Paint manufacturer.
- B** Colour name.
- C** Fiat colour code.
- D** Respray and touch up code.

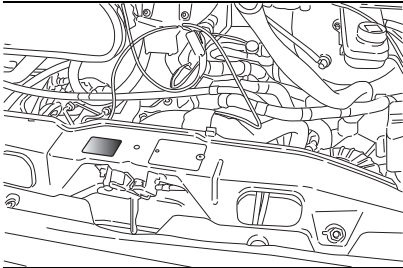

336

F1A0369

## MOTOR MARKING

It is stamped on the cylinder block and includes the type and the engine serial number.



**ENGINE CODES - BODYWORK VERSION**

| Version                          | Engine code |
|----------------------------------|-------------|
| 2.2 120 HP H3-Power with AdBlue® | 46349131    |
| 2.2 140 HP H3-Power with AdBlue® | 46349131    |
| 2.2 160 HP H3-Power with AdBlue® | 46348913    |
| 2.2 180 HP H3-Power with AdBlue® | 46348913    |



## BODYWORK VERSIONS

There is an example of a bodywork version code below by way of explanation with a key which is valid for all bodywork version codes.

Example:

**250 A M M F A DX**

**250** MODEL

**A** GVW

**M** ENGINE

**M** ENGINE AXLES/TRANSMISSION

**F** BODYWORK

**A** WHEELBASE

**DX** VERSION

## GVW

### LIGHT

**S** 2800 kg SHORT

**0** 3000 kg/3040 kg SHORT

**1** 3000 kg/3040 kg MEDIUM

**2** 3000 kg/3040 kg LONG

**3** 3000 kg/3040 kg STRETCHED

**M** 3000 kg/3040 kg MEDIUM/ LONG

**N** 3000 kg/3040 kg TRACTOR

**4** 3300 kg/3340 kg SHORT

**5** 3300 kg/3340 kg MEDIUM

**6** 3300 kg/3340 kg LONG

**7** 3300 kg/3340 kg STRETCHED

**8** 3300 kg/3340 kg TRACTOR

**K** 3300 kg/3340 kg MEDIUM/ LONG

**9** 3500 kg / 3650 kg SHORT

**A** 3500 kg / 3650 kg MEDIUM

**B** 3500 kg / 3650 kg LONG

**C** 3500 kg / 3650 kg STRETCHED

**D** 3500 kg / 3650 kg ROLLING CHASSIS

**L** 3500 kg / 3650 kg MEDIUM / LONG

**T** 3500 kg / 3650 kg XXL EXTRA LONG

### HEAVY

**9** 3500 kg SHORT

**A** 3500 kg MEDIUM

**B** 3500 kg LONG

**C** 3500 kg STRETCHED

**D** 3500 kg ROLLING CHASSIS

**L** 3500 kg MEDIUM / LONG

**T** 3500 kg XXL EXTRA LONG

**E** 4000 kg/4250 kg/4400 kg SHORT

**F** 4000 kg/4250 kg/4400 kg MEDIUM

**G** 4000 kg/4250 kg/4400 kg LONG

**H** 4000 kg/4250 kg/4400 kg STRETCHED

**J** 4000 kg/4250 kg/4400 kg ROLLING CHASSIS

**P** 4000 kg/4250 kg/4400 kg MEDIUM / LONG

**Q** 4000 kg/4250 kg/4400 kg LONG H3

**U** 4000 kg/4250 kg/4400 kg XXL EXTRA LONG

## ENGINE

**K F1A** 2.2 103 kW 140 HP VGT EURO 4 C637

**L F1A** 2.2 103 kW 140 HP VGT EURO 5 C637

**M / 2** 2.2 88 kW 120 HP VGT SCR EURO 6 D FINAL C637

**N / 3** 2.2 103 kW 140 HP VGT SCR EURO 6 D FINAL C637

**P** 2.2 103 kW 140 HP VGT SCR EURO 6 D FINAL 948TE

**Q** 2.2 117 kW 160 HP VGT SCR EURO 6 D FINAL C546

**R** 2.2 117 kW 160 HP VGT SCR EURO 6 D FINAL 948TE

**S / 5** 2.2 130 kW 180 HP VGT SCR EURO 6 D FINAL C546

**T / 6** 2.2 130 kW 180 HP VGT SCR EURO 6 D FINAL 948TE

**U** 2.2 103 kW 140 HP VGT SCR EURO VI E C637

**V** 2.2 103 kW 140 HP VGT SCR EURO VI E 948TE

**W** 2.2 117 kW 160 HP VGT SCR EURO VI E C546

**X** 2.2 117 kW 160 HP VGT SCR EURO VI E 948TE

**Y** 2.2 130 kW 180 HP VGT SCR EURO VI E C546

**Z** 2.2 130 kW 180 HP VGT SCR EURO VI E 948TE



**TRANSMISSION**

**N** Mechanical gearbox

**B** Automatic transmission AT9

**WHEELBASE**

**SHORT(S)** = 0, 4, 9, E

**MEDIUM (M)** = 1, 5, A, F

**MEDIUM-LONG (ML)** = M, K, L, P

**LONG (L)** = 2, 6, B, G

**STRETCHED (XL)** = 3, 7, C, H

**ROLLING CHASSIS** = N, 8, D, J

**EXTRA LONG (XXL)** = T, U

**BODYWORK**

**1** CHASSIS CAB (TEMPO LIBERO)  
LOW ROOF

**2** CHASSIS COWLS (TEMPO LIBERO)

**3** PANELLED VAN (TEMPO LIBERO)  
MEDIUM ROOF

**4** PANELLED VAN (TEMPO LIBERO)  
HIGH ROOF

**5** CHASSIS CAB SPECIAL (TEMPO  
LIBERO) LOW ROOF

**6** SPECIAL CHASSIS COWLS (TEMPO  
LIBERO)

**7** BOX TRUCK SINGLE CAB LOW  
ROOF stretched

**8** PANELLED VAN (TEMPO LIBERO)  
LOW ROOF

**9** BOX TRUCK CREW CAB LOW  
ROOF

**A** PANELLED VAN HIGH ROOF

**B** GLAZED VAN HIGH ROOF

**C** CHASSIS SINGLE CAB LOW ROOF

**D** CHASSIS CREW CAB LOW ROOF

**E** GLAZED VAN (TEMPO LIBERO)  
LOW ROOF

**F** GLAZED VAN (TEMPO LIBERO)  
MEDIUM ROOF

**G** PANELLED VAN MEDIUM ROOF

**H** GLAZED VAN MEDIUM ROOF

**I** COMBI MODULAR CONVERTED  
MEDIUM ROOF

**J** COMBI MEDIUM ROOF

**K** COMBI LOW ROOF

**L** PANELLED VAN LOW ROOF

**M** MINIBUS MEDIUM ROOF

**N** COMBI MODULAR CONVERTED  
MEDIUM ROOF

**P** PANORAMA LOW ROOF

**Q** PANORAMA MEDIUM ROOF

**R** MINIBUS BASE (295) MEDIUM  
ROOF

**T** COMBI MEDIUM ROOF

## ENGINE

| General information                   | 2.2 120 HP H3-Power with AdBlue®                | 2.2 140 HP H3-Power with AdBlue® | 2.2 160 HP H3-Power with AdBlue® | 2.2 180 HP H3-Power with AdBlue® |
|---------------------------------------|---|----------------------------------|----------------------------------|----------------------------------|
| Engine code                           | 46349131  | 46349131                         | 46348913                         | 46348913                         |
| Cycle                                 | Diesel  | Diesel                           | Diesel                           | Diesel                           |
| Number and position of cylinders      | 4 in line                                       | 4 in line                        | 4 in line                        | 4 in line                        |
| Piston bore and stroke (mm)           | 83.8 x 99                                       | 83.8 x 99                        | 83.8 x 99                        | 83.8 x 99                        |
| Total displacement (cm <sup>3</sup> ) | 2184  | 2184                             | 2184                             | 2184                             |
| Compression ratio                     | 15.7 : 1  | 15.7 : 1                         | 15.7 : 1                         | 15.7 : 1                         |
| Maximum power (CEE) (kW)              | 88  | 103                              | 118                              | 132                              |
| Maximum power (CEE) (HP)              | 120   | 140                              | 160                              | 180                              |
| Corresponding engine speed (rpm)      | 3500  | 3500                             | 3500                             | 3500                             |
| Maximum torque (CEE) (Nm)             | 320   | 350 (MT)<br>380 (AT)             | 380 (MT)<br>400 (AT)             | 380 (MT)<br>450 (AT)             |
| Corresponding engine speed (rpm)      | 1400  | 1400 (MT and AT)                 | 1500 (MT and AT)                 | 1500 (MT and AT)                 |
| Fuel                                  | Diesel for motor vehicles (EN590 Specification) |                                  |                                  |                                  |



## POWER SUPPLY

---

### Versions

Diesel



### Intake system

Common Rail direct injection

---



### IMPORTANT

**252)** *Modifications or repairs to the fuel supply system that are not carried out properly or do not take the system's technical specifications into account can cause malfunctions leading to the risk of fire.*

# TRANSMISSION

| Versions                   | Transmission                     | Clutch   | Traction                                 |       |
|----------------------------|----------------------------------|--|--|-------|
| MANUAL TRANSMISSION        | 2.2 120 HP H3-Power with AdBlue® |  |  |       |
|                            | 2.2 140 HP H3-Power with AdBlue® | Six forward gears plus reverse with synchronisers for forward gear engagement    | Self-adjusting pedal without idle stroke |       |
|                            | 2.2 160 HP H3-Power with AdBlue® |  |  |       |
|                            | 2.2 180 HP H3-Power with AdBlue® |  |  | Front |
| AT9 AUTOMATIC TRANSMISSION | 2.2 140 HP H3-Power with AdBlue® |  |  |       |
|                            | 2.2 160 HP H3-Power with AdBlue® | Nine forward gears plus reverse with synchronisers for forward gears and reverse | -  |       |
|                            | 2.2 180 HP H3-Power with AdBlue® |  |  |       |



## SUSPENSION

---



| Front                        | Rear  |
|------------------------------|---|
| McPherson independent wheels | Tubular rigid beam axle; longitudinal leaf spring |

---



### WARNING

**94)** *Carefully check that the composite leaf springs do not come in contact with any kind of acid*

# BRAKES

|  | Front service brakes  | Rear service brakes   | Parking brake  |
|--|-----------------------|-----------------------|--|
| Versions with mechanical parking brake     | Self-ventilated discs | Disc                  | Controlled by handbrake lever, acting on the rear brakes |
| Versions with electric parking brake (EPB) | Self-ventilated discs | Self-ventilated discs | Electric   |

**WARNING** Water, ice and salt spread on the roads may deposit on the brake discs reducing braking efficiency the first time the brakes are applied.



## STEERING

| Versions              | Kerb-to-kerb turning circle (m) | Type  |
|-----------------------|---------------------------------|---|
| Short wheelbase       | 11.06                           | Rack and pinion with electric power steering. |
| Medium wheelbase      | 12.46                           |   |
| Medium-long wheelbase | 13.54                           |   |
| Long wheelbase        | 14.28                           |   |
| Extra-long wheelbase  | 15.3                            |   |



## WHEELS

### RIMS AND TYRES

Alloy or pressed steel rims. Tubeless radial carcass tyres.

All approved tyres are listed in the registration document.

**WARNING** If there are any discrepancies between the Owner Handbook and the Registration Document, take the information from the latter. To ensure driving safety, make sure that all the wheels are fitted with tyres of the same make and type.

**WARNING** Do not use air chambers with tubeless tyres.

### SPARE WHEEL

Pressed steel rim.  
Tubeless tyre.

### WHEEL GEOMETRY

Front wheels toe-in measured between rims:  $-1 \pm 1$  mm.

The values refer to the vehicle in running order.

### CORRECT READING OF THE TYRE

**Example:** 215/70 R 15 109S (see fig. 337)

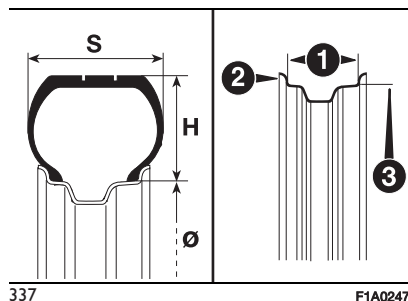

**215** Nominal width (S, distance in mm between sides)

**70** Height/width ratio (H/S), expressed as a percentage

**R** Radial tyre

**15** Rim diameter in inches ( $\varnothing$ )

**109** Load rating (capacity)

**S** Maximum speed rating

### Maximum speed index

**Q** up to 160 km/h

**R** up to 170 km/h

**S** up to 180 km/h

**T** up to 190 km/h

**U** up to 200 km/h

**H** up to 210 km/h

**V** up to 240 km/h

### Maximum speed index for snow tyres

**QM + S** up to 160 km/h

**TM + S** up to 190 km/h

**HM + S** up to 210 km/h

### Load index (capacity)

|             |               |
|-------------|---------------|
| 70 = 335 kg | 95 = 690 kg   |
| 71 = 345 kg | 96 = 710 kg   |
| 72 = 355 kg | 97 = 730 kg   |
| 73 = 365 kg | 98 = 750 kg   |
| 74 = 375 kg | 99 = 775 kg   |
| 75 = 387 kg | 100 = 800 kg  |
| 76 = 400 kg | 101 = 825 kg  |
| 77 = 412 kg | 102 = 850 kg  |
| 78 = 425 kg | 103 = 875 kg  |
| 79 = 437 kg | 104 = 900 kg  |
| 80 = 450 kg | 105 = 925 kg  |
| 81 = 462 kg | 106 = 950 kg  |
| 82 = 475 kg | 107 = 975 kg  |
| 83 = 487 kg | 108 = 1000 kg |
| 84 = 500 kg | 109 = 1030 kg |
| 85 = 515 kg | 110 = 1060 kg |
| 86 = 530 kg | 111 = 1090 kg |
| 87 = 545 kg | 112 = 1120 kg |
| 88 = 560 kg | 113 = 1150 kg |
| 89 = 580 kg | 114 = 1180 kg |



|             |               |
|-------------|---------------|
| 90 = 600 kg | 115 = 1215 kg |
| 91 = 615 kg | 116 = 1250 kg |
| 92 = 630 kg | 117 = 1285 kg |
| 93 = 650 kg | 118 = 1320 kg |
| 94 = 670 kg | 119 = 1360 kg |

### RIM PROTECTOR TYRES

 253)

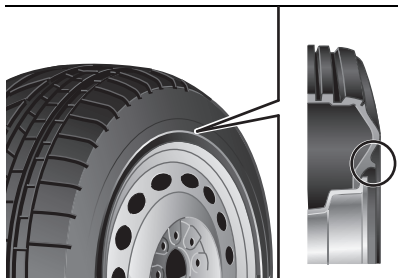

338

F1A0248



#### IMPORTANT

**253)** Do not fit wheel cups when using integral cups fixed (with springs) to the steel rim and tyres other than factory-fitted tyres provided with Rim Protector fig. 338. Use of unsuitable tyres and wheel caps may cause sudden decrease of tyre pressure.

## RIMS AND TYRES PROVIDED

Rims for versions with manual transmission

| VERSION                   | PAYLOAD     | TYRES                              |                                 |                                    | RIM       |
|---------------------------|-------------|------------------------------------|---------------------------------|------------------------------------|-----------|
|                           |             | <i>(Size/Load index and speed)</i> |                                 |                                    |           |
| LIGHT 15"                 | 3000        | 215/70 R15 C<br>(109/107 S)        | 225/70 R15C<br>(112/110 S)      | 225/70 R15C<br>(112/110 R) M+S     | 6 Jx15-68 |
|                           | 3300        |                                    |                                 |                                    |           |
|                           | 3500        |                                    |                                 |                                    |           |
| LIGHT TEMPO<br>LIBERO 15" | 3000        | 215/70 R15 CP<br>(109/107 Q)       | -                               | 225/70 R15C<br>(112/110 R) M+S     |           |
|                           | 3300        |                                    | -                               | 215/70 R15 CP<br>(109/107 R) M+S   |           |
|                           | 3500 / 3650 |                                    | -                               |                                    |           |
| LIGHT 16"                 | 3300        | 215/75 R16 C<br>(116/114 R)        | 225/75 R16C<br>(116/114 R)      | 225/75 R16C<br>(116/114 R) M+S     | 6 Jx16-68 |
|                           | 3500        |                                    | 225/75 R16C<br>(118/116 R)      | 225/75 R16C<br>(121/120 S) M+S     |           |
| LIGHT TEMPO<br>LIBERO 16" | 3300        | 225/75 R16 CP<br>(116/114 Q)       | 225/75 R16CP<br>(118/116 R) M+S | 225/75 R16C<br>(121/120 S) M+S (*) |           |
|                           | 3500 / 3650 |                                    |                                 |                                    |           |



| VERSION              | PAYLOAD     | TYRES   |                                 |  | RIM       |
|----------------------|-------------|---|---------------------------------|--|-----------|
|                      |             | <i>(Size/Load index and speed)</i>                  |                                 |  |           |
| MAXI                 | 3500        | 215/75 R16C<br>(116/114 R)                          | 225/75 R16C<br>(116/114 R)      | 225/75 R16C<br>(116/114 R) M+S<br>225/75 R16C<br>(121/120 S) M+S<br>225/75 R16C<br>(121/120 S) M+S (*) | 6 Jx16-68 |
|                      | 4000 / 4250 | 215/75 R16C<br>(116/114 R)<br>excluding GWV<br>4250 | 225/75 R16C<br>(118/116 R)      |  |           |
| MAXI TEMPO<br>LIBERO | 3500        | 225/75 R16 CP<br>(116/114 Q)                        | 225/75 R16CP<br>(118/116 R) M+S |  |           |
|                      | 4000 / 4250 |   |                                 |  |           |
|                      | 4400        |   |                                 |  |           |

(\*) UNIDIRECTIONAL tyres: do not cross switch the tyres if they are "unidirectional" type. Observe the label carefully when using a unidirectional tyre as a spare.

**Rims for versions with automatic transmission**

| VERSION                   | PAYLOAD | TYRES                              |                            |  | RIM       |
|---------------------------|---------|------------------------------------|----------------------------|--|-----------|
|                           |         | <i>(Size/Load index and speed)</i> |                            |  |           |
| LIGHT 15"                 | 3000    | 215/70 R15 C<br>(109/107 S)        | 225/70 R15C<br>(112/110 S) | 225/70 R15C<br>(112/110 R) M+S                                     | 6 Jx15-68 |
| LIGHT TEMPO<br>LIBERO 15" | 3000    | 215/70 R15 CP<br>(109/107 Q)       | -                          | 225/70 R15C<br>(112/110 R) M+S<br>215/70 R15 CP<br>(109/107 R) M+S |           |

| VERSION                       | PAYLOAD        | TYRES   |                                 |                                    | RIM                            |
|-------------------------------|----------------|---|---------------------------------|------------------------------------|--------------------------------|
|                               |                | <i>(Size/Load index and speed)</i>                    |                                 |                                    |                                |
| <b>LIGHT 16"</b>              | 3300           | 215/75 R16 C<br>(116/114 R)                           | 225/75 R16C<br>(116/114 R)      | 225/75 R16C<br>(116/114 R) M+S     | 6 Jx16-68                      |
|                               | 3500           |   | 225/75 R16C<br>(118/116 R)      | 225/75 R16C<br>(121/120 S) M+S     |                                |
| <b>LIGHT TEMPO LIBERO 16"</b> | 3300/3500/3650 | 225/75 R16 CP<br>(116/114 Q)                          | 225/75 R16CP<br>(118/116 R) M+S | 225/75 R16C<br>(121/120 S) M+S (*) |                                |
| <b>MAXI</b>                   | 3500           | 215/75 R16C<br>(116/114 R)                            | 225/75 R16C<br>(116/114 R)      | 225/75 R16C<br>(116/114 R) M+S     |                                |
|                               | 4000 / 4250    | 215/75 R16C<br>(116/114 R)<br>excluding GVW<br>4250kg | 225/75 R16C<br>(118/116 R)      |                                    | 225/75 R16C<br>(121/120 S) M+S |
| <b>MAXI TEMPO LIBERO</b>      | 3500           | 225/75 R16 CP<br>(116/114 Q)                          | 225/75 R16CP<br>(118/116 R) M+S | 225/75 R16C<br>(121/120 S) M+S (*) |                                |
|                               | 4000 / 4250    |   |                                 |                                    |                                |
|                               | 4400           |   |                                 |                                    |                                |

(\*) UNIDIRECTIONAL tyres: do not cross switch the tyres if they are "unidirectional" type. Observe the label carefully when using a unidirectional tyre as a spare.

If using M+S winter tyres with speed index lower than "S" for 15" wheels and "R" for 16" wheels, respect the max. vehicle speed indicated in the table: Maximum speed index.

**WARNING** Only use the tyres indicated on the vehicle Registration document. If using class C tyres on a Camping vehicle, always use wheels with a metal inflation valve. When replacing, it is always advisable to use Camping tyres.



**COLD TYRE INFLATION PRESSURE (bar)**

|                   | Tyres provided  | Front | Rear |
|-------------------|---|-------|------|
| 215/70 R15 C      | 3000 GVW (*) excluding PANORAMA   | 4.0   | 4.0  |
|                   | 3300 GVW (*)?/ 3500 GVW (*)   | 4.1   | 4.5  |
| 215/70 R15 C      | PANORAMA  | 4.1   | 4.5  |
| 225/70 R15 C (*)  | 3000 GVW (*) excluding PANORAMA   | 4.0   | 4.0  |
|                   | 3300 GVW (*)?/ 3500 GVW (*)   | 4.1   | 4.5  |
| 225/70 R15 C (*)  | Winter and All-Seasons tyres  | 4.1   | 4.5  |
| 225/70 R15 C (*)  | PANORAMA  | 4.1   | 4.5  |
| 215/70 R15 CP     | Vehicles with Camping tyres   | 5.0   | 5.5  |
| 215/75 R16 C      | For all versions/trim levels  | 4.5   | 5.0  |
| 225/75 R16 C (*)  | For all versions/trim levels, except for Winter and Camper tyres            | 4.5   | 5.0  |
| 225/75 R16 C (*)  | Winter tyres  | 4.5   | 4.8  |
| 225/75 R16 C (*)  | All-Seasons tyres   | 4.5   | 5.0  |
| 225/75 R16 C (*)  | Specific tyres for Camper   | 5.5   | 5.5  |
| 225/75 R16 CP (*) | Vehicles with Camping tyres   | 5.5   | 5.5  |
| 225/75 R16 CP (*) | Maxi 4400 GVW (*) with Camping tyres (for versions/markets, where provided) | 5.5   | 5.5  |

(\*) Gross Vehicle Weight

(°) Oversized tyres

The pressure value can be up to +1.0 bar more than the recommended one when the tyres are warm. However, recheck that the value is correct with the tyre cold.



## DIMENSIONS

### PANORAMA / COMBI VERSION

Dimensions are expressed in mm and refer to the vehicle fitted with standard tyres.  
Height is measured with vehicle unladen.

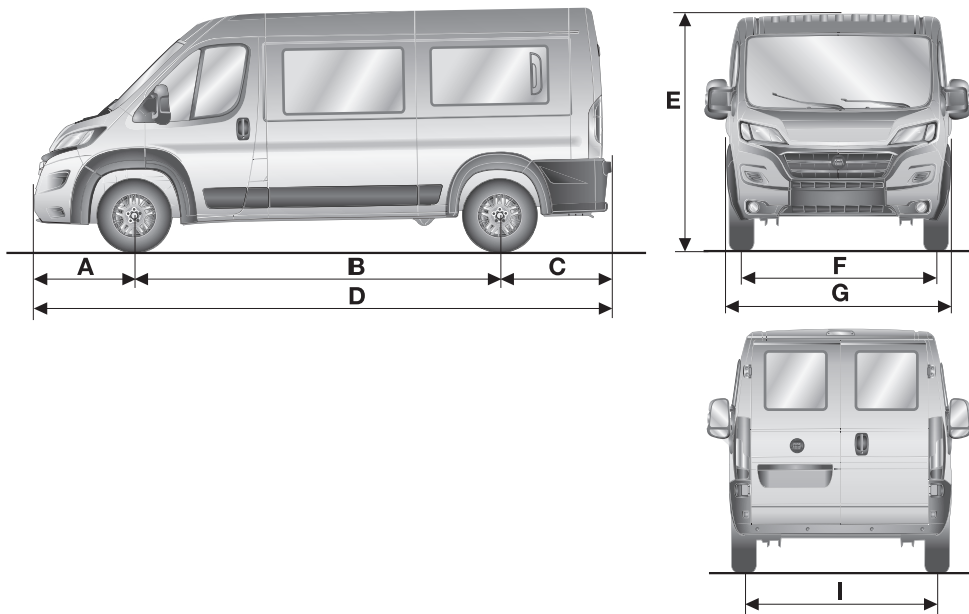

339

F1A0867



COMBI - PANORAMA

|          | CH1  | MH2  | LH2             |
|----------|------|------|-----------------|
| <b>A</b> | 948  | 948  | 948             |
| <b>B</b> | 3000 | 3450 | 4035            |
| <b>C</b> | 1015 | 1015 | 1015 - 1380 (*) |
| <b>D</b> | 4963 | 5413 | 5998 - 6363(*)  |
| <b>E</b> | 2254 | 2524 | 2524            |
| <b>F</b> | 1810 | 1810 | 1810            |
| <b>G</b> | 2050 | 2050 | 2050            |
| <b>I</b> | 1790 | 1790 | 1790            |

(\*) MINIBUS version, 16 + 1 seats

The sizes vary according to the various versions within the limits indicated above.



**VAN VERSION**

Dimensions are expressed in mm and refer to the vehicle fitted with standard tyres.  
 Height is measured with vehicle unladen.

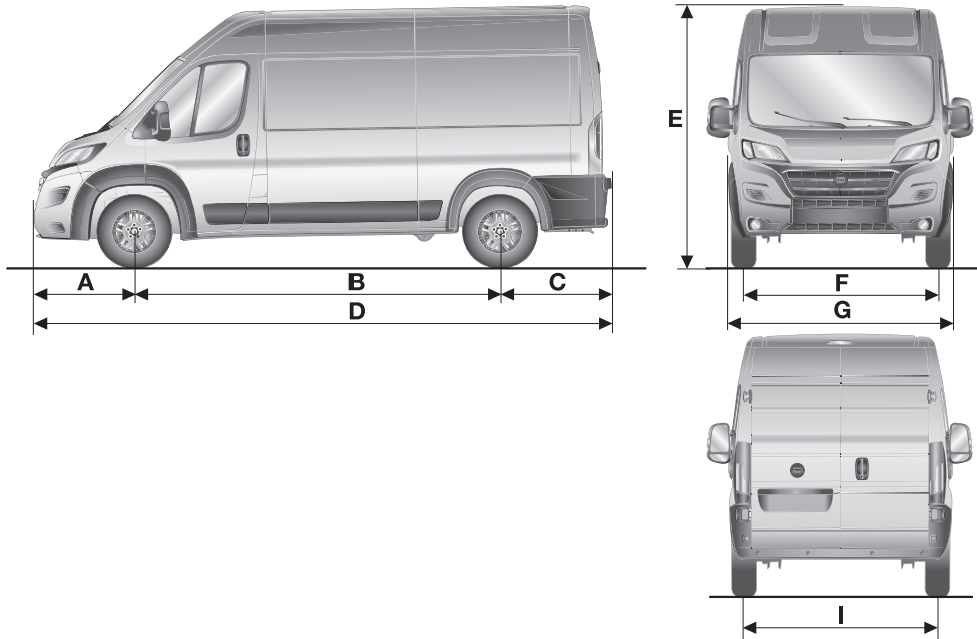

340

F1A0328

|          | VAN         |                 |                  |             |
|----------|-------------|-----------------|------------------|-------------|
|          | CH1 - CH2   | MH1 - MH2       | LH2 - LH3        | XLH2 - XLH3 |
| <b>A</b> | 948         | 948             | 948              | 948         |
| <b>B</b> | 3000        | 3450            | 4035             | 4035        |
| <b>C</b> | 1015        | 1015            | 1015             | 1380        |
| <b>D</b> | 4963        | 5413            | 5998             | 6363        |
| <b>E</b> | 2254 - 2524 | 2254 - 2524 (*) | 2524 - 2764 (**) | 2524 - 2764 |
| <b>F</b> | 1810        | 1810            | 1810             | 1810        |
| <b>G</b> | 2050        | 2050            | 2050             | 2050        |
| <b>I</b> | 1790        | 1790            | 1790             | 1790        |

(\*) MAXI 2269 - 2539 version

(\*\*) MAXI 2539 - 2774 version

The sizes vary according to the various versions within the limits indicated above.



**TRUCK VERSION**

Dimensions are expressed in mm and refer to the vehicle fitted with standard tyres.  
 Height is measured with vehicle unladen.

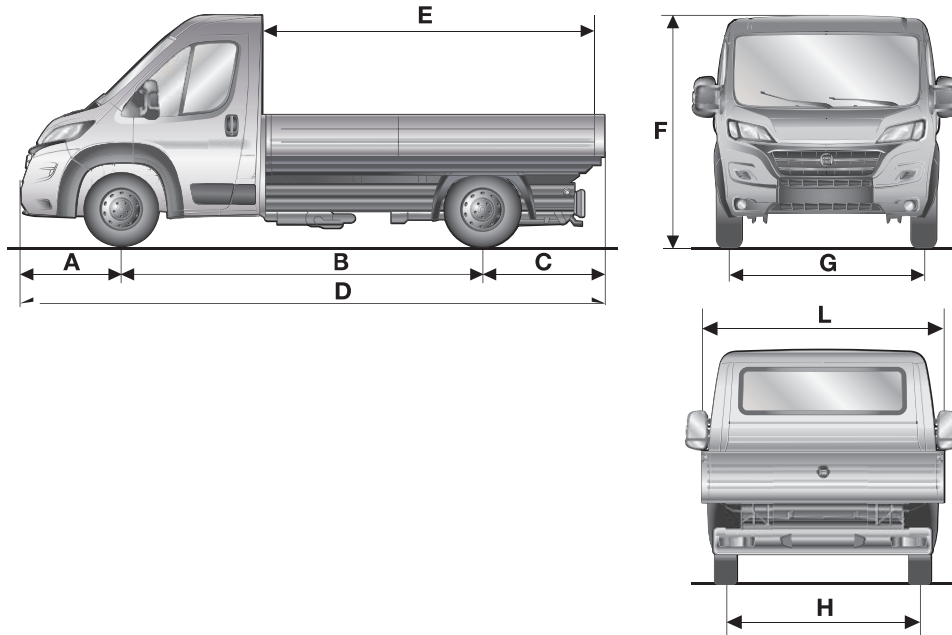

341

F1A0329

|          | TRUCK BODY |      |      |      | CHASSIS CAB    |                |                |                |             |
|----------|------------|------|------|------|----------------|----------------|----------------|----------------|-------------|
|          | CH1        | MH1  | LH1  | XLH1 | CH1            | MH1 -<br>MLH1  | LH1            | XLH1           | XXLH1       |
| <b>A</b> | 948        | 948  | 948  | 948  | 948            | 948            | 948            | 948            | 948         |
| <b>B</b> | 3000       | 3450 | 4035 | 4035 | 3000           | 3450 -<br>3800 | 4035           | 4035           | 4300        |
| <b>C</b> | 1345       | 1345 | 1345 | 1710 | 960            | 960            | 960            | 1325           | 1590        |
| <b>D</b> | 5293       | 5743 | 6328 | 6693 | 4908           | 5358 -<br>5708 | 5943           | 6308           | 6573        |
| <b>E</b> | 2798       | 3248 | 3833 | 4198 | -              | -              | -              | -              | -           |
| <b>F</b> | 2424       | 2424 | 2424 | 2424 | 2254           | 2254           | 2254           | 2254           | 2519        |
| <b>G</b> | 1810       | 1810 | 1810 | 1810 | 1810           | 1810           | 1810           | 1810           | 1810        |
| <b>H</b> | 1790       | 1790 | 1790 | 1790 | 1790 -<br>1980 | 1790 -<br>1980 | 1790 -<br>1980 | 1790 -<br>1980 | 1790 - 1980 |
| <b>L</b> | 2100       | 2100 | 2100 | 2100 | 2050           | 2050           | 2050           | 2050           | 2050        |

The sizes vary according to the various versions within the limits indicated above.



|          | CHASSIS COWL   |                |                |                |                | SPECIAL CAB VAN |                |                |                |                |
|----------|----------------|----------------|----------------|----------------|----------------|-----------------|----------------|----------------|----------------|----------------|
|          | CH1            | MH1 -<br>MLH1  | LH1            | XLH1           | XXLH1          | CH1             | MH1 -<br>MLH1  | LH1            | XLH1           | XXLH1          |
| <b>A</b> | 925            | 925            | 925            | 925            | 925            | 948             | 948            | 948            | 948            | 948            |
| <b>B</b> | 3000           | 3450 -<br>3800 | 4035           | 4035           | 4300           | 3000            | 3450 -<br>3800 | 4035           | 4035           | 4300           |
| <b>C</b> | 860            | 860            | 860            | 1225           | 1490           | 880             | 880            | 880            | 1245           | 1510           |
| <b>D</b> | 4785           | 5235 -<br>5585 | 5820           | 6125           | 6390           | 4828            | 5278 -<br>5628 | 5863           | 6228           | 6493           |
| <b>E</b> | -              | -              | -              | -              | -              | -               | -              | -              | -              | -              |
| <b>F</b> | -              | -              | -              | -              | -              | 2254            | 2254           | 2254           | 2254           | 2254           |
| <b>G</b> | 1810           | 1810           | 1810           | 1810           | 1810           | 1810            | 1810           | 1810           | 1810           | 1810           |
| <b>H</b> | 1790 -<br>1980 | 1790 -<br>1980 | 1790 -<br>1980 | 1790 -<br>1980 | 1790 -<br>1980 | 1790 -<br>1980  | 1790 -<br>1980 | 1790 -<br>1980 | 1790 -<br>1980 | 1790 -<br>1980 |
| <b>L</b> | 2050           | 2050           | 2050           | 2050           | 2050           | 2050            | 2050           | 2050           | 2050           | 2050           |

The sizes vary according to the various versions within the limits indicated above.

## SPECIAL CHASSIS COWL

|          | CH1         | MH1 - MH2   | LH1         | XLH1        | XXLH1       |
|----------|-------------|-------------|-------------|-------------|-------------|
| <b>A</b> | 925         | 925         | 925         | 925         | 925         |
| <b>B</b> | 3000        | 3450 - 3800 | 4035        | 4035        | 4300        |
| <b>C</b> | 880         | 880         | 880         | 1245        | 1510        |
| <b>D</b> | 4805        | 5255 - 5605 | 5840        | 6205        | 6470        |
| <b>G</b> | 1810        | 1810        | 1810        | 1810        | 1810        |
| <b>H</b> | 1790 - 1980 | 1790 - 1980 | 1790 - 1980 | 1790 - 1980 | 1790 - 1980 |
| <b>L</b> | 2050        | 2050        | 2050        | 2050        | 2050        |

The sizes vary according to the various versions within the limits indicated above.



**CREW CAB VERSION**

Dimensions are expressed in mm and refer to the vehicle fitted with standard tyres.  
 Height is measured with vehicle unladen.

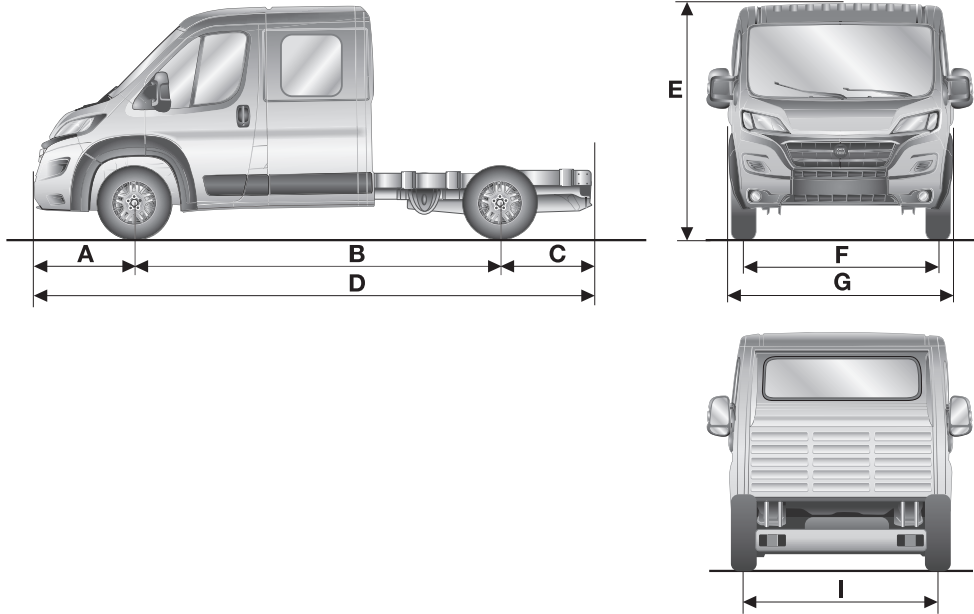

342

F1A0368



|          | CREW CAB |      |      |
|----------|----------|------|------|
|          | MH1      | LH1  | XLH1 |
| <b>A</b> | 948      | 948  | 948  |
| <b>B</b> | 3450     | 4035 | 4035 |
| <b>C</b> | 1340     | 1245 | 1695 |
| <b>D</b> | 5798     | 6228 | 6678 |
| <b>E</b> | 2424     | 2424 | 2424 |
| <b>F</b> | 1810     | 1810 | 1810 |
| <b>G</b> | 2100     | 2100 | 2100 |
| <b>I</b> | 1790     | 1790 | 1790 |

The sizes vary according to the various versions within the limits indicated above.



## PERFORMANCE

Top permitted speed after initial vehicle use in km/h.

### Versions with manual transmission

| BODYWORK VERSION   | 2.2 120 HP<br>H3-Power<br>with<br>AdBlue®                   | 2.2 140 HP H3-Power<br>with AdBlue® |       | 2.2 160 HP H3-Power<br>with AdBlue® |       | 2.2 180 HP H3-Power<br>with AdBlue® |                     |     |
|--|---|-------------------------------------|-------|-------------------------------------|-------|-------------------------------------|---------------------|-----|
|  | Light   | Light                               | Heavy | Light                               | Heavy | Light (*)                           | Heavy (**)          |     |
| VAN (excluding<br>Tempo Libero<br>version)   | LOW roof (H1)   | 148                                 | 156   |                                     | 163   | 162                                 | 170 (*)<br>161 (**) | 161 |
|  | MEDIUM roof (H2)  | 143                                 | 153   |                                     | 159   | 158                                 | 165 (*)<br>161 (**) | 161 |
|  | HIGH roof (H3)  | 138                                 | 149   |                                     | 154   | 153                                 | 161                 | 156 |
| TRAILER<br>TRUCK / CAB<br>CHASSIS /<br>CHASSIS<br>COWLS /<br>PLATFORMS<br>(excluding<br>Tempo Libero<br>version) | LOW roof (H1)   | 148                                 | 156   |                                     | 163   | 162                                 | 170 (*)<br>161 (**) | 161 |
|  | CAB CHASSIS<br>/ CHASSIS<br>COWLS (Tempo<br>Libero version) | LOW roof (H1)                       | 148   | 152                                 |       | 152                                 |                     | 152 |

| BODYWORK VERSION | 2.2 120 HP H3-Power with AdBlue® | 2.2 140 HP H3-Power with AdBlue® |       | 2.2 160 HP H3-Power with AdBlue® |       | 2.2 180 HP H3-Power with AdBlue® |            |
|------------------|----------------------------------|----------------------------------|-------|----------------------------------|-------|----------------------------------|------------|
|                  | Light                            | Light                            | Heavy | Light                            | Heavy | Light (*)                        | Heavy (**) |
| LOW roof (H1)    | 148                              | 152                              |       | 152                              |       | 152                              |            |
| MEDIUM roof (H2) | 146                              | 152                              |       | 152                              |       | 152                              |            |
| HIGH roof (H3)   | 141                              | 149                              |       | 152                              |       | 152                              |            |

**VAN (Tempo Libero version)**

(\*) Versions with 15" rims  
 (\*\*) Versions with 16" rims



**Versions with automatic transmission**

| BODYWORK VERSION  |                  | 2.2 140 HP H3-Power with AdBlue® |       | 2.2 160 HP H3-Power with AdBlue® |       | 2.2 180 HP H3-Power with AdBlue® |       |
|---|------------------|----------------------------------|-------|----------------------------------|-------|----------------------------------|-------|
|   |                  | Light                            | Heavy | Light                            | Heavy | Light                            | Heavy |
| <b>VAN (excluding Tempo Libero version)</b>   | LOW roof (H1)    | 155                              |       | 162 (R15)<br>161 (R16)           |       | 169 (R15)<br>161 (R16)           | 161   |
|   | MEDIUM roof (H2) | 152                              |       | 158                              |       | 164 (R15)<br>161 (R16)           | 161   |
|   | HIGH roof (H3)   | 148                              |       | 153                              |       | 160                              |       |
| <b>TRAILER TRUCK / CAB CHASSIS / CHASSIS COWLS / PLATFORMS (excluding Tempo Libero version)</b> | LOW roof (H1)    | 155                              |       | 162 (R15)<br>161 (R16)           |       | 169 (R15)<br>161 (R16)           | 161   |
|   | LOW roof (H1)    | 152                              |       | 152                              |       | 152                              |       |
| <b>VAN (Tempo Libero version)</b>   | LOW roof (H1)    | 152                              |       | 152                              |       | 152                              |       |
|   | MEDIUM roof (H2) | 152                              |       | 152                              |       | 152                              |       |
|   | HIGH roof (H3)   | 148                              |       | 152                              |       | 152                              |       |

NOTE N2-category vehicles are limited to 90 km/h by type-approval requirements.

NOTE M2-category vehicles are limited to 100 km/h by type-approval requirements.

Speed limiter type-approved for 171 km/h for complete/incomplete No Tempo Libero with 15"

(\*) Speed limiter type-approved for 161 km/h for complete/incomplete No Tempo Libero with 16"

(\*\*) Speed limiter type-approved for 152 km/h for Tempo Libero

## WEIGHTS AND LOADS

To identify the weights and loads for your vehicle, refer to the plate shown in fig. 343 and described in the "Vehicle identification number (VIN) plate" paragraph or refer to the vehicle registration certificate showing the type-approved weights (for markets, where provided).

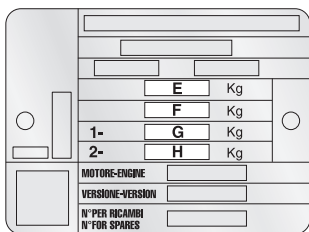

343

F1A0245

- E** Maximum permitted weight of fully laden vehicle (GVW).
- F** Maximum permitted weight of the vehicle (GVW) fully laden plus trailer. If there is no value in the field or if there is a dash, it means that the vehicle cannot tow
- G** Maximum permitted weight on first axle (front).

**H** Maximum permitted weight on second axle (rear).

To calculate the towable weight with a braked trailer, take the difference between values F and E shown on the plate.

E.g.: F=6000 kg - E=3500 kg

Braked trailer=2500 kg

**ATTENTION** *Do not exceed the indicated trailer and towable weights.*  
**IMPORTANT** *Comply with the vehicle towing capacities.*

The tables show the towable weight for engine version.



**TOWABLE WEIGHTS (kg)**

**Key:**

**A** = TOWABLE WEIGHT

**B** = UNBRAKED TRAILER

**C** = LOAD ON TOW HOOK

|       | VERSION (GVW)            | ENGINE                           | A                                | B    | C      |     |
|-------|--------------------------|----------------------------------|----------------------------------|------|--------|-----|
| LIGHT | 2800                     | 2.2 120 HP H3-Power with AdBlue® | 2000                             | 750  | 100    |     |
|       | 3000/3300/3500/3510      |                                  | 2500                             | 750  | 100    |     |
|       | 3000/3300/3500/3510      | 2.2 140 HP H3-Power with AdBlue® | 2500                             | 750  | 100    |     |
|       | 3650 (T.L. Tempo Libero) |                                  | 2500                             | 750  | 100    |     |
|       |                          | 3000/3300/3500/3510/3650         | 2.2 160 HP H3-Power with AdBlue® | 2500 | 750    | 100 |
|       |                          | 3300/3500/3510/3650              | 2.2 180 HP H3-Power with AdBlue® | 2500 | 750    | 100 |
| MAXI  | 3500                     | 2.2 140 HP H3-Power with AdBlue® | 3000(*)                          | 750  | 120(*) |     |
|       | 3510                     |                                  | 3000                             | 750  | 100    |     |
|       | 3995 / 4005              |                                  | 2500                             | 750  | 100    |     |
|       | 4250                     |                                  | 2250                             | 750  | 100    |     |
|       | 3500                     |                                  | 3000(*)                          | 750  | 120(*) |     |
|       | 3510                     | 2.2 160 HP H3-Power with AdBlue® | 3000                             | 750  | 100    |     |
|       | 3995 / 4005              |                                  | 2500                             | 750  | 100    |     |
|       | 4250                     |                                  | 2250                             | 750  | 100    |     |
|       | 4400                     |                                  | 2100                             | 750  | 100    |     |

| VERSION (GVW) |             | ENGINE                           | A       | B   | C      |
|---------------|-------------|----------------------------------|---------|-----|--------|
| MAXI          | 3500        | 2.2 180 HP H3-Power with AdBlue® | 3000(*) | 750 | 120(*) |
|               | 3510        |                                  | 3000    | 750 | 100    |
|               | 3995 / 4005 |                                  | 2500    | 750 | 100    |
|               | 4250        |                                  | 2250    | 750 | 100    |
|               | 4400        |                                  | 2100    | 750 | 100    |

(\*) For Special T.L. 3500 Kg (towable weight = 100 Kg)

**NOTE The following vehicles are excluded from the table:**

**Key:**

**A** = TOWABLE WEIGHT

**B** = UNBRAKED TRAILER

**C** = LOAD ON TOW HOOK

| ENGINE                               | BODYWORK VERSION          |     | GVW                | A           | B   | C |
|--------------------------------------|---------------------------|-----|--------------------|-------------|-----|---|
| ALL                                  | MINIBUS / BASE<br>MINIBUS | ALL | 4005 / 4250 / 4300 | -           | -   | - |
| 2.2 140 HP H3-<br>Power with AdBlue® | Heavy                     |     | 4250 / 4300        | 2250 - 2200 | 750 | - |
| 2.2 180 HP H3-<br>Power with AdBlue® | Heavy                     |     | 4250 / 4300        | 2250 - 2200 | 750 | - |

NOTE For vehicles with tow hook: the vertical static load on the tow hook must be within the maximum permitted weight declared for the vehicle.

MAX (Maximum permitted weight + TOWABLE WEIGHT) = 6500 kg



## REFILLING

|   | 2.2 120 HP -140 HP -160 HP -180 HP<br>H3-Power with AdBlue® |              | Prescribed fuels and original lubricants   |
|---|---|--------------|--|
|   | Network   | Tempo Libero |  |
| Fuel tank (litres):                                   | 90 (*)  | 75 (**)      | Automotive Diesel<br>(EN590 specifications)  |
| Including a reserve of (litres):                      | 12  | 10 / 12      |  |
| UREA tank (where provided) approx. capacity (litres): | 19  | 19           | AdBlue® (water-UREA solution) standard DIN 70 070 and ISO 22241-1<br> 254) 255) |

(\*) A 75 litre tank is available on request for all versions (with reserve of 12 litres).

(\*\*) With the "Tempo Libero" option a 60 litre tank is available on request (with reserve of 9 litres).



### IMPORTANT

**254)** Use AdBlue® only according to DIN 70 070 and ISO 22241-1. Other fluids may cause damage to the system: also exhaust emissions would no longer comply with the law.

**255)** The distribution companies are responsible for the compliance of their product. Observe the precautions of storage and servicing, in order to preserve the initial qualities. The manufacturer of the vehicle does not recognise any guarantee in case of malfunctions and damage caused to the vehicle due to the use urea (AdBlue®) not in accordance with regulations.



|  | 2.2 120 HP -140 HP -160 HP -180 HP<br>H3-Power with AdBlue® | Prescribed fuels and original lubricants                       |
|--|---|--|
| Engine cooling system (litres):              | 10 (**)   | 50% mixture of distilled water and PARAFLU <sup>UP</sup> (***) |
| Engine sump (litres):                        | 5.4   | SELENIA WR FORWARD 0W-30                                       |
| Engine sump and filter (litres):             | 6.1   |  |
| Transmission/differential casing (litres):   | 2.2 (C637 transmission)                                     | TUTELA MTF 900   |
| Transmission/differential casing (litres):   | 2.9 (M40 transmission)                                      | TUTELA TRANSMISSION GEARTECH                                   |
| Automatic transmission casing AT9 (litres):  | 6.0   | TUTELA TRANSMISSION AS8  |
| Hydraulic braking circuit with ABS (kg):     | 0.6   | TUTELA TOP 4/S   |
| Hydraulic braking circuit with ASR/ESC (kg): | 0.62  |  |
| Windscreen/headlight washer reservoir:       | 5.5   | Mixture of water and liquid PETRONAS DURANCE SC 35             |

(\*\*) With Webasto: + 1/4 litre - Underseat heating 600 cc: + 1 litre - Underseat heating 900cc: + 1.5 litres - Underseat heating + Webasto: + 1.25 litres - Underseat heating + Webasto: +1.75 litres

(\*\*\*) When the vehicle is used in particularly harsh weather conditions, we recommend using a 60% mixture of PARAFLU<sup>UP</sup> and 40% demineralised water.

### WARNING

If it is necessary to top up the engine oil, strictly follow the procedure described in the “Engine oil” paragraph in the “Checking levels” chapter in the “Maintenance and care” section.

Top up with 0.2 litres at a time and then update the oil level on the display, every time. Do not add more oil if the level is not correctly updated. Make sure to NEVER exceed the maximum prescribed level.



## FLUIDS AND LUBRICANTS

Your vehicle is equipped with an engine oil that has been thoroughly developed and tested in order to meet the requirements of the Scheduled Servicing Plan. Constant use of the prescribed lubricants guarantees the fuel consumption and emission specifications. Lubricant quality is crucial for engine operation and duration.



### PRODUCT SPECIFICATIONS

| Use                      | Features                 | Specification      | Original liquids and lubricants   | Replacement frequency            |
|--------------------------|--------------------------|--------------------|---|----------------------------------|
| Diesel engine lubricants | <b>SAE 0W-30</b> ACEA C2 | <b>9.55535-DS1</b> | <b>SELENIA WR<br/>FORWARD 0W-30</b><br>Contractual Technical<br>Reference N° F842.F13 | According to Service<br>Schedule |

If lubricants conforming to the required specification are not available, products that meet the indicated specifications can be used to top up; in this case optimal performance of the engine is not guaranteed.

| Use   | Features  | Specification            | Original liquids and lubricants  | Replacement frequency  |
|---|---|--------------------------|--|--|
| Lubricants and greases for drive transmission | SAE 75W-70 API GL-4+ grade synthetic lubricant  | <b>9.55550-MZ14</b>      | <b>TUTELA MTF 900</b><br>Contractual Technical Reference N° F006.B21               | Mechanical transmission and differential (C637 transmission) |
|   | Synthetic lubricant SAE 75W-85 grade  | <b>9.55550-MZ3</b>       | <b>TUTELA TRANSMISSION GEARTECH</b><br>Contractual Technical Reference N° F704.C08 | Mechanical transmission and differential (M40 transmission)  |
|   | Synthetic lubricant   | <b>9.55550-AV5</b>       | <b>TUTELA TRANSMISSION AS8</b><br>Contractual Technical Reference N° F139.I11      | Lubricant for versions with AT9 automatic transmission       |
|   | Molybdenum disulphide grease, for use at high temperatures. Consistency NLGI 1-2                                | <b>9.55580 - GRAS II</b> | <b>TUTELA ALL STAR</b><br>Contractual Technical Reference N° F702.G07              | Wheel side constant velocity joints                          |
|   | Low friction coefficient grease for constant velocity joints. Consistency NLGI 0-1                              | <b>9.55580 - GRAS II</b> | <b>TUTELA STAR 700</b><br>Contractual Technical Reference N° F701.C07              | Differential side constant velocity joints                   |
| Brake fluid                                   | Synthetic fluid for brake and clutch systems. Exceeds specifications: FMVSS n° 116 DOT 4, ISO 4925, SAE J 1704. | <b>MS.90039</b>          | <b>TUTELA TOP 4/S</b><br>Contractual Technical Reference N° F005.F15               | Hydraulic brakes and hydraulic clutch controls               |



| Use  | Features  | Specification                     | Original liquids and lubricants   | Replacement frequency   |
|--|---|-----------------------------------|---|---|
| Protective agent for radiators                           | Red protective with antifreeze action, based on inhibited monoethyl glycol with organic formula.<br>Exceeds CUNA NC 956-16, ASTM D 3306 specifications. | <b>9.55523 or MS.90032</b>        | <b>PARAFLU<sup>UP</sup></b><br>Contractual Technical Reference N° F101.M01        | Cooling circuits. Use rate 50% up to -35°C. Mixture with different formulation products not allowed. (*)                        |
| Diesel fuel additive                                     | Additive for diesel antifreeze, protecting Diesel engines.  | -                                 | <b>PETRONAS DURANCE DIESEL ART</b><br>Contractual Technical Reference N° F601.L06 | To be mixed with diesel (25 cc per 10 litres)   |
| AdBlue <sup>®</sup> (UREA) additive for diesel emissions | Water-AdBlue <sup>®</sup> (UREA) solution   | <b>DIN 70 070 and ISO 22241-1</b> | <b>AdBlue<sup>®</sup> (UREA)</b>  | To be used for filling the AdBlue <sup>®</sup> (UREA) tank on vehicles equipped with Selective Catalytic Reduction (SCR) system |
| Windscreen washer fluid                                  | Mixture of spirits and surfactants. Exceeds the CUNA NC 956-II specification  | <b>MS.90043</b>                   | <b>PETRONAS DURANCE SC 35</b><br>Contractual Technical Reference N° F001.D16      | To be used neat or dilute in screen washer systems.   |

(\*) When the vehicle is used in particularly harsh weather conditions, we recommend using a 60% mixture of **PARAFLU<sup>UP</sup>** and 40% demineralised water.



**WARNING**

**95)** The use of products with specifications other than those indicated above could cause damage to the engine not covered by the warranty.

## FUEL CONSUMPTION AND CO<sub>2</sub> EMISSIONS

---

The fuel consumption and CO<sub>2</sub> emission figures declared by the manufacturer are determined on the basis of the type-approval tests laid down by the applicable standards in the country where the vehicle is registered.

The type of route, traffic situations, weather conditions, driving style, general conditions of the vehicle, trim level/equipment/accessories, climate control system, vehicle load, roof rack, other situations that affect aerodynamics or air drag may lead to different fuel consumption levels than those measured. The fuel consumption will only become more regular after driving the first 3000 km.

To find the specific fuel consumption and CO<sub>2</sub> emission figures for this vehicle, please refer to the data in the Certificate of Conformity, and the related documentation that accompanies the vehicle.



## **PRESCRIPTIONS FOR HANDLING THE VEHICLE AT THE END OF ITS LIFE**

---

The Manufacturer has been committed for many years to safeguarding the Environment through the constant improvement of its production processes and manufacturing products that are increasingly "eco-compatible". To grant customers the best possible service in terms of respecting environmental laws and in response to European Directive 2000/53/EC governing vehicles at the end of their life, the Manufacturer is offering its customers the chance to hand over their vehicle at the end of its life without incurring any additional costs. The European Directive sets out that when the vehicle is handed over, the last keeper or owner should not incur any expenses as a result of it having a zero or negative market value.

To hand your vehicle over at the end of its life without extra cost, contact one of our dealerships if you are purchasing another vehicle or a collection and scrapping centre authorised by the Manufacturer. These centres have been carefully chosen to offer high quality service for the collection, treatment and recycling of vehicles at their end of life, respecting the surrounding environment.

You can find further information on these collection and scrapping centres either from a Stellantis dealership or by calling the number in the Warranty Booklet or by consulting the websites of the various Stellantis brands.

## WHAT TO DO IF

| Fault  | Possible solution   |  |
|--|---|--|
| ... A TYRE IS PUNCTURED.   | Use the tyre repair kit   | See page 243.                              |
|  | Replace the tyre.   | See page 238.                              |
| ... A TYRE DEFLATES.   | Restore the correct pressure.   | See page 288.                              |
| ... THE INTERNAL CEILING LIGHT DOES NOT SWITCH ON.                               | Replace the bulb.   | See page 237 or contact a Fiat Dealership. |
| ... AN EXTERNAL BULB (high beam, dipped beam headlights, etc.) DOES NOT COME ON. | Replace the bulb.   | See page 232 or contact a Fiat Dealership. |
| ... THE REMOTE CONTROL DOES NOT WORK.  | Replace the batteries inside the remote control.  | See page 12 or contact a Fiat Dealership.  |
| ... AN ELECTRIC WINDOW DOES NOT WORK.  | Check the relevant protective fuse.   | See page 238 or contact a Fiat Dealership. |
|  | Have the relevant window raising / lowering motor checked.  | Contact a Fiat Dealership.                 |
| ... THE ENGINE DOES NOT START OR STOPS WHEN DRIVING.                             | Check that there is sufficient fuel in the tank; refuel if necessary.   | See page 210.                              |
|  | Use winter diesel fuel or a suitable additive.  | See page 308.                              |
| ...DIESEL FUEL IS FROZEN.  | In the case of VOR, warm up the diesel filter area and the upstream/downstream circuits, if possible.                       | -  |
| ...INCORRECT FITTING OF THE AFTER MARKET SYSTEMS.                                | Carefully follow the instructions in the Owner Handbook in order to prevent affecting the correct operation of the vehicle. | Contact a Fiat Dealership.                 |



| Fault   | Possible solution   |
|---|---|
| ...STEERING STUCK WITH VEHICLE STOPPED AND STEERING LOCK ENGAGED. | <p>If the vehicle is parked with the wheels completely steered, the steering wheel must be turned in the direction opposite to the end of travel position, while taking the key to MAR-ON.</p> <p style="text-align: right;">-</p>  |
| ... THE ENGINE DOES NOT START, THE STARTER DOES NOT TURN.         | <p>The battery might be empty, check its charge status. If necessary carry out the jump starting procedure.</p> <p style="text-align: right;">See page 246.</p>   |
|   | <p>The battery quick-release terminal might have disconnected, check the correct connection on the battery negative pole.</p> <p style="text-align: right;">-</p> <hr/> <p>The battery protection fuse might be broken. Avoid trying to force starting by persisting with the key in the AVV position. Do not connect any external loads to the battery.</p> <p style="text-align: right;">See page 238 or contact a Fiat Dealership.</p> |
| ... THE ENGINE DOES NOT START FOLLOWING AN IMPACT.                | <p>Fuel supply might be interrupted following activation of the fuel cut-off inertia switch. Check the system re-activation procedure.</p> <p style="text-align: right;">See page 249.</p>  |



# MULTIMEDIA



**Uconnect™**

*This section describes the main functions of the **Uconnect™** infotainment system that may be fitted on vehicle.*

|  |     |
|--|-----|
| TIPS, CONTROLS AND GENERAL INFO .....        | 316 |
| Uconnect™ .....                              | 318 |
| Uconnect™ 5" .....                           | 336 |
| CONNECTED SERVICES - UCONNECT SERVICES ..... | 346 |
| OFFICIAL TYPE APPROVALS .....                | 349 |



## TIPS, CONTROLS AND GENERAL INFO



256) 257)



96) 97)

### ROAD SAFETY

Learn how to use the various system functions before setting off.

Read the instructions for the system carefully before starting to drive.

### RECEPTION CONDITIONS

Reception conditions change constantly while driving. Reception may be interfered with by the presence of mountains, buildings or bridges, especially when you are far away from the broadcaster.

**WARNING** The volume may be increased when receiving traffic information and news.

### CARE AND MAINTENANCE



96) 96)

Observe the following precautions to ensure the system is fully operational:

- the display lens should not come into contact with pointed or rigid objects which could damage its surface; use a soft, dry anti-static cloth to clean and do not press;
- do not use alcohol, petrol and derived products to clean the display lens and make sure that the

**Uconnect™** system is switched off during cleaning;

- prevent any liquid from entering the system: this could damage it beyond repair.

### MULTIMEDIA DEVICES

**WARNING** Some multimedia players may not be compatible with the **Uconnect™** system.

Only use devices (e.g. USB flash drives) from safe sources on the vehicle.

Devices from unknown sources could contain software infected by viruses which, if installed on the vehicle, could increase the vulnerability of the electric/electronic systems of your vehicle to hacking.

### ANTI-THEFT PROTECTION

The system is equipped with an anti-theft protection system based on the exchange of information with the electronic control unit (Body Computer) on the vehicle.

This guarantees maximum safety and prevents the secret code from being entered after the power supply has been disconnected.

If the check has a positive outcome, the system will start to operate, whereas if the comparison codes are not the same or if the electronic control

unit (Body Computer) is replaced, the system will ask the user to enter the secret code according to the procedure described in the paragraph below.

### Entering the secret code

When the system is switched on, if the code is requested, the display will show "Please enter Anti-Theft Code" followed by the screen showing a keypad to enter the secret code.

The secret code is made up of four digits, from 0 to 9: press the corresponding key on the display to insert the first digits of the code.

After entering the fourth digit, the system begins operating.

If an incorrect code is entered, the system displays "Incorrect Code" to notify the user of the need to enter the correct code.

After the 3 available attempts to enter the code, the system displays "Incorrect Code. Radio locked. Please wait for 30 minutes". After the text has disappeared it is possible to start the code entering procedure again.

### WARNINGS

In the event of a fault, the system must only be checked and repaired by a Fiat Dealership.

If the temperature is particularly low, the display may take a while to reach optimum brightness.

If the vehicle is stopped for a while and the external temperature is very high, the system may go into "thermal protection" mode, suspending operation until the temperature in the radio returns to acceptable levels.

Look at the screen only and when it is necessary and safe. If you need to look at the screen for a long time, pull over to a safe place so as not to be distracted while driving.

Immediately stop using the system in the event of a fault. Otherwise the system might be damaged.

Contact a Fiat Dealership as soon as possible to have the system repaired.



### IMPORTANT

**256)** Follow the safety rules below: otherwise serious injuries may occur to the occupants or the system may be damaged.

**257)** If the volume is too loud this can be dangerous. Adjust the volume so that you can still hear background noises (e.g. horns, ambulances, police vehicles, etc.).



### WARNING

**96)** Only clean the front panel and the display with a soft, clean, dry, anti-static cloth. Cleaning and polishing products may damage the surface. Do not use alcohol or similar products to clean the control panel or the display.

**97)** Do not use the display as a base for supports with suction pads or adhesives for external navigators or smartphones or similar devices.

**98)** Do not use the display as a base for supports with suction pads or adhesives for external navigators or smartphones or similar devices.



# Uconnect™

## Uconnect™ 10"

(where provided)



# Uconnect™ 7”

(where provided)

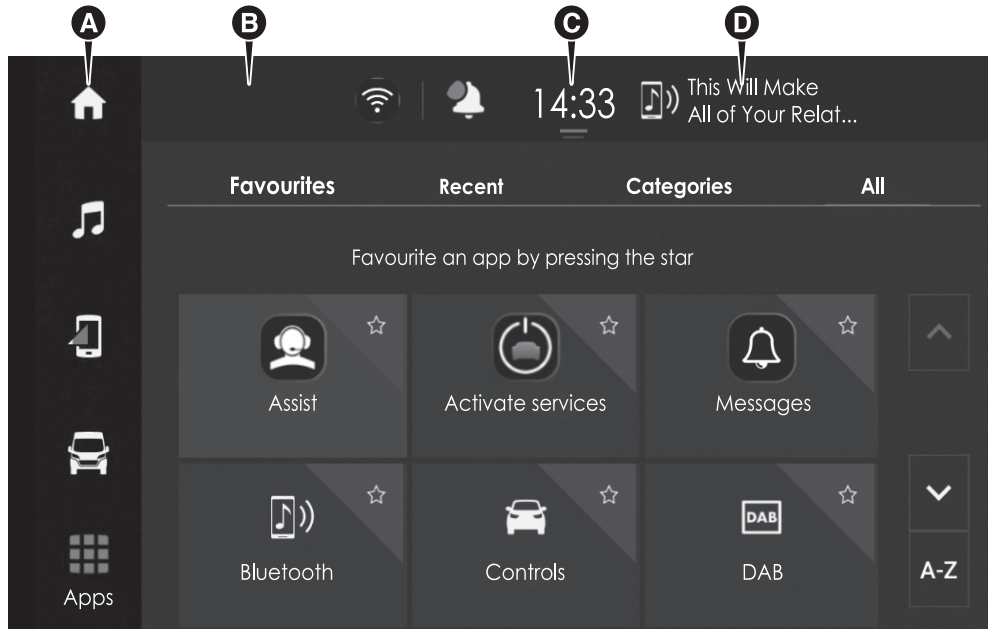







345

F1A0748



**GRAPHIC BUTTONS ON DISPLAY (A)**

| Graphic button   | Functions   | Mode                 |
|--|---|----------------------|
|  - Home                     | Show the main screen  | Press graphic button |
|  - Media                    | Access Media mode to select available sources, folder tracks and interaction with audio settings    | Press graphic button |
|  - Comfort (where provided) | Climate control system settings (air flow, set indoor temperature) and heated seat (where provided) | Press graphic button |
|  - Phone                    | Access to the Phone mode  | Press graphic button |
|  - Vehicle                  | Access to additional vehicle settings and functions   | Press graphic button |
|  - Nav (where provided)     | Start Navigation system   | Press graphic button |
|  - App                      | Access the list of available Apps   | Press graphic button |

You can customise the order of the buttons by holding down the icon to move and dragging it to the desired position.

NOTE Customisation is only active when the vehicle is stationary. If an attempt is made to customise with the vehicle in motion or to resume driving without having completed the operation, a warning message will appear on the display and the operation will be ended.

## STATUS BAR

| Area                              | Functions   | Mode                 |
|-----------------------------------|---|----------------------|
| B Reconfigurable quick button bar | Quick access to functions: Profiles (*), Notifications, External temperature, Voice recognition (*) | Press graphic button |
| C Timetable / App customisation   | Display the current time / access to the Apps list for customising the reconfigurable bar (**)      | Press graphic button |
| D Message area                    | Audio track playing, tuned radio station, call time, volume and scrolling messages                  | -                    |

(\*) If available

(\*\*) For versions or markets where provided



## STEERING WHEEL CONTROLS



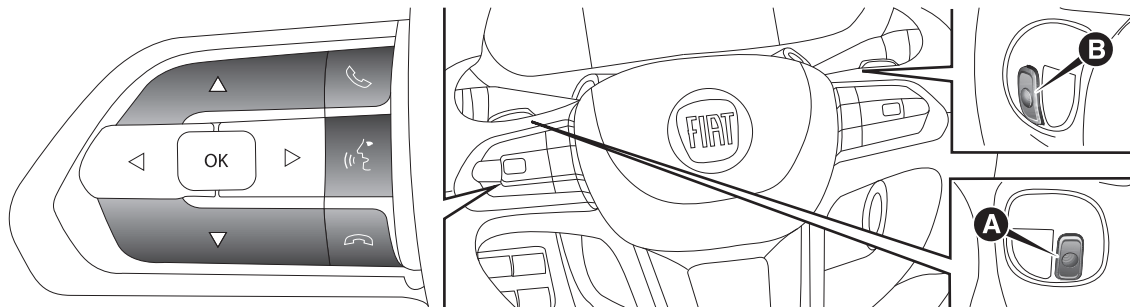

The controls for the main system functions are present on the steering wheel to make control easier.



346

F1A0729

### Steering wheel controls summary table

| Button  | Interaction   |
|---|---|
|  | <ul style="list-style-type: none"> <li><input type="checkbox"/> Acceptance of incoming call</li> <li><input type="checkbox"/> Acceptance of the second incoming call and putting the active call on hold</li> <li><input type="checkbox"/> Activation of voice recognition for phone functionality (where provided)</li> </ul>          |
|  | <ul style="list-style-type: none"> <li><input type="checkbox"/> Activation of voice recognition (where provided or via CarPlay or Android Auto)</li> <li><input type="checkbox"/> Interruption of the voice message in order to give a new voice command</li> <li><input type="checkbox"/> Interruption of voice recognition</li> </ul> |
|  | <ul style="list-style-type: none"> <li><input type="checkbox"/> Rejection of incoming call</li> <li><input type="checkbox"/> Ending of call in progress</li> </ul>  |
|  | <ul style="list-style-type: none"> <li><input type="checkbox"/> Short press (Phone mode): selection, on the instrument panel display, of the last calls/text messages (only with call browsing active) (where provided)</li> </ul>  |



## CONTROLS BEHIND THE STEERING WHEEL

| Buttons                                     | Interaction  |
|---|--|
| <b>Button A (steering wheel left side)</b>  |  |
| Upper button                                | <ul style="list-style-type: none"> <li><input type="checkbox"/> <i>Brief button press</i>: search for next radio station or selection of USB next track.</li> <li><input type="checkbox"/> <i>Long button press</i>: scan of higher frequencies until released/fast forward of USB track.</li> </ul> |
| Central button                              | <p>With each press advances between AM, FM, DAB, USB and <b>Bluetooth®</b> sources.<br/>Only the available sources will be selected.</p>   |
| Lower button                                | <ul style="list-style-type: none"> <li><input type="checkbox"/> <i>Brief button press</i>: search for next radio station or select USB previous track.</li> <li><input type="checkbox"/> <i>Long button press</i>: scan of lower frequencies until released/fast forward of USB track.</li> </ul>    |
| <b>Button B (steering wheel right side)</b> |  |
| <b>Increasing volume</b>                    |  |
| Upper button                                | <ul style="list-style-type: none"> <li><input type="checkbox"/> <i>Brief button press</i>: single volume increase</li> <li><input type="checkbox"/> <i>Long button press</i>: fast volume increase</li> </ul>  |
| Central button                              | Volume activation/deactivation (Mute/Pause)  |
| <b>Decreasing volume</b>                    |  |
| Lower button                                | <ul style="list-style-type: none"> <li><input type="checkbox"/> <i>Brief button press</i>: single volume decrease</li> <li><input type="checkbox"/> <i>Long button press</i>: fast volume decrease</li> </ul>  |



## CENTRAL DASHBOARD CONTROLS

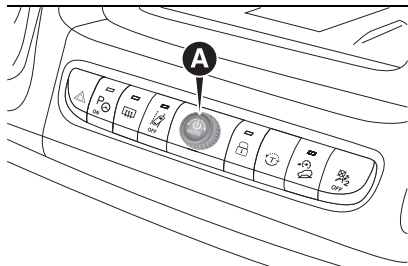

A button/knob (A) fig. 347 is provided on the dashboard that can be used as follows:

- Turn knob: increase/decrease volume
- Short press: **Uconnect™** on/off button
- Long press: "Mute" function on/off

## TOUCHSCREEN FUNCTION

The system uses the touchscreen function; to interact with the different functions, press the graphic buttons displayed.

**To confirm** the selection, press the graphic button "OK" or tick the required selection. Confirmation of some functions or settings is accompanied by a dedicated chime.

**To return to the previous screen** press "X" or "OK" or "Cancel" or "Yes" or anywhere outside the pop-up depending on the choice the system makes, or simply by selecting the desired icon on the display.

**To go back to the home screen or initial position** press the  graphic button.

The touchscreen function can be used to access and view the available lists of music tracks, phone numbers, settings, etc.

Move your finger on the screen to scroll lists and selections. Hold your finger down and move up to display the list items at the bottom; move down to display the list items at the top. Hold your finger down on the screen and move your finger rightwards, to see the lists to the left; move your finger leftwards, to see the lists to the right of the screen. The same operation can be performed to move between pages. Press your finger on the chosen field or button to select the field or perform the function associated with the button.

## HOT BUTTONS

Up to 2 hot buttons (3) fig. 344 can be set on the status bar.

Press the button below the time ((4) fig. 344) to open the drop-down menu with the list of available apps. Hold the desired app pressed and drag it to the app to be replaced on the status bar.

**NOTE** Customisation is only possible when the vehicle is stationary. If an attempt is made to customise with vehicle in motion or to resume driving without having completed the operation, a warning message will appear on the display and the operation will be ended.

## MEDIA MODE

Press the "Media" graphic button to listen and manage your music, view the available lists and select your preferred audio settings.

**WARNING** Applications used on portable devices may be not compatible with the **Uconnect™** system.

After Media mode is selected, the following information is shown on the display:

**Upper part:** Selection of the different pages of the function "Sources", "Playback", "Browse", "Audio settings".

**Left part:** Display of the user's three favourite sources. To choose the source, select "All sources" and then choose the source to display. The source being played is shown in red.

**Middle part:** Display of information about the track being played and playback control buttons:

"Bluetooth": for a **Bluetooth®** audio source, opens the list of devices;

"Browse" for **USB/Bluetooth®** source, allows you to search for content on your device;

"Tracks" for **USB/Bluetooth®** source, allows you to select a track from the playlist;

: previous/next track selection or previous/next station;

: random playback of the tracks contained in the folder;

: when the last track is finished, playback automatically resumes from the first track in the playlist;



: pause track being played;

 "Tuning": access the radio station selection page.

**Lower part:** Quick access to the favourite radio stations.

### Track selection

The "Tracks" function allows you to open a window with the list of tracks being played.

The graphic buttons  and  can be used to browse the list of artists, music genres and albums on the connected device via USB or **Bluetooth®**, according to the information recorded on the tracks themselves.

Within each list, the "ABC" graphic button allows the user to skip to the desired letter in the list.

NOTE This button might be disabled for some **Apple** devices.

NOTE The DAB frequency can be used in countries where digital transmission technology is available. The device will be tuned to any frequency if the DAB button is pressed in a country where the service is not provided.

### COMFORT MODE

(where provided)

On the screen you can select:

the airflow distribution settings: windscreen, face, face plus feet, feet plus windscreen;

the inside temperature settings;

the defrosting of the rear window ();

the activation of the climate control system (A/C);

the activation of the climate control system with maximum cooling (Max A/C);

- the recirculation function;
- the AUTO function;
- the activation/deactivation of the heated seat function (where provided).

### BLUETOOTH® MODE

This mode is activated by pairing a **Bluetooth®** device containing music tracks with the **Uconnect™** system.

### PAIRING A BLUETOOTH® AUDIO DEVICE

The pairing of a **Bluetooth®** device (e.g. a smartphone) is done via the "Device Manager" function on the "Phone" page.

Proceed as follows to pair a device:

activate the **Bluetooth®** function on the device;

access the "Device Manager" function;

press the "Add Device" button;

a pop-up window shows the temporary PIN to be entered on the device;

search for **Uconnect™** on the **Bluetooth®** audio device;

when requested by the audio device, enter the PIN code shown on the system display or confirm on the device the PIN displayed;

if the pairing procedure is completed successfully, a screen is displayed. Answer "Yes" to the question to pair the **Bluetooth®** audio device as



favourite (the device will have priority over all other devices to be paired subsequently). If "No" is selected, the priority is determined according to the order of connection. The last device connected will have the highest priority. If no device has been registered, you can access the "Device Manager" directly from the "Phone" function.

**NOTE** Up to 20 device can be paired. In case of an attempt to pair a twenty-first device a pop-up window will notify that this is impossible. Remove a paired device to allow the pairing of a new one.

**NOTE** The Radio may change the track being played by modifying the from name of the device in the **Bluetooth®** settings of the telephone (where provided), if the device is by means of USB after the **Bluetooth®** connection. After updating the phone software, for proper operation, it is recommended to remove the phone from the list of devices linked to the radio, delete the previous system pairing also from the list of **Bluetooth®** devices on the phone and make a new pairing.

**WARNING** If the **Bluetooth®** connection between mobile phone and system is lost, consult the mobile phone handbook.

## USB SOURCE

There are two USB ports: the first is located on the dashboard for charging external devices only, the second is in the lower part of the dashboard for transferring data to the **Uconnect™** system and for charging external devices.

When a USB device is plug into the port on the dashboard with the radio on, it starts to play the tracks on the device if the "AutoPlay" is set to "ON" in the "Audio" menu. If the "AutoPlay" function is set to OFF and a smartphone is connected, only charging the device will be active.

## PHONE MODE

Press the "Phone" button on the display to activate the Phone mode.

**NOTE** To consult the list of mobile phones and functions supported, contact Customer Care on the number provided in the Warranty or visit the [www.uconnectphone.com](http://www.uconnectphone.com) website.

Select the desired page on the display using the bar at the top to:

dial the phone number using the graphic dial pad on the display;

**NOTE** The keypad is only active when the vehicle is stationary. If an attempt is made to use the keypad with the vehicle in motion or if driving is resumed without having completed

engagement, a warning message will appear on the display and the operation will be ended.

- display and call contacts from the registers of previous calls;
- display and call the contacts in the phonebook of the mobile phone;
- view received text messages;
- view the connected devices.

The mobile phone audio is transmitted through the sound system of the vehicle; the system automatically mutes the **Uconnect™** system audio when the Phone function is used.

## Pairing a mobile phone

**WARNING** Carry out this operation only with vehicle stationary and in safety conditions; this function is deactivated when the vehicle is moving.

To pair a mobile phone, see the procedure in "Pairing a Bluetooth® audio device" in this chapter.

## "Double telephone" feature

The **Uconnect™** system allows simultaneous **Bluetooth®** connection to two telephones. Only one of the two connected devices can play multimedia content via **Bluetooth®**.

**WARNING** The "double telephone" feature is not available while using the

telephone in CarPlay or Android Auto mode.

## Making a phone call

The operations described below can only be accessed if supported by the mobile phone in use. For all functions available, refer to the mobile phone owner's handbook.

You can make a call by selecting one of the following items:

- "Keypad"
- "Recent"
- "Favourites"
- "Contacts"

## Favourites

You can add a number or a contact (if already in Contacts) to the favourite list during a call by pressing the star by the side of the contact/number. The favourites can also be managed by using the menu options.

## Text Message Reader

(where provided)

The system can read the messages received by the mobile phone. To use this function, the mobile phone must support the text exchange function through **Bluetooth®**.

If this operation is not supported by the phone, the corresponding "Text message" graphic button is deactivated (greyed out).

When a text message is received, the display will show a screen where the options "Read", "Show", "Call" or "Ignore" can be selected.

You can access the text message list received by the cell by selecting the "Messages" item (the list shows a maximum of 60 received messages).

NOTE On some mobile phones, to make the text voice reading function available, the text notification option on the phone must be enabled; this option is usually available on the phone, in the **Bluetooth®** connections menu for a device registered as **Uconnect™**. After enabling this function on the mobile phone, it must be disconnected and reconnected with the **Uconnect™** system in order to make it effective.

WARNING Some mobile phones may not take the text message delivery confirmation settings into account when interfacing with **Uconnect™**.

If a text message is sent via the **Uconnect™** system, the driver could face an additional cost, without any warning, due to the text message delivery confirmation request sent by the phone. For any problems related to the above, contact your telephone service provider.

## "Do Not Disturb" function

If supported by the connected phone, by pressing the "Do Not Disturb" graphic button the user will not receive notifications of incoming calls or text messages. The user can reply with a default or customized message by means of the settings.

## Text message options

(where provided)

Predefined messages are stored in the system memory and can be sent to answer a received message or as a new message:

- Yes
- No
- Okay
- I can't talk right now
- Call me
- I'll call you later
- I'm on my way
- Thanks
- I'll be late
- Stuck in traffic
- Start without me
- Where are you?
- Are you there yet?
- I need directions
- I'm lost
- See you later
- I will be 5 (or 10, 15, 20, 25, 30, 45, 60) (\*) minutes late



▣ See you in 5 (or 10, 15, 20, 25, 30, 45, 60) (\*) minutes

(\*) Only use the numbers listed, otherwise the system will not take the message. When receiving a text message, the systems also allows the same message to be forwarded.

NOTE For details on how to send a text message using the voice commands, refer to the dedicated paragraph.

## Apple CarPlay and Android Auto

(where provided)

The Apple CarPlay and Android Auto applications allow you to use your smartphone in the vehicle safely and intuitively. To enable them, connect a compatible smartphone to the vehicle USB port or in Wireless mode, and the contents of the phone will be automatically shown on the **Uconnect™** system display.

To check the compatibility of your smartphone, refer to the indications on the websites:

[https://www.android.com/intl/it\\_it/auto/](https://www.android.com/intl/it_it/auto/)  
<http://www.apple.com/it/ios/carplay/>.

If the smartphone is connected correctly to the vehicle via the USB port or in Wireless mode, the Apple CarPlay or Android Auto icon will be displayed in place of the  graphic button in the main menu.

NOTE The date and time shown on the **Uconnect™** system display must match the actual date and time, even after disconnecting the battery. Adjust it from the "Settings" menu of the **Uconnect™** system. Any discrepancy between the date and time on the display and the actual date and time may be due to a malfunction in Apple CarPlay/Android Auto.

### Apple CarPlay App Setup

Apple CarPlay is compatible with the iPhone 5 or more recent models, with the iOS 7.1 operating system or later versions.

Before using Apple CarPlay, enable Siri from "Settings" > "General" > "Siri" on the smartphone.

### Android Auto APP Setup

Before use, download the Android Auto application to your smartphone from Google Play Store.

The application is compatible with Android 5.0 (Lollipop) and later versions. Starting from Android version 10 and higher, the Android Auto app is integrated into the operating system of the smartphone and no downloading is required.

On the first connection, you will have to perform the setup procedure that appears on the smartphone. You can

only perform this procedure with the vehicle stationary.

Once connected to the USB port, the Android Auto application establishes a parallel **Bluetooth®** connection.

### Wireless mode

You can use Apple CarPlay and Android Auto in Wireless mode, without the need to connect your smartphone to the USB port.

To configure this mode, follow the procedure for pairing a **Bluetooth®** device. If successfully completed and the connected device supports Wireless mode, confirm that it starts on the message shown on your smartphone and **Uconnect™** display. On subsequent connections, Wireless mode is available automatically. If a **Bluetooth®** pairing is cancelled, the pairing procedure must be repeated on the "Device Manager" menu.

### Interaction

After the setup procedure, the application will run automatically on the **Uconnect™** system when your smartphone is connected to the USB port in the vehicle.

▣ *Apple CarPlay*: To interact with Apple CarPlay press the steering wheel button  (long press) or the "Home" graphic button on the display in Apple CarPlay.

❑ **Android Auto:** To interact with Android Auto press the steering wheel button  (long press of the button) or the "Microphone" graphic button on the display in Android Auto (where provided).

## Navigation

(where provided)

If the "Nav" mode of the system is already active, or when a device is connected to the vehicle with a navigation session in progress, the system navigation mode is interrupted to continue the navigation session of the device.



The selection can be changed at any time by accessing the chosen navigation system and setting a new destination.

## Exiting the Android Auto and Apple CarPlay apps

To end the Apple CarPlay or Android Auto session, physically disconnect the smartphone from the USB port of the vehicle or using the "Device Manager" menu.

## VOICE COMMANDS

NOTE Voice commands are not available for languages not supported by the system.

To use voice commands, press the "Voice"  button on the steering wheel controls or the green button 

or the button  on the display (where provided) and say out loud the function you want to activate. Alternatively, where supported, the function can be activated by saying "Hey Fiat" or "Hey Uconnect" (if the user has previously enabled the function).

The list of available voice commands is shown on the display divided by categories.

## Suggestion

A list of the most used voice commands is shown.

## Phone

- ❑ Call *<contact name>*
- ❑ Call *<number>*
- ❑ Write message
- ❑ Call back
- ❑ Show recent calls
- ❑ Show outgoing calls
- ❑ Show missed calls
- ❑ Show received calls

## Text

❑ Send a message to *<contact>* mobile / work

## Media

- ❑ I want to listen to music
- ❑ Play *<track>* by *<artist>*
- ❑ Let me hear some *<genre>*
- ❑ Show my playlists
- ❑ Play album...
- ❑ Play artist...
- ❑ Play genre...
- ❑ Play playlist...

## Radio

- ❑ I want to listen to music
- ❑ Play *<track>* by *<artist>*
- ❑ Let me hear some *<genre>*
- ❑ Show my playlists
- ❑ I want to listen to a radio
- ❑ Play radio *<name>*
- ❑ Play channel *<number>*
- ❑ Tune to *<frequency>* *<FM>/<AM>*
- ❑ Tune to *<radio name>*
- ❑ Tune to *<radio name>* DAB channel

## Navigation

See the "Navigation" paragraph below.

## Climate

- ❑ Set the temperature to *<value>*
- ❑ I'm cold
- ❑ Make it warmer
- ❑ Turn down the fan
- ❑ Turn on the A/C



## NAVIGATION

(where provided)

Press the "Nav" graphic button to show the navigation map on the display.

You can use map view in the same way as you might look at a traditional paper map. You can move around the map using gestures, and zoom using the zoom buttons.

You can find your destination by selecting it on the map, choosing a saved destination (for example "Home" or "Work") or searching for an address using the "Search" button in the main menu.

After selecting the destination, a route is planned and shown on the "Map view" screen. The route bar appears on the right hand side of the display and provides an additional indication of events along the route, e.g. accidents and speed cameras. The arrival time and remaining distance are also available.

You can choose to view the route via a 3D image in the "Guidance view".

NOTE The navigation system volume can only be adjusted during navigation when the system provides voice indications.

NOTE In some countries, the use of the keyboard is only permitted when the vehicle is stationary. If an attempt is made to enter text (e.g.

an address) with vehicle in motion or if driving is resumed without having completed engagement, a warning message will appear on the display and the operation will be ended.

We recommend the use of voice commands while driving.

### Navigation main menu

In "Map view" or "Guidance view", tap the "Main menu" button  to open the menu.

The following buttons are available in the main menu:



"Search": select this graphic button to search for an address, a place or a point of interest, then plan a route to the location.



"Drive Home": Select this button to navigate to the location registered as "Home". If this button is displayed as "Add Home", select this button to set the location of your home.



"Drive to work": Select this button to navigate to the location registered as "Work". If this button is displayed as "Add Work", select this button to set the work position.



"Recent": Select this button to open the list of recent destinations. Select a recent destination to plan a route to that destination.



"Favourites": select this button to show the saved favourite places.



"Trips": select this button to show saved trips.



"Maps": select this button to display a list of installed maps. The maps are updated automatically.



"Settings": select this button to open the Settings Menu. In the "Settings" menu, you can change the items shown on the navigation display.

### System buttons

The following buttons are available on the different screens of the navigation system:



After selecting a destination, clicking on a point on the map or using the search function, select this button. The navigation system will find the



best route and, if available, two alternative routes. You can select an alternative to avoid tolls or heavy traffic, for example.



Use this button to decide whether to display the results on the map or in a list.



Use this button to access the "Route Options" menu. With an active route, you can change the route from this screen.



Select this button to return to the previous screen.



Select this button to return to the "Map view" screen.



Select this button to switch between the "3D direction up", "2D direction up" and "2D north up".



Select this button to choose between audio instructions, warning only or no sound.

## Map update

To ensure optimal performance, the navigation system must be updated periodically.

The updates can be downloaded from the [maps.mopar.eu](http://maps.mopar.eu) website and installed directly on the **Uconnect™** system.

Map updates are included for the first 3 years, with the possibility of further renewals: more information is available at [maps.mopar.eu](http://maps.mopar.eu).

The navigation system can also be updated at the Fiat Dealership.

**NOTE** The dealer may charge for updating the navigation system.

## Voice Commands

**NOTE** Voice entry of addresses is only supported in the country in which you are located and provided that the system language matches the local language. For example, if the vehicle is located in Italy, it will be possible to enter Italian addresses only if the system language is set to "Italian".

The following voice commands can be given after pressing the button on the steering wheel :

- Find "POI" (Point of Interest)
- Go to "address"
- Go to "city name" centre

- Drive towards a town centre
- Navigate home
- Go via home
- Clear route
- Recent Destinations
- Stop at a recent destination
- 2D view
- 3D view

## Volume adjustment

The volume of the navigation system can only be adjusted when the navigation system provides voice commands.

## VEHICLE MODE

Pressing the "Vehicle" graphic button to access the pages: "Controls" and "Settings".

## Checks

The "Controls" label contains for example: screen on/off, electrochromic internal mirror (where provided), rear camera.

## Settings

The settings are available with the ignition device at MAR. You can access the settings in two ways by pressing the "Settings" button on the status bar, or from the main page of the function you are viewing, at the top right.  
**NOTE** The menu items displayed vary according to the versions.



The menu is indicative and includes the following items:

- Personal profile
- Language
- Display
- Units
- Safety and Driving Assistance
- Date and Time
- Phone/**Bluetooth®**
- Camera
- Mirrors and Windscreen Wipers
- Lights
- Brakes (where provided)
- Doors & Locks
- Vehicle switch off options/OFF status
- Audio/Audio Settings
- Radio Setup
- Geolocation
- Software update
- System information
- Restore

## APP

Pressing the graphic button "App" will display the "Favourites", "Recent", "Other categories" and "All" submenus.

### Favourites

The "Favourites" submenu contains (for versions/markets, where provided) the "Electrical functions" and "Performance" pages.

The "Favourites" page can contain up to 6 favourite pages. A message will indicate that you have reached the

maximum number of pages allowed if you try to add an additional page.

To add or remove an app from the Favourites list, select or deselect the star that appears on the app icon in the list shown in the "Recent", "Categories" or "All" pages. A pop-up will tell you whether you want to save the app in your favourites or not. The operation can be cancelled by selecting "Cancel" or "X".

### Recent

The "Recent" submenu contains recently used or downloaded apps. The user will see a list of apps arranged in chronological order. In the "Recent", "Categories" and "All" submenus you are prompted by a message to press the star on the App icon to add it to your favourite app list.

### Other categories

The "Other categories" submenu contains the list of filtered categories between apps. The following are displayed in order: Media, Clima (where provided), Nav (where provided), Telephone, Vehicle, System and more. The applications in each category are displayed in alphabetical order.

### All

The "All" submenu all available apps and allows the user to search for them

in alphabetical order from A to Z or Z to A.

## WIDGETS

On the main page, you can view summary pages of **Uconnect™** system functions (called "widgets") from a list of available widgets. To add a Widget, press the button  on the display and select the desired Widget from the list.

Some Widgets can also be customised by pressing the button  next to the title. This will open the customisation screen.

The number of Widgets which can be installed per page depends on their size. You can add multiple pages (up to a maximum of five in total) by pressing the "+" button on the display. To switch between pages, simply touch the page briefly and swipe your finger rightwards or leftwards.

Pages can be deleted using the "Delete page" function or reordered using the "Reorder pages" function.

NOTE Customisation is only active when the vehicle is stationary. If an attempt is made to customise with the vehicle in motion or to resume driving without having completed the procedure, a warning message will appear on the display and the operation will be ended.

## MOVING THE WIDGETS

Select the desired widget and then:



**Moving the widget:** hold the desired widget pressed for a few seconds and then move it to the right or left of the display.



**Resizing the widget:** press the widget resize icon to be resized.



**View widget content:** select the desired widget and then scroll vertically. When reordering the widgets (viewing their thumbnails), it will not be possible to view their contents.

## PROFILES

(where provided)

By entering the Profiles environment you can create an avatar and enter your own customisations.

Selecting "All profiles" displays all existing profiles. Up to 5 different profiles can be saved. Profiles can be deleted in bulk using the "Delete personal data" function in the "Settings" menu.

To create your profile select "Create profile" and type in the name of your choice, choose one of the available avatars and store the car seat you normally occupy.

You can exclude all profiles and keep the default settings by pressing on the "Valet" mode, using the button on the "All profiles" page.

After changing the profile, it may take up to about 5 minutes for the respective settings to load on the **Uconnect™** system, according to the version.

## UPDATING THE SYSTEM

The **Uconnect™** system can be updated remotely via Over The Air upgrade.

NOTE The images are given by way of example only. They may differ from those shown below according to the version/market.

NOTE Instead of using external Wi-Fi connections, Over The Air software updates use the data connectivity included with vehicle, at no additional cost to the customer.

When a software update is available, a pop-up window will appear on screen informing that a new software version or new features for the **Uconnect™** system are available.

WARNING The settings of the vehicle or phone settings may be lost after an Over The Air software update. Check and re-enter missing system settings, if necessary.

WARNING Some automatic system updates could take place during a phase of non-use, with the engine off. This might make it necessary to turn the ignition device from STOP to MAR and vice versa multiple times to restore all the audio and video operations.

NOTE The rear-view camera, **Uconnect™** system and other driver assistance systems are not available during the update. It is recommended to carry out the update when the vehicle is stationary.



## Instant update

Press the "Update Now" button fig. 348 to update the software immediately when the pop-up window appears on screen.

## Scheduled update

In case of a mandatory update, press the "Update now" or "Schedule update" button fig. 348. The scheduled update option allows you to define a different update time. Press the arrows  $\triangle/\nabla$  on the screen to set the desired time.

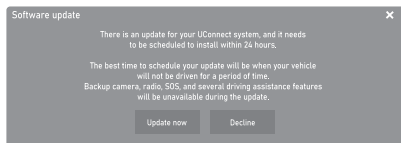

348

F1A0758

NOTE The scheduled update option can be used 20 times per update. After the 20th postponement the update will be made mandatory when the vehicle is first started. In case of a mandatory update you can only press the "OK" button on the pop-up and start the update.

During the update the radio will show the percentage of the update completed and the time remaining until completion fig. 349. When the update is complete the **Uconnect™** system will automatically restart.

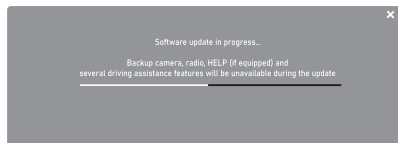

349

F1A0759

## Updates over external Wi-Fi

When a software update via Wi-Fi is available, a pop-up window will appear on the screen offering the update instantly or at a later time.

NOTE The rear-view camera, **Uconnect™** system and other driver assistance systems are not available during the update. It is recommended to carry out the update when the vehicle is stationary.

To allow the **Uconnect™** system to update its software:

- Select "Settings" on the screen
- Select "Wi-Fi" in the settings list

Select the correct Wi-Fi router from those shown  
NOTE If the Wi-Fi router is too far from the vehicle, it will not be shown among the available ones.

If prompted, enter the password to access the router and select "OK".

To enable software updates:

Select "Enable software download over Wi-Fi" on the Wi-Fi settings screen.

When a software update is available, a pop-up window will appear on the **Uconnect™** system screen to alert you that a new update is available. When asked to connect to a Wi-Fi network, select "Yes".

During the update, a second pop-up screen shows the estimated time remaining and the progress percentage of the update. When the update is finished, press "OK".

## Instant update

When the pop-up window appears on screen, press the "Update Now" button to update the software immediately.

## Scheduled update

Use the scheduled update option to set a deferred update time. Press the arrows  $\triangle/\nabla$  on the screen to set the desired time.

NOTE The scheduled update option can be used 20 times per update. After

the 20th postponement the update will be made mandatory when the vehicle is first started. In case of a mandatory update you can only press the "OK" button on the pop-up and start the update.

During the update the radio will show the percentage of the update completed and the time remaining until completion fig. 349. When the update is complete the **Uconnect™** system will automatically restart.

### Update errors

In case of errors during the update, the operation will be interrupted and the following messages will appear:

- ❑ "An error has occurred. The system will revert to the previous software version."
- ❑ "Update failed. - An error was detected during the update procedure. Call assistance. Error code: XXXX"  
Contact a Fiat Dealership in these cases.









# Uconnect™ 5”

## CONTROLS ON FRONT PANEL



## FRONT CONTROL PANEL SUMMARY TABLE

| Button   | Functions  | Mode                        |
|--|--|-----------------------------|
| <b>RADIO</b>   | Source selection: AM, FM, DAB (where provided)   | Brief button press          |
| <b>MEDIA</b>   | Source selection: USB, <b>Bluetooth®</b> audio   | Brief button press          |
|  | Volume on/off (MUTE)   | Brief button press          |
| <b>VOL</b>   | Switching the system on  | Brief button press          |
|  | Switching the system off   | Long button press           |
|  | Volume adjustment  | Left/right rotation of knob |
|  | Activation/deactivation of Play (playback) / Pause function  | Brief button press          |
|  | <b>Radio source:</b> Select the radio station stored under "Preset 1"<br><b>Media source:</b> On/Off random playback of tracks in the device | Brief button press          |
|  | <b>Radio source:</b> Store the radio station currently playing under "Preset 1"  | Long button press           |
|  | <b>Radio source:</b> Select the radio station stored under "Preset 2"<br><b>Media Mode:</b> Select the previous track                        | Brief button press          |
|  | <b>Radio source:</b> Store the radio station currently playing under "Preset 2"<br><b>Media Source:</b> Fast backward track playback         | Long button press           |
|  | USB port   | -                           |
|  | <b>Radio source:</b> Select the radio station stored under "Preset 3"<br><b>Media source:</b> Select the next track                          | Brief button press          |
|  | <b>Radio source:</b> Store the radio station under "Preset 3"<br><b>Media source:</b> Activate quick search function                         | Long button press           |



| Button                  | Functions   | Mode                        |
|-------------------------|---|-----------------------------|
| 4 ↻                     | <b>Radio source:</b> Select the radio station stored under "Preset 4"<br><b>Media source:</b> On/Off repeat tracks in USB device  | Brief button press          |
|                         | <b>Radio source:</b> Store the radio station currently playing under "Preset 4"   | Long button press           |
| ⚙                       | Access the settings menu  | Brief button press          |
|                         | Confirmation of the option displayed<br>Open browsing list (Radio or Media mode)  | Brief button press          |
| <b>BROWSE<br/>ENTER</b> | Scrolling the list or tuning to a radio station<br>Display list of stations (Radio mode)<br>Scroll contents of sources (Media mode)<br>Media source track change<br>Station change (RADIO mode) | Left/right rotation of knob |
| ↶                       | Exit the selection/return to previous screen  | Brief button press          |
| 📞 <b>PHONE</b>          | <input type="checkbox"/> Phone mode selection and acceptance of incoming phone call<br><input type="checkbox"/> Acceptance of the second incoming call and putting the active call on hold      | Brief button press          |
|                         | <input type="checkbox"/> Rejection of incoming call<br><input type="checkbox"/> Ending of call in progress  | Brief button press          |



## STEERING WHEEL CONTROLS

The controls for the main system functions are present on the steering wheel to make control easier.

The activation of the function selected is controlled, in some cases, by how long the button is pressed (short or long press) as described in the table below.

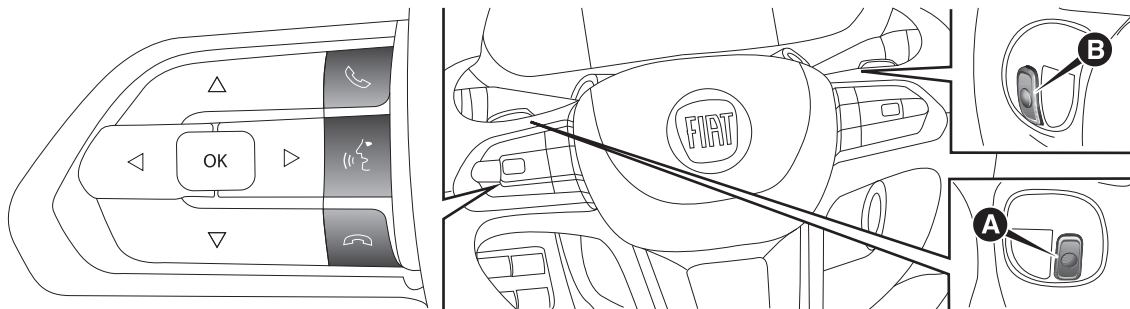



351

F1A0755



**STEERING WHEEL CONTROLS SUMMARY TABLE**

| Button  | Interaction  |
|---|--|
|  | <ul style="list-style-type: none"><li><input type="checkbox"/> Acceptance of incoming call</li><li><input type="checkbox"/> Acceptance of the second incoming call and putting the active call on hold</li></ul>   |
|  | <ul style="list-style-type: none"><li><input type="checkbox"/> Activation of "Siri" function recognition (if present) or voice assistant</li><li><input type="checkbox"/> Brief press: interruption of the voice message in order to give a new voice command (applies to "Siri"); for "Google": close voice session</li><li><input type="checkbox"/> Long press: voice recognition interruption</li></ul> |
|  | <ul style="list-style-type: none"><li><input type="checkbox"/> Rejection of incoming call</li><li><input type="checkbox"/> Ending of call in progress</li></ul>  |

## CONTROLS BEHIND THE STEERING WHEEL

| Buttons                                     | Interaction   |
|---|---|
| <b>Button A (steering wheel left side)</b>  |   |
| Upper button                                | <ul style="list-style-type: none"> <li><input type="checkbox"/> <i>Short press</i>: next radio station search / next preset (according to the "Steering Wheel Seek Buttons" setting) (Radio source), next song selection (Media source)</li> <li><input type="checkbox"/> <i>Long button press</i>: scan of higher frequencies until released/fast forward of USB track</li> </ul>          |
| Central button                              | With each press it scrolls through sources AM, FM, DAB, USB. Only the available sources will be selected.   |
| Lower button                                | <ul style="list-style-type: none"> <li><input type="checkbox"/> <i>Short press</i>: search previous radio station / previous preset (according to the "Steering Wheel Seek Buttons" setting) (Radio source), select previous song (Media source)</li> <li><input type="checkbox"/> <i>Long button press</i>: scan of lower frequencies until released/ fast forward of USB track</li> </ul> |
| <b>Button B (steering wheel right side)</b> |   |
| Upper button                                | <p><b>Increasing volume</b></p> <ul style="list-style-type: none"> <li><input type="checkbox"/> <i>Brief button press</i>: single volume increase</li> <li><input type="checkbox"/> <i>Long button press</i>: fast volume increase</li> </ul>   |
| Central button                              | Activation/deactivation of Mute function  |
| Lower button                                | <p><b>Decreasing volume</b></p> <ul style="list-style-type: none"> <li><input type="checkbox"/> <i>Brief button press</i>: single volume decrease</li> <li><input type="checkbox"/> <i>Long button press</i>: fast volume decrease</li> </ul>   |



**SYSTEM ON / OFF**

The system is switched on by briefly pressing the VOL button/knob on the front panel.

The system is switched off by long pressing the VOL button/knob on the front panel.

**RADIO MODE SELECTION**

To activate the Radio mode press the RADIO button on the front panel. The display will show the active frequency mode (AM, FM or DAB - for versions/markets, where provided).

**SELECTING A FREQUENCY BAND**

Briefly press the RADIO button on the front panel to select the desired frequency band.

**INFORMATION ON THE DISPLAY**

After the desired radio station is selected, the following information is shown on the display:

*In the upper part:* currently selected frequency band display (AM, FM or DAB - for versions/markets, where provided).

*In the central part:* display name (if available), frequency and storage number (within the list of favourite radio stations) of the listening radio station.

*In the lower part:* display additional information (if available) of the radio station you are listening to.

**FM station list**

Press the BROWSE ENTER button/knob to display the complete list of the FM stations that can be received.

**SETTING THE PRESETS**

The preset stations are available in all system modes and are selected by touching one of the presetting buttons **1-2-3-4** on the front panel.

If you are tuned to a radio station that you wish to store, hold down the button on the display which corresponds to the desired preset.

**RADIO STATION SELECTION**

To search for the desired radio station as follows:

- press the BROWSE/ENTER button/knob to access the Radio menu;
- select "Available Stations";
- turn the BROWSE ENTER button/knob clockwise or anticlockwise;
- press the BROWSE ENTER button/knob to confirm.

**Selecting a DAB radio category**

To select one of the DAB radio categories activate the "Browse" menu

for the DAB function and then select one of the following options:

- "Preset": this displays the list of stored presets;
- "Available Stations": this displays the list of available DAB stations;
- "Genres": to search for a category by choosing from the various available genres.

**RADIO STATION ALPHABETIC SELECTION**

Using the "ABC Jump" function, you can, according to the selected letter, position yourself alphabetically on the first of the available FM or DAB (for versions/markets, where provided) stations for that letter.

**SEARCH FOR STORED RADIO STATION**

Press buttons **2** ◀◀ or **3** ▶▶ on the front panel briefly: when released, the station stored under buttons **2** or **3** respectively is displayed.

When searching by turning the BROWSE/ENTER button/knob, if the system reaches the last station after scanning the entire band, it will automatically stop on the station from which the search started.

**PREVIOUS / NEXT RADIO STATION FAST SEARCH**

Press the buttons of Button A of the steering wheel controls (if the

Frequency Search option is selected in Settings) to perform the quick search: when the buttons are released, the first tunable radio station is played.

## MEDIA MODE

A dedicated messages will appear on the display if no Media device is connected to the system or if the connected Media source is not recognised by the system.

NOTE Audio from the **Bluetooth®** connected device does not play in RADIO (AM, FM or DAB) modes, only in **Bluetooth®** MEDIA mode.

## CHANGE TRACK (next/previous)

Turn the BROWSE ENTER button/knob clockwise to play the next track turn the BROWSE ENTER button/knob anticlockwise to go back to the beginning of the selected track or to the beginning of the previous track if the current one has been playing for less than 3 seconds.

NOTE The BROWSE/ENTER knob is not supported by Apple devices connected via USB.

Short press button 3 ►► to play the next track.

Short press button 2 ◀◀ to play the previous track.

## SONG FAST FORWARD

Long press button 3 ►► to fast-forward the selected song.

Long press button 2 ◀◀ to quickly reverse the selected song.

## SHUFFLE

Press button 1 𐄂 on the front panel to play the tracks on USB or **Bluetooth®** in a random order.

## REPEAT

Press button 4 ↺ to activate the function.

The following functions are available:

- "Repeat all": repeat all songs;
- "Repeat one": repeat the single song;
- "Repeat off": deactivate the function.

## USB MODE

To activate the USB mode, insert a USB flash drive into the USB port on the front panel. The display will show the first track available in play.

Press the BROWSE/ENTER button to open the following:

- All tracks
- Artists
- Albums
- Genres
- Playlists
- Podcasts (Apple devices only)
- Audiobooks (for Apple devices only)

## ❑ Folders

Turn the BROWSE ENTER button/knob to select the desired option and then press the button/knob to confirm the selection.

NOTE If you insert a USB flash drive into the port on the front panel, if the "Autoplay" function is ON, all files in all folders will be played automatically.

WARNING After using a USB recharging socket, we recommend disconnecting the device, always removing the cable from the vehicle socket first, never from the device. Cables left flying or connected incorrectly could compromise correct recharging and/or the USB socket condition.

## PHONE MODE

### Phone mode activation

To activate Phone mode, register your phone to the system using

### Bluetooth®.

The following options will appear on the display:

- "Browse": to view the list of "Contacts", "Recent Calls" and the graphic keypad on the system display;
- "Settings": this can be used to access the "Settings" menu related to Phone mode, including connecting or registering a new phone.



Turn the BROWSE ENTER button/knob to select the desired option and then press the button/knob to confirm the selection.

### Pairing a mobile phone

The pairing procedure for a mobile phone is described below: always consult the handbook for the mobile phone in any case.

□ Access the "Settings" menu of the Phone;

□ turn the BROWSE ENTER button/knob to select the "Pair new phone" option: a dedicated screen will appear on the display.

The "Settings" Menu can be accessed by selecting the "Settings" button in the "Phone" Menu, or by pressing the "OK" button in the "Phone" Main Menu (when no mobile phone is connected). After selecting it, the "Pair new phone" pairing procedure will start if the vehicle speed is below the maximum permitted threshold.

If the vehicle speed exceeds this threshold, the message "Function not available while vehicle is moving" will appear on the display.

If the pairing process can start when "Pair new phone" is selected pop-up screen indicating the device name and a random 4-digit PIN will appear on the display.

When the vehicle name is selected, and if the 4-digit PIN has been entered correctly in the device, a pop-up message will appear on the display to start the procedure.

The 6-digit confirmation screen automatically replaces the previous one and driver confirmation is required on both the device and the system. Once the PIN has been confirmed, both on the system and the paired device, the pairing procedure will start. If the pairing procedure is successful, the new device is recorded and connected as audio and phone mode.

The driver will be prompted whether to download the phonebook or not. If the connected device has "Siri" or another Voice Assistant function, the corresponding icon will appear on the system display.

NOTE The priority is determined according to the order of connection for mobile phones which are not set as favourite. The first connected phone will have the highest priority and will be the first device displayed on the list.

### Pairing a Bluetooth® audio device

The pairing procedure of an audio device is performed by pressing the  **PHONE** button on the front panel and selecting "Settings". The display will show information (if available) about

the connected device, the pairing was successful.

### Pairing of a Bluetooth® mobile phone

The system connects automatically to the paired mobile phone with the highest priority.

To select a mobile phone or a specific **Bluetooth®** audio device, proceed as follows:

□ access the "Settings" menu of the Phone;

□ turn the BROWSE ENTER button/knob and select the "Connect" option;

□ press the BROWSE/ENTER button/knob to confirm the selection: a dedicated screen will appear on the display.

### Unpairing of a Bluetooth® mobile phone

To disconnect a specific mobile phone or **Bluetooth®** audio device, proceed as follows:

□ access the "Settings" menu of the Phone;

□ turn the BROWSE ENTER button/knob and select the "Delete" option;

□ press the BROWSE/ENTER button/knob to confirm the selection: a dedicated screen will appear on the display.

## Making a phone call

A call can be made by:

- selecting a contact in the phonebook and then selecting "OK" press BROWSE/ENTER key to start the call;
- by dialling a phone number using the graphic keypad on the display and then selecting the "Call" option;
- with the mobile phone and continue using the system (never allow yourself to be distracted while driving). When a phone number is dialled with the keypad of the mobile phone, the audio of the call is played over the sound system of your vehicle.

## Answering a call

To answer the incoming call, press the **PHONE** button on the front panel or  on the steering wheel controls.

## Ending a call

To end a call, press the  button on the front panel or on the steering wheel controls.

## Siri Eyes Free

(available only with iPhone 4S and subsequent versions and compatible iOS versions)

The "Siri" function can be used to use your voice to send text messages, play the content of the device, make phone calls and much more. Siri understands

and replies in natural language and interacts with requests.

Proceed as follows to interact with "Siri":

- pair the "Siri" enabled device with the **UConnect™** system;
- press and release the button  on the steering wheel. When you hear the double beep, the system is ready and you can interact with "Siri" to impart the desired commands.

## Voice assistant

(only available with Android compatible mobile phones)

The "Voice Assistant" function can be used to use your voice to send text messages, play the content of the device, make phone calls and much more. "Voice Assistant" understands and replies in natural language and interacts with requests.

Proceed as follows to interact with Voice Assistant:

- pair the "Voice Assistant" enabled device with the **UConnect™** system;
- press the  button on the steering wheel (long press). When you hear the double beep, the system is ready and you can interact with "Voice Assistant" to impart the desired commands.

## SETTINGS

Press the  button on the front panel to display the "Settings" menu, . The menu includes the following items:

- "Audio"
- "System"
- "Radio"
- "Rear View Camera"

### Audio

The following adjustments can be carried out using the "Audio" menu:

- "Bass";
- "Medium";
- "Treble";
- "Balance";
- "Fade" (only available with rear speakers);
- "Loudness" (where provided);
- "Speed-dependant volume";
- "Volume limits at startup".

### System

The following adjustments can be carried out using the "System" menu:

- "Auto-on"
- "Radio Off Delay"
- "Autoplay"
- "Restore Default"
- "Clear Personal Data"
- "Steering Wheel Seek Buttons"



## REAR CAMERA (Parkview® Rear Back Up Camera)

The vehicle may be equipped with a ParkView® Rear Back Up Camera, which shows an image of the area surrounding the rear of the vehicle on the system display.

The camera images can be viewed in the following cases:

- reverse gear is engaged;
- when the tailgate is opened;
- when the camera is activated manually via the camera menu.

## CONNECTED SERVICES - UCONNECT SERVICES



258)

(where fitted)

Uconnect Services connected services enrich the experience of use of the vehicle by connecting it to the network. The services (where provided) allow you to receive timely assistance in case of need and emergency, to obtain information about the conditions of your vehicle, its location, control it remotely and to improve the navigation experience (where provided) through real-time updates.

You can access the Uconnect Services through the dedicated "FIAT app" for smartphones or smartwatches, a web portal, or the **Uconnect™** system of your vehicle.

The availability of services requires a UConnect Services contract.

**In-Vehicle Activation** is a feature for accessing the activation procedure of connected services directly from the radio by entering your email address. Read more about the Uconnect Services – applicability, availability, compatibility, packages and specifications – on the Fiat Professional website.

### GENERAL DISCLAIMER

#### Personal data & privacy

- The Manufacturer collects, processes and uses the personal data of the vehicle in accordance with legal requirements. Read more about the general conditions of service and data protection policies on the official Fiat Professional website.
- The customer is solely responsible for using the services in the vehicle, even if by other people, and shall inform all users and occupants of the vehicle about the services and the functions and limits of the system.
- If the Help emergency service is activated, the call will be automatically routed to the**

**Manufacturer's private Call Centre. Note that whenever the text refers to the HELP call, it is to be considered managed by private service providers.**

#### Operating prerequisites

- To use some of the Uconnect Services you need to register on the dedicated portal that can be accessed from the Fiat Professional official website, activate and login to your devices.
- Uconnect Services not available in all markets and is subject to limitations depending on **Uconnect™** system type, location and duration of the services.
- The full operation of the Uconnect Services, including Help calls and ASSIST calls, is subject to mobile network and GPS geolocation coverage, without which the proper provision of services is not guaranteed. Coverage may not be guaranteed in places such as tunnels, garages, multi-storey car parks, mountains.
- The services may be unavailable in the event of mobile network overload or problems related to the vehicle power source (e.g. low battery).
- When using the services, customers shall keep their passwords secret for strictly personal use and not to disclose them to third parties.



## SERVICES

**NOTE** The date and time shown on the **Uconnect™** system display must match the actual date and time, even after disconnecting the battery. Adjust it from the "Settings" menu of the **Uconnect™** system. Any discrepancy between the date and time on the display and the actual date and time may be due to a malfunction in the Connected Services.

**WARNING** Some of the services listed below may not be available if the vehicle is left with the motor off for more than 20 days. Start the engine to reactivate these services.

According on the equipment of the vehicle and of the country, different services may be available for different durations. Go to the personal page on the official Fiat Professional website for more information about your vehicle. Some of the packages made available to the customer are:

☐ **My Assistant** (where provided): Customer assistance and safety warning service, which (where provided) includes:

- "Help and ASSIST emergency call" (see "In emergency" section).

- "Vehicle Health Report": information on the status and condition of the vehicle, notifying potential maintenance needs to the customer via "FIAT app" and web. This service is provided on condition that the Customer has previously provided the Stellantis network with a valid e-mail address.

- "In-Vehicle Notifications": possibility to receive messages and/or notifications related to the provision of services and reminder messages about the execution of service and/or recall campaigns on **Uconnect™** system display. You can contact Stellantis Service for further information regarding the messages received.

☐ **My Car**: vehicle status monitoring service: Notification on mobile "FIAT app" of any faults in vehicle operation.

☐ **My Remote**: this can be used to manage remote operations (switching on lights, door lock/unlock, find vehicle, etc.) from the mobile "FIAT app" and through compatible voice assistants. It also allows you to set up Driving Warnings with notifications, for example, when you exceed the set area or time.

☐ **My Navigation**: (subject to availability, according to

version/market): connected navigation service with real-time information on weather, traffic and speed cameras. The service also includes the "Send & Go" function to send the destination from the "FIAT app" to the navigation system of the vehicle and "Last Mile Navigation" to continue navigation from the smartphone if the last stretch of road is not reachable with the vehicle. The Over-The-Air Map Update service allows you to take advantage of the latest version of maps without the need for manual updates.

☐ **My Wi-Fi** (where provided): Optional Wi-Fi Hotspot service. This service provides Internet access from the vehicle to all devices with Wi-Fi connection (smartphones, tablets, laptops) (supported technologies: 3G – 4G). This creates a private Wi-Fi internet access point in the vehicle. The function, available only with the ignition device to MAR or with the engine running allows the connection of up to eight devices simultaneously, but not direct communication between devices. The quality of the service offered by the integrated Wi-Fi Hotspot depends on the coverage of the mobile operator's network.

Users with active data plan with the Wi-Fi Hotspot service can also use the radio- Recognition service on-board



the vehicle to perform operations, such as checking the weather or news, playing music, interacting with the navigation system and remotely controlling intelligent devices in their home.

NOTE: The hotspot name and password can only be changed with the ignition device in MAR position and the engine running.

**My Alert:** optional service with app and notifications via "FIAT app" in case of suspected theft attempts and assistance in case of theft.

You can enrich your Uconnect Services experience by purchasing optional services for which a subscription is required.

The services can be subscribed to independently by the customer from the catalogue of services available for the vehicle, directly on the personal page of the official Fiat Professional website.

## DEACTIVATION OF GEOLOCATION MODE

(where provided)

If you wish to deactivate geolocation mode, simply do so from the **Uconnect™** system (see the "Settings" menu of the **Uconnect™** system for more details).

When geolocation mode is deactivated some of the services on "FIAT app"

or mobile devices and web that use the location of the vehicle will not be available.

**WARNING** The  icon at the top of the **Uconnect™** display indicates that the geolocation function is active (ON). When geolocation is on, the vehicle position is tracked to enable the functions that require it. When geolocation is off, the vehicle position is only tracked by the navigation, safety, insurance and driver assistance systems (where provided). See the **Uconnect™** system "Settings" paragraph to deactivate the function.

**WARNING** If the default settings are restored, turn off the engine (ignition device to STOP) and wait a few minutes before restarting it (ignition device to MAR). The incorrect performance of the operation and the short period of time passed between turning off the engine and turning it back on may cause the Privacy settings to not be maintained. In this case, repeat the operation, extending the wait time between turning off the engine and turning it back on.

## UPDATING THE SYSTEM

Uconnect Services and the **Uconnect™** system application

software are updated remotely in order to provide the customer with newer software versions that include new features or enhancements/enrichments of features already offered.

Updates are made at the manufacturer's discretion. Some system updates will be managed automatically, others will be communicated to the Customer by showing messages on the display of the **Uconnect™**, allowing the customer to confirm or postpone the update itself.

The customer will be notified by the **Uconnect™** system if the system is unavailable.

To read more about services, features, specifications, availability and any updates please always refer to the content included in the official Fiat Professional website.

## DEACTIVATING UCONNECT SERVICES

If you sell your vehicle on which the Uconnect Services are still active, you will be responsible for logging off your profile from the services on the page on the official Fiat Professional website, by contacting the Customer Care or by going to a Fiat Professional Dealership. You will also be responsible for informing the new owner of any

services which have not yet expired associated with a new Uconnect Services account.



### IMPORTANT

**258)** Always follow the highway code of the country in which you are driving, and concentrate on the road. Always drive safely with your hands on the steering wheel. Only use the Uconnect™ system functions when you are sure that it is safe to do so. The customer is liable for all risks associated with using the functions and applications of the vehicle. Failure to follow these rules may cause serious accidents and/or death.

## OFFICIAL TYPE APPROVALS



The radio equipment provided with the vehicle complies with the 2014/53/EU directive, UA.RED.TR, the French SAR Decree Law dated 15/11/2019 and the UKCA (UK Conformity Assessed) Certification in force in the United Kingdom. For more information about certifications and open source lists available for vehicle components use the following link:<http://aftersales.fiat.com/elum/>

## Radio frequency devices



All radio frequency devices comply with the regulations in force in the countries in which they are sold. For more information go to [www.mopar.eu/owner](http://www.mopar.eu/owner) or <http://aftersales.fiat.com/elum>



# BORN TO BE TOGETHER



<sup>®</sup>SELENIA



# SELENIA



## **Oil change? The experts recommend Selenia**

*The engine of your car is factory filled with **Selenia**. This is an engine oil range which satisfies the most advanced international specifications. Its superior characteristics allow **Selenia** to guarantee the highest performance and protection of your engine.*

---

### **The Selenia range includes a number of technologically advanced products:**

#### **Selenia ECO2**

Selenia ECO2 is a synthetic lubricant developed in collaboration with STELLANTIS for passenger car engines that is formulated to have low ash characteristics and provides very high energy saving fluid.

#### **Selenia WR FORWARD 0W-20**

Selenia WR FORWARD 0W-20 is a fully synthetic lubricant developed in collaboration with STELLANTIS specifically designed for latest generation passenger cars with diesel engines (Euro 6 Standards with UREA) and for high-performance engines in the luxury and sport cars segments.

#### **Selenia WR FORWARD 0W-30**

Selenia WR FORWARD 0W-30 is a fully synthetic lubricant developed in collaboration with FCA for Euro 6 diesel engines without urea. Its viscosity grade permits to increase the fuel economy characteristics and consequently the reduction of CO<sub>2</sub> produced.

#### **Selenia DIGITEK PURE ENERGY**

Selenia DIGITEK PURE ENERGY 0W-30 is a fully synthetic lubricant developed in collaboration with STELLANTIS formulated for modern passenger car petrol Euro 6 engines. Its particular viscosity grade and specific formulation are able to increase the fuel economy characteristics and consequently the reduction of CO<sub>2</sub> produced.

#### **Selenia MULTIPOWER GAS**

Selenia MULTIPOWER GAS 5W-40 is a fully synthetic lubricant developed in collaboration with STELLANTIS designed for passenger cars with petrol engines, as well as turbocharged, powered with methane or LPG.

**CHOOSING GENUINE PARTS  
IS THE MOST NATURAL CHOICE**

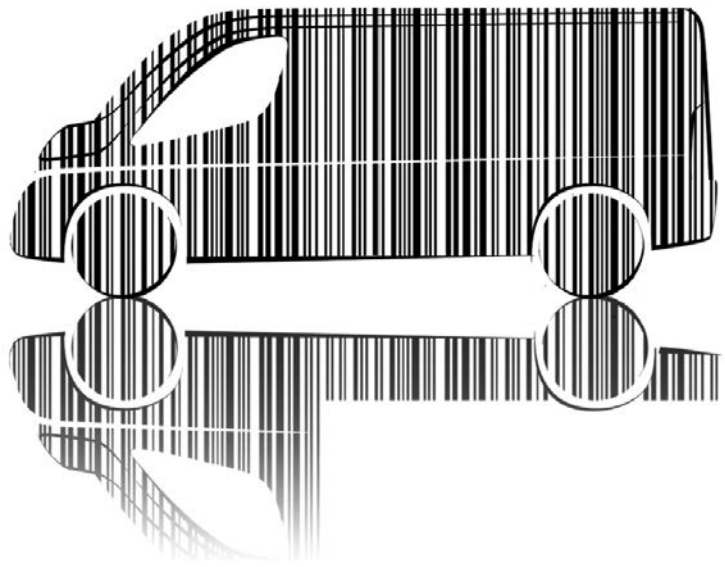

**PERFORMANCE**

**GENUINE PARTS**

**COMFORT**

**GENUINE PARTS**

**SAFETY**

**GENUINE PARTS**

**AMBIENT**

**GENUINE PARTS**

**ACCESSORIES**

**GENUINE PARTS**

**VALUES**

**GENUINE PARTS**



## HOW TO RECOGNISE GENUINE PARTS

All **Genuine Parts** undergo **strict controls**, both during design and manufacturing stages, by specialists using **vanguard materials**, to **test the component reliability**.

This to guarantee **performance** and **safety** for you and your passengers on board, for a long time.

Always ask for and make sure a **Genuine Part** has been used.



## **FLEXCARE - SUBSCRIBE TO PEACE OF MIND**

A collection of extended warranty and service plans (where and which provided) to match the way you drive



### **PROTECTION**

Protect yourself from the unexpected.



### **PREDICTABILITY**

Anticipate the costs, with no surprises.



### **FLEXIBILITY**

Tailor your FlexCare plan to your needs



### **EXPERTISE**

Benefit from Brand Parts and the unique expertise of our network.

The extended warranty, called Extended Care Premium, lets you extend the manufacture warranty beyond its stand duration, allowing you to benefit from the same vehicle protection as the original manufacturer warranty for up to three more years. You can subscribe to an extended warranty contract any time before the original manufacturer's warranty expires.

The Service Plan, on other hand, doesn't just help the maintenance costs of your vehicle, but also gives you valuable additional services to make life with your vehicle easier. There are various levels of service plans available, from basic scheduled servicing operations to more complete packages such as "Complete Care Plus" which combines extended warranty, schedule maintenance, wear items & roadside assistance all in one exclusive plan.

You can discover more and purchase directly on line by visiting the Brand website or speak to your local dealership to see which one is more suitable for your vehicle.







# CONTENTS

|  |     |
|--|-----|
| 4-Seater bench seat (Crew Cab Van versions) . . . . .      | 27  |
| <b>A</b> BS . . . . .                                      | 115 |
| ABS (system) . . . . .                                     | 115 |
| Active ParkSense (Automatic Park Assist) System . . . . .  | 182 |
| Adaptive Cruise Control (ACC) . . . . .                    | 191 |
| AdBlue® (UREA) additive for diesel emissions . . . . .     | 213 |
| Additional heater . . . . .                                | 59  |
| Additional heater fuel cut-off switch . . . . .            | 248 |
| Additional rear climate control (Panorama/Combi) . . . . . | 59  |
| Additional rear heating (Panorama/Combi) . . . . .         | 59  |
| Air diffusers . . . . .                                    | 47  |
| Air filter . . . . .                                       | 262 |
| Ashtray . . . . .  | 70  |
| ASR (system) . . . . .                                     | 116 |
| ASR system . . . . .                                       | 116 |
| ASSIST call . . . . .                                      | 223 |
| Attention Assist system . . . . .                          | 123 |
| Automatic headlight sensor . . . . .                       | 39  |
| Automatic main beam headlights . . . . .                   | 39  |
| Automatic Park Assist . . . . .                            | 182 |

|   |     |
|---|-----|
| Automatic transmission . . . . .                                | 165 |
| Automatic transmission gear lever release . . . . .             | 249 |
| <b>B</b> attery . . . . .                                       | 263 |
| Battery (recharging) . . . . .                                  | 247 |
| Battery disconnection (disconnecter) . . . . .                  | 220 |
| Body paintwork identification plate . . . . .                   | 277 |
| Bodywork . . . . .  |     |
| Advice for preserving the bodywork . . . . .                    | 268 |
| Bodywork version . . . . .                                      | 274 |
| Bonnet . . . . .  | 68  |
| Brake fluid . . . . .   | 258 |
| Brakes . . . . .  |     |
| features . . . . .  | 281 |
| BSA (system) . . . . .  | 120 |
| BSA system . . . . .  | 120 |
| Bump starting . . . . .   | 246 |
| <b>C</b> ab glove compartment . . . . .                         | 70  |
| Capucine . . . . .  | 70  |
| Cargo space . . . . .   | 27  |
| Carrying children safely . . . . .                              |     |
| Arrangement possibilities for child restraint systems . . . . . | 136 |
| Child restraint systems . . . . .                               | 136 |
| Safety regulations . . . . .                                    | 136 |
| Ceiling lights . . . . .  | 43  |

|  |     |
|--|-----|
| Changing a wheel . . . . .                                       | 238 |
| Chassis marking . . . . .  | 277 |
| Checking levels . . . . .  | 258 |
| Cigarette lighter . . . . .                                      | 70  |
| Clutch . . . . .   | 279 |
| CO <sub>2</sub> emissions . . . . .                              | 311 |
| Co-Driver system with Stop&Go . . . . .                          |     |
| Adaptive Cruise Control with Stop&Go . . . . .                   | 198 |
| Traffic Jam Assist . . . . .                                     | 205 |
| Compartment below the passenger seat . . . . .                   | 70  |
| Compatibility of vehicle seats with Isofix child seats . . . . . | 141 |
| Connected Services - Uconnect Services . . . . .                 | 346 |
| Control buttons . . . . .  | 87  |
| Controls . . . . .   |     |
| Summary table of display buttons . . . . .                       | 318 |
| Cross Wind Assist (CWA) system . . . . .                         | 131 |
| Cylinder marking . . . . .                                       | 277 |
| <b>D</b> aytime running lights . . . . .                         | 39  |
| Dead Lock (device) . . . . .                                     | 19  |
| Demanding vehicle use . . . . .                                  | 254 |
| Desk/lectern . . . . .   | 70  |
| Diesel particulate filter (DPF) . . . . .                        | 80  |
| Digital Rear-View Mirror . . . . .                               | 36  |



|   |        |  |     |  |     |
|---|--------|--|-----|--|-----|
| Dimensions . . . . .                              | 290    | Flex Floor rear seat . . . . .                                   | 27  | Hill Descent . . . . .   | 116 |
| Dipped beam headlights . . . . .                  | 39     | Fluids and lubricants . . . . .                                  | 308 | Hill Descent Control System . . . . .  | 116 |
| Direction indicators . . . . .                    | 39     | Follow Me Home (device) . . . . .                                | 39  | Hill Holder (system) . . . . .   | 116 |
| Display . . . . .                                 | 87     | Front airbags . . . . .  | 150 | Hill Holder system . . . . .   | 116 |
| Door pockets . . . . .                            | 70     | Driver's side front airbag . . . . .                             | 150 | <b>I</b> dentification data . . . . .  | 272 |
| Doors . . . . .                                   | 19     | Manually deactivating the front<br>airbag and side bag . . . . . | 150 | Ignition device . . . . .  | 16  |
| Double rear swing door . . . . .                  | 19     | Passenger's front airbag . . . . .                               | 150 | Independent additional heater . . . . .  | 59  |
| Drive Mode (function) . . . . .                   | 170    | Front ceiling light (changing a<br>bulb) . . . . .               | 237 | Inflation pressure . . . . .   | 283 |
| Driving assistance systems . . . . .              | 120    | Front light clusters . . . . .                                   | 232 | Instrument panel . . . . .   | 83  |
| Driving style . . . . .                           | 208    | Fuel consumption . . . . .                                       | 311 | Intelligent Speed Assist . . . . .   | 190 |
| <b>E</b> CO function . . . . .                    | 174    | Fuel cut-off system . . . . .                                    | 249 | Interior . . . . .   | 270 |
| Electric windows . . . . .                        | 68     | Fuel level gauge . . . . .                                       | 83  | Interior fittings . . . . .  | 70  |
| Electronic alarm . . . . .                        | 18     | Fuel tank cap . . . . .  | 210 | Isofix child restraint systems (setup)<br>Arrangement possibilities for<br>child restraint system on seats of<br>vehicle . . . . . | 141 |
| Electronic Cruise Control . . . . .               | 175    | Fuses (replacement) . . . . .                                    | 238 | <b>J</b> ump starting . . . . .  | 246 |
| Engine . . . . .                                  | 277    | <b>G</b> love compartment . . . . .                              | 70  | <b>K</b> eys<br>Electronic key . . . . .   | 12  |
| Engine codes . . . . .                            | 274    | Glove compartment with lock . . . . .                            | 70  | Key with remote control . . . . .  | 12  |
| Engine coolant . . . . .                          | 258    | GSI (Gear Shift Indicator) . . . . .                             | 87  | <b>L</b> ectern . . . . .  | 70  |
| Engine coolant temperature<br>indicator . . . . . | 83     | <b>H</b> azard warning lights . . . . .                          | 223 | Lifting the vehicle . . . . .  | 265 |
| Engine Idle Preset . . . . .                      | 177    | HBA (Hydraulic Brake Assist)<br>system . . . . .                 | 116 | Light bulbs<br>bulb types . . . . .  | 228 |
| Engine oil . . . . .                              | 258    | HBA (system) . . . . .   | 116 | Lights off . . . . .   | 39  |
| EOBD system . . . . .                             | 82     | Head restraints . . . . .  | 70  | Loading advice . . . . .   | 213 |
| EPB (Electric Parking Brake) . . . . .            | 162    | Headlight washers . . . . .                                      | 44  | Luggage carrier . . . . .  | 78  |
| ESC (system) . . . . .                            | 116    | Heating and ventilation . . . . .                                | 48  |  |     |
| External lights . . . . .                         | 39     | Heating and ventilation<br>controls . . . . .                    | 49  |  |     |
| <b>F</b> iat CODE system . . . . .                | 11     | HELP call . . . . .  | 225 |  |     |
| Flap on bench . . . . .                           | 27, 70 |  |     |  |     |
| Flashing the headlights . . . . .                 | 39     |  |     |  |     |

|   |     |   |     |   |         |
|---|-----|---|-----|---|---------|
| <b>M</b> ain beam headlights . . . . .                                  | 39  | Protecting the environment . . . . .                | 80  | SBR (Seat Belt Reminder) system . . . . .         | 133     |
| Main menu . . . . .   | 87  | <b>R</b> ain sensor . . . . .                       | 44  | Seat base plastic covers . . . . .                | 27      |
| Maintenance and care - regular checks . . . . .                         | 254 | Rear bulkhead . . . . .                             | 70  | Seat belts Use . . . . .                          | 132     |
| Maintenance and care - Scheduled Servicing . . . . .                    | 254 | Rear camera (ParkView rear backup camera) . . . . . | 187 | Seat with revolving base . . . . .                | 27      |
| Manual climate control system . . . . .                                 | 51  | Rear ceiling light (changing a bulb) . . . . .      | 237 | Seats . . . . .                                   | 27      |
| Manual transmission . . . . .   | 165 | Rear footboard . . . . .                            | 19  | Seats (Combi versions) . . . . .                  | 27      |
| Manually deactivating the front airbag and side bag . . . . .           | 150 | Rear-view mirrors . . . . .                         | 36  | Seats (Panorama version) . . . . .                | 27      |
| Motor marking . . . . .   | 277 | Refilling . . . . .                                 | 306 | Seats with adjustable armrests . . . . .          | 27      |
| Moving footboard . . . . .  | 19  | Refrigerated compartment . . . . .                  | 70  | Self-levelling air suspension . . . . .           | 77      |
| MSR (system) . . . . .  | 115 | Refuelling the vehicle . . . . .                    | 210 | Service Schedule . . . . .                        | 255     |
| MSR system . . . . .  | 116 | Replacing a bulb . . . . .                          | 228 | Setup for Isofix child restraint system . . . . . | 141     |
| <b>N</b> ozzles . . . . .   | 264 | Replacing an exterior bulb . . . . .                | 232 | Shelf above cab . . . . .                         | 70      |
| Number plate lights . . . . .   | 232 | Dipped beam headlights . . . . .                    | 232 | Side bags . . . . .                               | 150     |
| <b>P</b> arking brake . . . . .   | 160 | Direction indicators . . . . .                      | 232 | Side lights . . . . .                             | 39, 232 |
| Parking lights . . . . .  | 39  | Fog lights . . . . .                                | 232 | Ski rack . . . . .                                | 78      |
| ParkSense (system) . . . . .  | 178 | Main beam headlights . . . . .                      | 232 | Sliding door . . . . .                            | 19      |
| Performance . . . . .   | 300 | Side/tail lights . . . . .                          | 232 | Sliding side window . . . . .                     | 19      |
| Pollen filter . . . . .   | 262 | Replacing interior bulbs . . . . .                  | 237 | Snow chains . . . . .                             | 267     |
| Power socket . . . . .  | 70  | Replacing the windscreen wiper blades . . . . .     | 264 | Snow tyres . . . . .                              | 267     |
| Power steering fluid . . . . .  | 258 | Revolving seat with seat belts . . . . .            | 27  | Spare wheel . . . . .                             | 283     |
| Power supply . . . . .  | 278 | Rim protector . . . . .                             | 283 | Speed block . . . . .                             | 178     |
| Prescriptions for handling the vehicle at the end of its life . . . . . | 312 | Rims and tyres . . . . .                            | 283 | Speed Limiter . . . . .                           | 174     |
| Pre-tensioners . . . . .  | 135 | Rubber hoses . . . . .                              | 270 | Speedometer . . . . .                             | 83      |
| Prolonged vehicle inactivity . . . . .                                  | 220 | <b>S</b> afe Hold . . . . .                         | 162 | Sprung seat . . . . .                             | 27      |
|   |     | Saving fuel . . . . .                               | 208 | Start&Stop system . . . . .                       | 171     |
|   |     |   |     | Starting the engine . . . . .                     | 159     |



|   |     |   |     |
|---|-----|---|-----|
| Starting with auxiliary battery . . . . .               | 246 | <b>U</b> connect Box system battery . . . . .                     | 228 |
| Steering . . . . .                                      | 282 | Uconnect™ . . . . .   | 318 |
| Steering wheel . . . . .                                | 35  | Uconnect™ 5" . . . . .  | 336 |
| Storage compartment . . . . .                           | 70  | Upper storage compartment . . . . .                               | 70  |
| Sun visors . . . . .                                    | 70  | Usage conditions . . . . .  | 208 |
| Supplementary Restraint System (SRS) - AIRBAG . . . . . | 150 | <b>V</b> IN plate . . . . .                                       | 277 |
| Suspension . . . . .                                    | 280 | <b>W</b> arming up the engine just after it has started . . . . . | 159 |
| Switching off the engine . . . . .                      | 159 | Warning lights and messages . . . . .                             | 94  |
| <b>T</b> ablet Holder . . . . .                         | 70  | Weights and loads . . . . .                                       | 303 |
| Tachograph . . . . .                                    | 77  | Wheel geometry . . . . .  | 283 |
| Tachometer . . . . .                                    | 83  | Wheels . . . . .  | 283 |
| Third brake lights . . . . .                            | 232 | Wheels and tyres . . . . .  | 266 |
| Tips, controls and general info . . . . .               | 316 | When parked . . . . .   | 160 |
| Towing a trailer . . . . .                              | 214 | Window washing . . . . .  | 44  |
| Towing the vehicle . . . . .                            | 251 | Windscreen wiper . . . . .  | 264 |
| TPMS . . . . .  | 123 | Windscreen wiper / washer . . . . .                               | 44  |
| Traction Plus system . . . . .                          | 119 | Windscreen/rear window washer fluid . . . . .                     | 258 |
| Traffic Sign Recognition . . . . .                      | 188 |   |     |
| Transmission . . . . .                                  | 279 |   |     |
| Tray under the seat . . . . .                           | 27  |   |     |
| Tyre Repair Kit . . . . .                               | 243 |   |     |
| Tyres . . . . .   | 283 |   |     |

## WHY CHOOSING GENUINE PARTS

We really know your vehicle because we invented, designed and built it: we really know every single detail. At **Fiat Professional Service authorised workshops** you can find technicians directly trained by us, offering quality and professionalism for all service operations. Fiat Professional workshops are always close to you for the regular servicing operations, season checks and practical recommendations by our experts.

**With Fiat Professional Genuine Parts you keep the reliability, comfort and performance features of your new vehicle unchanged in time: that's why you bought it for.**

Always ask for Genuine Parts for the components used on our vehicles; we recommend them because they come from our steady commitment in research and development of highly innovative technologies.

For all these reasons: **rely on Genuine Parts, because they are the only ones designed by Fiat Professional for your vehicle.**

SAFETY: BRAKING  
SYSTEM

ENVIRONMENT: PARTICULATE FILTERS,  
CLIMATE CONTROL SYSTEM MAINTENANCE

COMFORT:  
SUSPENSION AND WINDSCREEN WIPERS

PERFORMANCE:  
SPARK PLUGS, INJECTORS AND  
BATTERIES

LINEACCESSORI:  
ROOF RACK BARS, WHEEL RIMS

The data contained in this publication is intended merely as a guide. FCA Italy S.p.A. reserves the right to modify the models and versions described in this booklet at any time for technical and commercial reasons.

If you have any further questions please consult your FIAT dealer.

Printed in recycled paper without chlorine.